



Audiovisual Improvements Feasibility Study Report



City of Cambridge, MA
August 2013

TABLE OF CONTENTS

I. EXECUTIVE SUMMARY 1

II. PROJECT SCOPE

- a. Setting and Ranking of Priorities 2
- b. Existing Conditions: Common Problems & Shared Solutions 2
- c. Interventions: Study Approach & Content 2
 - Intervention No. 1: Sullivan Chamber 5
 - Intervention No. 2: Ackermann Room 19
 - Intervention No. 3: Sophie Anastos Room 27
 - Intervention No. 4: Senior Center 33
 - Intervention No. 5: City Hall Annex 43
 - Intervention No. 6: Waterworks 49
 - Intervention No. 7: Lombardi Room 55
 - Intervention No. 8: Portable A/V System 61

III. IMPLEMENTATION & PHASING

- a. Implementation Strategy 65
- b. Phasing Recommendations & Estimated Costs 66
- c. Phasing Schedule 66

APPENDIX A: REFERENCE DOCUMENTS

- a. Full Cost Estimate (VJ Associates)
- b. Audiovisual System Design (Acentech)
- c. Acoustics & Mechanical System Noise & Vibration Control (Acentech)
- d. HVAC Assessment Recommendations (BER Engineering)
- e. Lighting Assessment Recommendations (Lam Partners)
- f. Hazardous Material Survey (Fuss & O’Neill Enviroscience)

APPENDIX B: LIST OF STUDY PARTICIPANTS

APPENDIX C: PROCESS DOCUMENTS

- a. Architectural Scope Matrix
- b. Accessibility Project - Annotated Drawings
- c. User Questionnaire & Responses

I. EXECUTIVE SUMMARY

INTRODUCTION

The recommendations contained in this report will provide a framework for the execution of numerous improvements in the function and presentation capability of important civic spaces for the City of Cambridge. Public engagement in City policy and operations is critical to civic dialogue and the health of the relationship between constituents and City government. The spaces addressed in the feasibility study are some of many where this dialogue takes place. Smooth operation, clear reproduction of sound and video, ease of use, flexibility and a consistent, intuitive user interface are imperative for AV systems in all of these spaces. The study team's goal was to provide the City with proposed guidelines, product and system recommendations, systems renovations and an implementation strategy to realize these goals.

The design team was directed to assess two historic spaces in City Hall, the Sullivan Chamber and Ackermann meeting room. Also examined were the Sophie J. Anastos Room, Senior Center Ballroom, the City Hall Annex Community Room and the development of a portable AV system to provide even greater flexibility for presentations and public meetings. The original study scope was expanded in February of 2013 to include the lobby of the Cambridge Water Department at 250 Fresh Pond Parkway and the Lombardi Room at 831 Massachusetts Ave. The study encompasses a broad range of spaces, each with their own challenges and opportunities. In each case, the design team worked to refine an approach that balanced the City's goals, estimated construction cost and ease of implementation while minimizing the disruption of day-to-day City operations.

This study will address in detail the challenges presented by existing conditions in each space and provide a set of actionable recommendations to improve AV systems, room acoustics, lighting conditions, mechanical systems and overall functionality in each space. These recommendations have been informed by extensive dialogue with City leadership, a survey of City employees, multiple field visits to each space and consultation with Charles Sullivan of the Cambridge Historical Commission. This document is intended to be used in support of the development of full bid documents for some or all of the recommended interventions and their execution over the next several years.

General Note Regarding Cost Estimates

It is important to note that the costs referenced in this report and described in Appendix A are subject to changing bid environments, material market costs and unforeseen conditions that may be discovered in the course of construction. Additionally, the estimates included in this report do not cover all enabling or collateral projects that could result from work on the spaces that have been studied. This could include repairs and commissioning of existing systems, relocation costs or outside project area infrastructure improvements.

II. PROJECT SCOPE

A. SETTING & RANKING OF PRIORITIES

Given the fiscal challenges that every municipality must face, the design team and the City met and revised the project approach after a review of initial cost estimates. LDa worked with the City to assign different priority levels for each space and develop an implementation strategy to give the City maximum flexibility in executing the work with respect to budget and schedule, as well as a high level of control of the A/V installation and servicing. High profile spaces such as the Sullivan Chamber and those with very heavy use such as the Senior Center were given top priority status.

B. EXISTING CONDITIONS: COMMON PROBLEMS & SHARED SOLUTIONS

The team encountered similar issues in many spaces during our investigation. HVAC-related acoustic problems had numerous sources: poor installation, outdated equipment, maintenance issues, machine noise, inappropriate duct/diffuser sizing, and distribution design. Every room studied stands to benefit significantly from improved lighting, particularly the Sullivan Chamber and Senior Center Ballroom. In most rooms, the existing acoustic ceiling material is damaged and not performing well. Video presentation capability, controls and speech reinforcement systems were typically in need of retooling. The audiovisual systems recommended in this report can all be installed with a minimum of disturbance to existing architecture while transforming the quality of presentation, controls and speech reinforcement in a given space.

C. INTERVENTIONS: STUDY APPROACH & CONTENT

The design team has formulated this portion of the report to identify each room's proposed improvements as a discrete project for the City to evaluate. These discrete projects may be executed in any combination or sequence that proves advantageous to the City. We have highlighted considerations we believe are important in Part III of this document (Implementation & Phasing).

The discussion portion of each section is a synthesis & summary of the more detailed information contained in each consultant's report. Language in these sections is occasionally taken directly from the documents in Appendix A. Images provided in the body of this report range from existing conditions photos, historic photographs, proposed equipment and equipment locations and schematic diagrams of mechanical systems to plan diagrams and ceiling plans. There may also be instances where the summary portion and the Appendix differ slightly. This is due to either direct input from the City or a refinement of the consultant's recommendation by LDa in the preparation of this report.













READING THIS REPORT: SYMBOLS, SHORTHAND & REFERENCES

Each section of Part II provides a synopsis of a particular space, its needs and our recommendations. There is a brief overview, a summary of existing conditions and five analytical categories that compose the discussion of each space: Audio/Visual, Acoustics, Lighting, Mechanical and Architecture. Categories may vary slightly depending on the scope of work for a given space. The work associated with each category is synthesized from the consultant reports in Appendix A, user input, core committee discussions and additional considerations based on LDa’s experience with similar projects. This detailed description of proposed interventions is followed by a brief implementation and phasing priority summary as well as the estimated cost of the proposed scope. Each section ends with a Z-folded drawing of the space. The report is designed for the reader to open this drawing and use it as a companion reference as they read about each intervention. The plan drawing is populated with icons that indicate the scope for each space and the proposed location of new audiovisual technology, controls and casework.

TYPICAL ABBREVIATIONS

AV	Audiovisual
AFF	Above Finish Floor
CFL	Compact Fluorescent Lamp
cfm	Cubic Feet per Minute
fc	Footcandle
GWB	Gypsum Wall Board
HVAC	Heating, Ventilation & Air Conditioning
LED	Light Emitting Diode
NRC	Noise Reduction Coefficient
RT60	Reverberation Time (for 60dB decay)
STC	Sound Transmission Coefficient
VAV	Variable Air Volume

TYPICAL PLAN ICONS

	Projection Screen
	Projector
	Loudspeaker
	Video Camera
	Control Location
	Assistive Listening System
	Floor Box
	Monitor
	Flip-up grommet
	Radiant heating
	Split system unit
	North arrow



INTERVENTION NO. 1: THE SULLIVAN CHAMBER

INTERVENTION NO. 1: SULLIVAN CHAMBER

Overview

The Sullivan Chamber one of the most important civic spaces in the City of Cambridge. A strong desire to keep the room historically “intact” has resulted in a strategy, informed by input from Charles Sullivan of the Cambridge Historical Commission, where new technology is “applied” to the space rather than fully integrated architecturally. This approach maintains the integrity of the space while allowing flexibility in the future to retool systems with the next generation of equipment or integrate proposed equipment more fully (such as recessing loudspeakers into the wall). The room has a number areas that need attention for maintenance reasons, but were not considered comprehensively as a part of this study. The proposed intervention requires careful coordination with the schematic design of a proposed accessibility upgrade. The focus of the recommended work is to improve speech reinforcement, provide video presentation and playback capability, improve overall acoustic performance and overall lighting conditions. A significant portion of new equipment will address outdated and under performing equipment used by the Office of Cable Television (Cable TV) to record and broadcast public hearings as well as the option to provide video streaming capabilities that were previously non-existent.

Observations & Existing Conditions

The Sullivan Chamber is currently heated only. The primary heating system is composed of radiators lining the East window wall. Two fan-forced electric coil heaters, located behind a grille on the room’s West wall, are utilized for extremely cold days and produce an unacceptable level of noise during operation. Four ceiling mounted fans, used to de-stratify air in the room, also add to the noise level in the room.

Two major renovations of the Sullivan Chamber resulted in significant changes to the “historic” (Fig. 101 & Fig. 102) lighting design. Measured lighting levels average 5fc at 30” AFF, inadequate for most activities and programming expected in the space. Existing wall mounted floodlights used for broadcasting purposes generate uncomfortable glare and are not in keeping with the historic interior aesthetically.

The existing speech reinforcement system uses four large loudspeakers in the corners of the room (Fig. 103). The speakers are poorly located and lack directional control, resulting in an excessively reverberant sound quality. No speakers serve the mezzanine area (Gallery). The direct-applied acoustic tiles that cover both the ceiling coffers (Fig. 101) and the curved areas of the ceiling perimeter have been painted over the years (Fig. 104), hampering their performance significantly. Measured reverberation time in the space yielded an RT60 of 1 second, longer than desired given the Chamber’s program. The study team noted numerous complaints from users about noise build up in the chamber as well as poor speech intelligibility.

Four remotely controlled, pan/tilt mounted video cameras (Fig. 105) serve the space and provide signals for the Cable TV’s video production needs. These existing “box” cameras are visually bulky and are only able to provide analog video signals, a format that has become obsolete with the changeover to digital television broadcast technology. The cameras are operated from the Control Room (located on the mezzanine), where video signals are processed and edited on similarly outdated analog video production equipment. There is no video presentation system in the Sullivan Chamber.



Fig. 101 - Sullivan Chamber in 1891



Fig. 102 - Sullivan Chamber in 1967



Fig. 103 - Existing Loudspeaker



Fig. 104 - Existing Acoustic Tile



Fig. 105 - Existing Video Camera

Audio/Visual

- New column loudspeaker system (pair)
- New digital video cameras, digital projector & projection screen
- 2 Dais monitors (Gallery Monitors & loudspeakers -optional)
- 3 wireless microphones & Assistive listening system
- New document camera & source equipment on a castered rack
- Neutral density filters on windows

Video

A electric roll-down, 10' wide projection screen (Fig. 111) will be mounted on the wall behind the Chamber dias and receive images from a high-brightness digital projector (Fig. 106 & Fig. 110) mounted on the South wall. The video display, visible to all on the chamber floor, will be mirrored on 17" monitors located on the dias (Fig. 111). This will allow City administrators at the dias to view video presentations without having to turn 180 degrees to see the projected image. These monitors could be flat-mounted or housed in an integrated motorized lift that conceals below the work top when not in use. If the City deems it necessary, a pair of 60" LCD flat panel displays (Fig. 107, Fig. 116) can be located in the Gallery above the openings to the Chamber to mirror any video presentation as well as video feeds from the wall-mounted digital video cameras. It is the team's understanding that the gallery monitors would be a low priority given the infrequent use of the Gallery seating.

At the request of the City, an additional 17" LCD display will be provided on a rolling cart that can plug into a receptacle at the back of the room to mirror the larger projected image. This request was due to concerns that people in the very back of the room would not be able to see the image on the large projection screen. Acentech believes that the redundant display will not be necessary and proposes the provision of a single display that can be used either in the Sullivan Chamber or the Senior Center (where a similar display has been requested). If it does prove necessary, a second such display can be procured following completion of the installation.

Loudspeakers, Speech Reinforcement & Assistive Listening

A new steerable column loudspeaker system (Fig. 108 & Fig. 111), consisting of two speakers flanking the dias, will replace the existing four loudspeakers in the Chamber's corners (Fig. 103). In contrast to the existing equipment, the new speaker system will direct sound at the listeners and not the ceiling and walls of the room, where the resulting sound reflections would reduce intelligibility. Several small loudspeakers will be provided at flat panel locations in the gallery as well.

Participants at the dias, councilors and other fixed locations will use existing wired microphones unless design decisions dictate their replacement. Three wireless microphone systems (Fig. 109) will be provided for a presenter who wishes to move around in the room, for audience members at the rear of the room and for audience members in the gallery. Existing floor boxes will be used for microphone connections at councilor desks or at the conference table. A digital audio signal processor will provide mixing and processing, functionality to mute unused microphones and support for audio conferencing if an individual needs to participate by phone. A wireless assistive listening system is provided as well, as required by the Americans with Disabilities Act. Portable receivers can be stored in the castered rack and handed out to participants as needed.



Fig. 106 - Digital video projector



Fig. 107 - 60" Flat panel display



Fig. 108 - Column loudspeaker



Fig. 109 - Wireless microphone system



Fig. 110 - Diagram of rear chamber wall with new wall mounted projector (existing clock shown lowered)



Fig. 111 - Diagram of dias wall view with new projection screen, column loudspeakers & dias monitors

Source Equipment

New source equipment will be located in a castered equipment rack with a work top that can be plugged in to receptacles in the existing chamber floor box and positioned wherever the presenter desires. The rack will be outfitted with a high resolution document camera for the display of printed material, drawings or small objects (Fig. 112). Digital and analog connections for laptop computers, portable audio equipment, portable video equipment and a Blu-ray DVD player will be provided in the rack as well. A computer, mouse and keyboard will be provided by the City. Television programming will be provided by tuners located in the central control room. A wireless presentation device will provide even more flexibility, allowing devices to be connected for presentation independently from the equipment rack.

Control Locations

A color LCD touch screen will be provided at the dias and at the castered equipment rack (Fig 114). Each module will have the capability to control the following:

- Lighting scenes, as defined by the Grafik Eye system (see LIGHTING below)
- DVD playback functions
- Video capture
- Video and Audio source selection
- Audio volume levels

The interface for the touchscreen control modules will be consistent through all interventions, with those in the Sullivan Chamber having the greatest variety of functions.

Video Production

Video production efforts will be supported by four high-definition pan/tilt cameras at existing camera locations (Fig. 115). A fifth camera, adjacent to the rear camera, will give operators a constant overall shot of the chamber. The existing VHS and DVCAM recorders will be retained in the control room for standard definition recording, while a character generator, production switcher, pan/tilt controllers, camera/production preview and program monitors will be provided. If high definition format recording is desired, a Panasonic p2 format recorder will be provided. The option exists for Rich Media recording for streaming purposes, enabling both video of an event and a “snapshot” of presentation media to be captured. Recording of events for live or delayed streaming will be executed by the video production system. Delayed streaming will require a server provided on the City network for storage of the content and administration of the streaming function.

The City expressed interest in shifting the procurement of the recommended television production equipment to the Office of Cable Television. It is the study team’s recommendation that at the very least, all new audiovisual equipment associated with the Sullivan Chamber be installed, commissioned and configured by the same contractor. Additionally, the light control requirements for video production should be studied. This intervention provides film-type neutral density filters for the chamber windows, but they still may provide an unacceptable level of glare (Fig. 117 & Fig. 118) and require more significant measures.



Fig. 112 - Document camera



Fig. 113 - Wireless presentation device



Fig. 114 - Touchscreen control panel



Fig. 115 - HD pan/tilt video camera

Acoustics

- Remove all existing acoustic tile
- New acoustic panels in coffers
- Fabric wrapped acoustic paneling panel at sloping ceiling
- New acoustic panels in Gallery (optional)
- Acoustic window treatments (optional)

A reverberation time (RT60) of .7 seconds or less is recommended for the Sullivan Chamber to mitigate excessive and delayed reflections from sound reflective surfaces (hardwood furniture, plaster surfaces, wood wainscot, hardwood flooring at the dias) in the room. To achieve this level of acoustic performance, all acoustic ceiling treatments in the room should be replaced with a product that provides an NRC of 0.70 when direct-applied. Fabric wrapped panels are recommended for both coffers and the sloped ceiling areas. Replacement of existing acoustic finishes will improve room performance considerably, but it is likely that noise build up will still be an issue for particularly animated meetings. The City may elect to add absorptive fabric window treatments, acoustic panels on the Gallery ceiling coffer (Fig. 116) and/or acoustic wall panels in the mezzanine as a method to reduce reverberation time further.

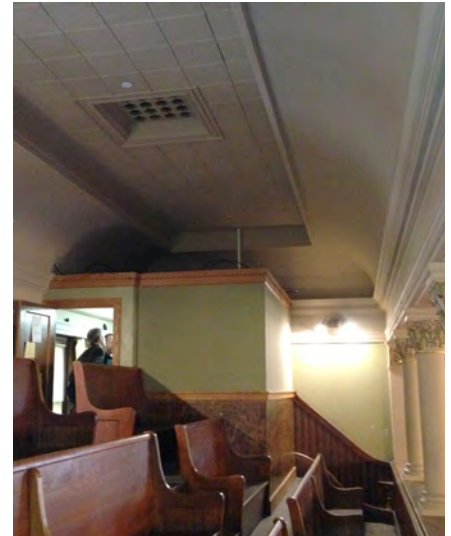


Fig. 116 - Gallery ceiling coffer



Fig. 117 - New acoustic panel locations



Fig. 118 - Glare from existing windows

Lighting

- New lamping for existing fixtures (pendants & sconces)
- New rear-relampable LED down lights in ceiling coffers
- New linear LED perimeter cove uplighting
- LED task lighting at councilor desks
- Lutron Grafik Eye scene preset dimming system
- Two additional remote 4-button control system
- Remove existing spotlights

To address general lighting conditions in the Sullivan Chamber appropriately, it is recommended that the design target an ambient lighting level between 20 and 40 fc at 30" AFF. Rear-relampable fixtures are suggested for the new ceiling coffer luminaires due to the significant height of the space and the presence of an accessible attic. The recommended LED lamps will have outstanding service life and can be serviced or aimed easily without introducing maintenance staging to the chamber. The coffer mounted luminaires can be adjusted to target speakers and desks or to wash the walls of the room.

A new linear LED cove fixture will wash the ceilings at the perimeter of the room, improving the perceived brightness of the space while providing soft, shadowless illumination for various tasks (Fig. 119 & Fig. 124). The majority of the light from this luminaire will be reflected off the new acoustic panels. LED task lights (Fig. 120) are recommended at councilor desks to minimize modifications of existing furniture and provide illumination for reading or note taking while the room is darkened for presentations.

A 12-zone lighting control system will enable to the setting of a broad range of specific lighting "scenes" for regular events in the space. Once programmed, these scenes will be available at the touch of a button, ensuring a consistent and appropriate lighting level for all areas of the room. These remote 4-button controllers will be located at both entrances to the chamber for easy access from the dias or the rear of the chamber.

Existing sconces (Fig. 110) will be relamped with LED lamps and have their shades replaced. The new luminaires in the ceiling will meet general illumination needs, so, if desirable, consideration should be given to removing the four pendants added in 1967 (Fig. 102) and returning to the earlier single chandelier design and "flower" sconces circa 1891 (Fig. 101).



Fig. 119 - Linear LED Cove Light



Fig. 120 - LED Task Light



Fig. 121 - Grafik Eye dimming system & 4-button lighting preset control panels

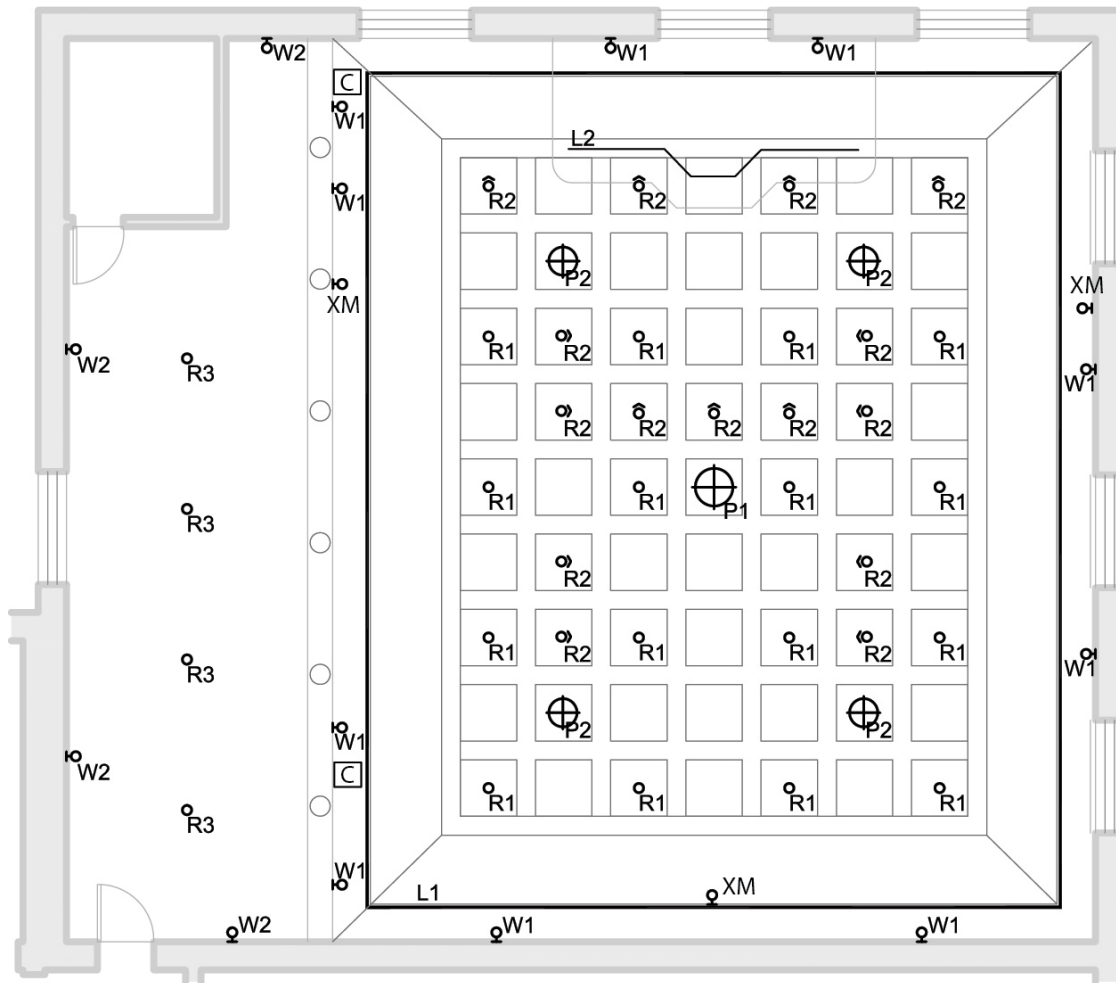


Fig. 122 - Reflected Ceiling Plan & Legend (Lam Partners)

- L1 Continuous LED uplight integrated above existing cornice
- P1 Relamp existing pendant with new LED lamps
- P2 Relamp existing pendant with new LED lamps
- W1 Relamp existing wall sconces with new LED lamps

- R1 New recessed LED downlight
- R2 New recessed LED adjustable accent light
- R3 New recessed LED downlight
- C New dimming control (2 locations on Chamber floor)



Fig. 123 - Existing conditions lighting
(digital model - Lam Partners)



Fig. 124 - Proposed lighting model
(digital model - Lam Partners)

Mechanical

- Electric fan coil demolished
- New perimeter heating system
- New quieter fans possible
- Cooling for audiovisual/Cable TV control room

The proposed accessibility project will require replacement of the existing cast iron radiators. The electric fan coil heaters, existing radiators and associated piping should be removed (Fig. 126). By replacing these older radiators (Fig. 128) with new, more efficient Runtal RS-2 convectors (Fig. 127), the re-sized perimeter system can meet the Chamber's heating needs on its own. The existing ceiling fans perform an important role by mixing air in the space, but could be replaced with quieter models if desired. The design of the new heating system must be coordinated with the planned accessibility project to eliminate conflicts and ensure proper performance. Because the Sullivan Chamber has no system to provide ventilation air, any acoustic gasketing or automatic door bottoms added to entry doors should be vetted by the mechanical engineer. A split system is recommended to provide colling for the Control Room.

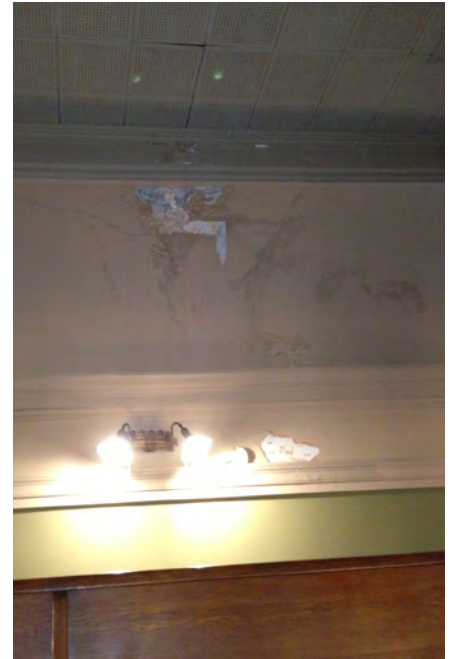


Fig. 125 - Water damage - Gallery ceiling



Fig. 126 - Existing electric heaters behind metal grille



Fig. 127 - Proposed Runtal RS-2 Radiators



Fig. 128 - Existing radiators

Architecture

In general, the architectural approach for the Sullivan Chamber is to avoid permanent aesthetic changes to the historic interior. For this reason, replacement equipment will use existing mounting locations and new equipment will be surface mounted on existing finishes. Some alterations will be necessary to accommodate new equipment and ensure smooth operation. The clock at the rear of the room will likely need to shift to a lower position (Fig. 110) to allow mounting of the new video projection system and the projection screen will need to be held off the dias wall to prevent contact with existing portraits and sconces. The team noted that the position of some current elements in the room (such as the sconces behind the dias) defy the very strong symmetry of the room. Consideration should be given to realigning the sconces on the dias wall, as they are currently off center and will only appear more so after the installation of the column loudspeaker system and projection screen.

The new perimeter heating system, like any new piece of equipment in the Sullivan Chamber, must be coordinated with the existing wood paneling and windows. The Runtal units are sized in 2" increments, making them flexible and ideal for integration in historic spaces. The design of the new disabled ramp system must allow air to pass below it and over the wall convectors. This can be accomplished by holding the ramp off of the West wall by 4-6 inches and perforating the East sidewall of the ramp. The location of the electric heaters is to be closed with a finish-painted panel placed behind the existing grille after the equipment is removed.

The proposed accessibility project should be reviewed with respect to its impact on the East councilor desks, overall room symmetry, floor box locations and for further development to coordinate with the new heating system proposed in this study. Drawings of the accessibility project have been annotated and are included in Appendix C. The City directed the study team to remove the absorptive window treatments from our recommendations for both cost and maintenance reasons. If the acoustic measures outlined in this report prove insufficient after installation, exploring the approach described in Appendix A would be a prudent next step.

The issue of light control is critical for video production. Discussion throughout the study process ranged from motorized shades to full height velour curtains for the window wall. The recommended intermediate step is to provide neutral density filter film on the Chamber windows. This will greatly reduce glare and give the City the opportunity to evaluate conditions before taking more expensive measures.

Final design documents should address any additional blocking and structural support required for the proposed new equipment. The finish color of any equipment that will be visible must be reviewed during the submittal process and consideration should be given to a custom color finish for prominent elements being added to the chamber, such as the video projector and column loudspeakers. The execution of this significant intervention is an opportunity to renovate known damaged areas (eg. water damage in the mezzanine ceiling, Fig. 125) and will likely lead to the discovery of more areas in need of minor repair.

Phasing Priority: 1

Typical Chamber Configurations

The Sullivan Chamber, by necessity, must be able to accommodate a wide variety of events. The design team is confident that the castered equipment rack, new wireless capabilities, new control systems and retooled floor boxes at existing locations will meet the City's needs for all typical seating/presentation arrangements. The City should review these requirements during design development and prior to the issuance of final design documents to ensure that any new needs are met. Additional consideration should be given to the accessibility project's impact on the councilor desk locations and associated floor boxes. Annotated drawings of the proposed accessibility project are included in Appendix C.

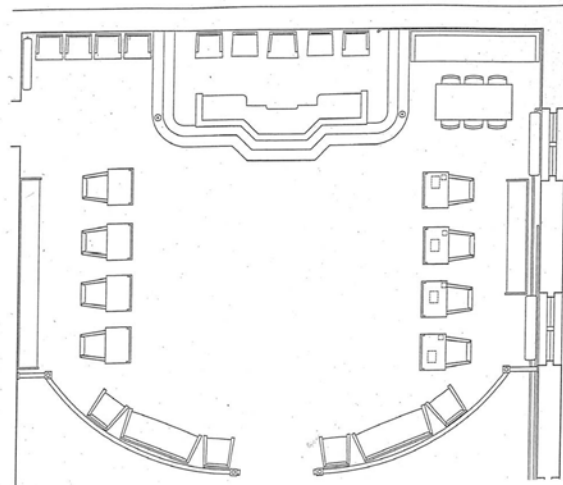


Fig. 129 - Employee awards

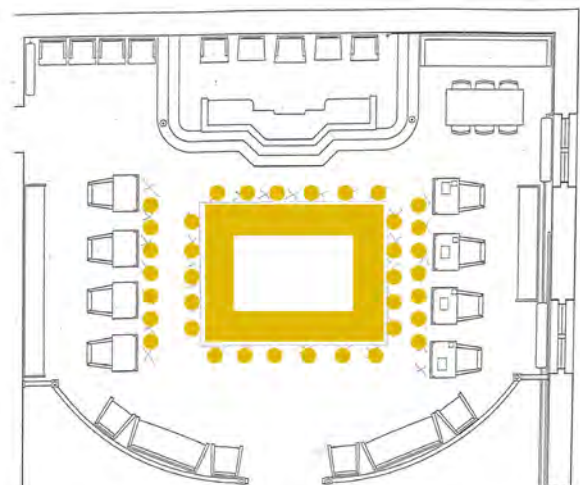


Fig. 130 - Roundtable

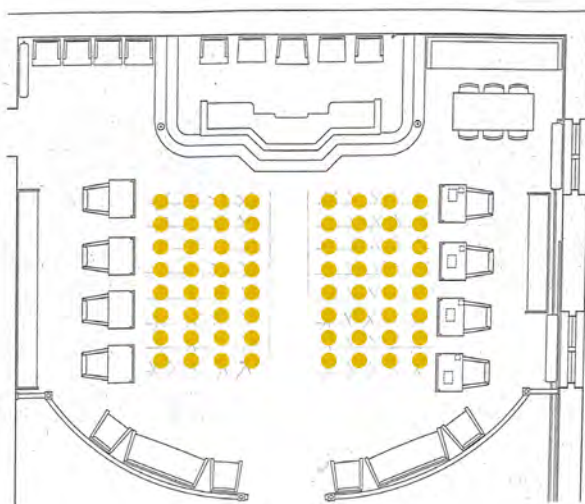


Fig. 131 - Special events

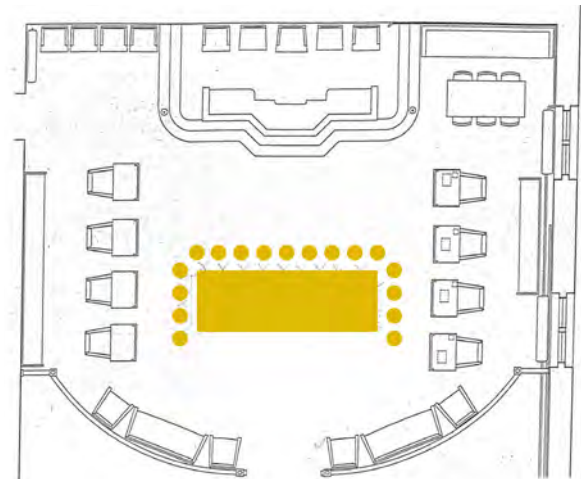


Fig. 132 - Meeting/presentation

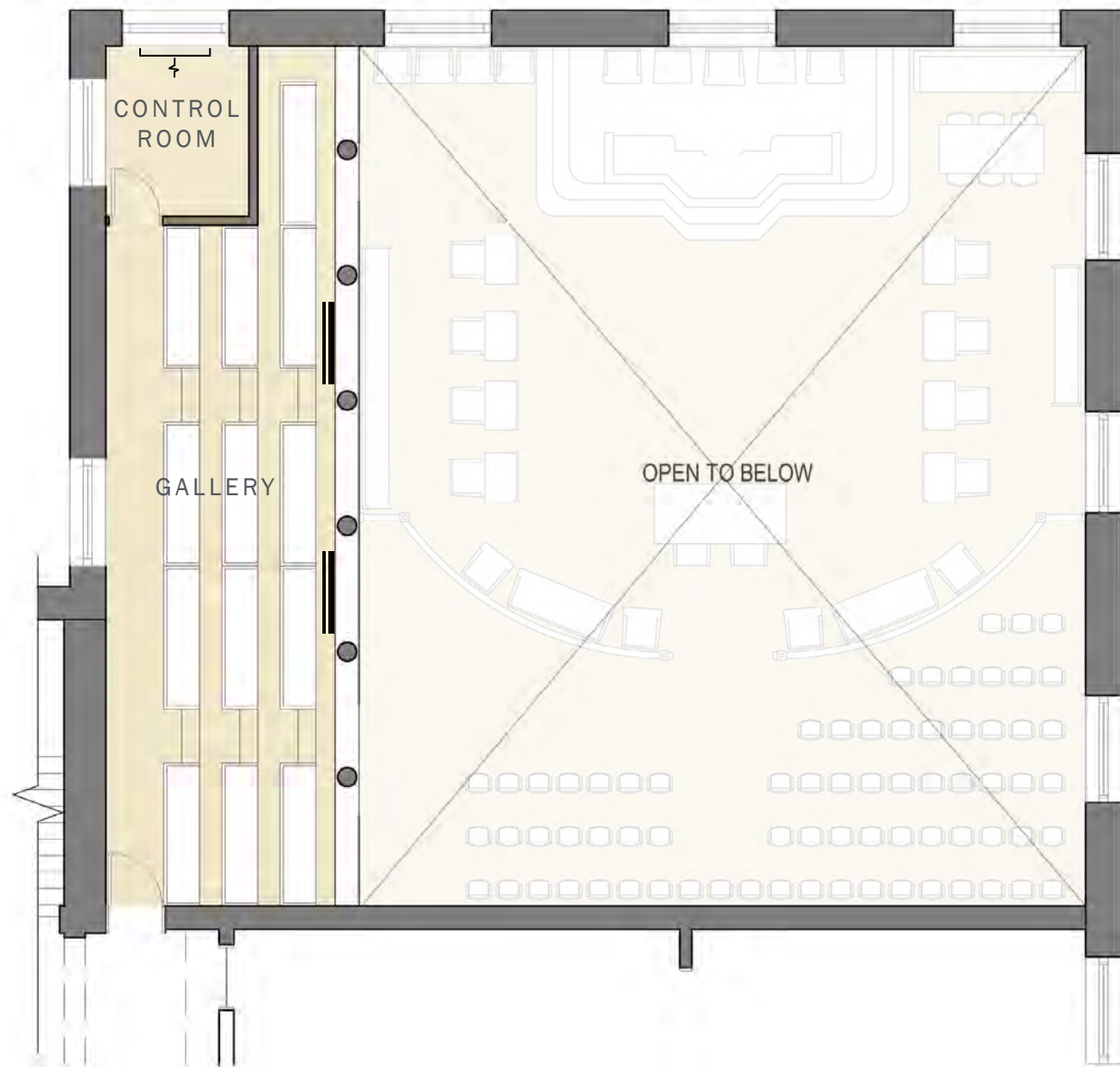


Fig. 133 - Proposed Mezzanine/Gallery Plan Diagram

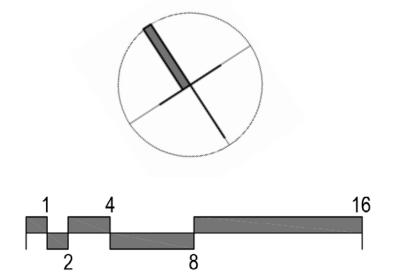
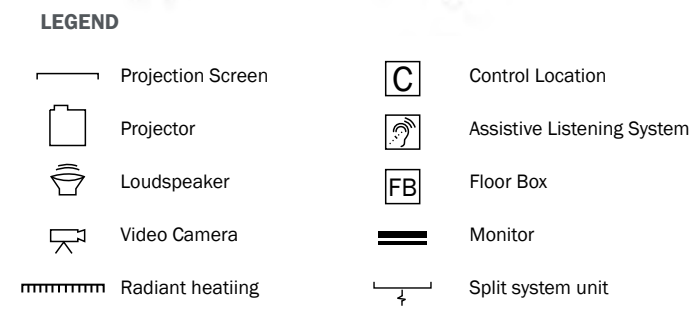
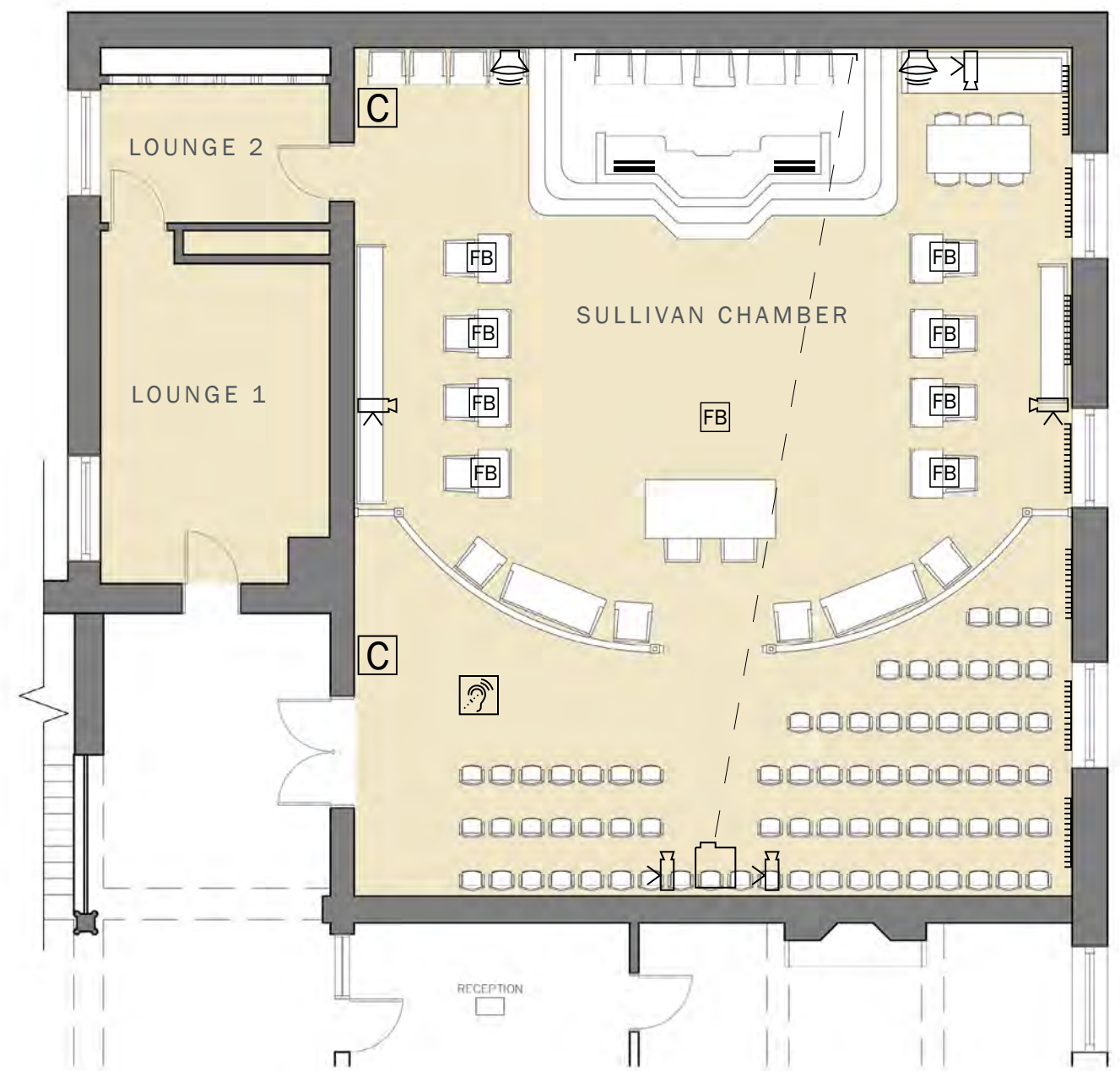


Fig. 134 - Proposed Sullivan Chamber Plan Diagram



INTERVENTION NO. 2: ACKERMANN ROOM

INTERVENTION NO. 2: ACKERMANN ROOM

Overview

The Ackermann Room is public meeting room located in City Hall. The room is richly detailed in wood paneling, decorated with portraits of civic leaders and has a single, large conference table located on the south side. The other half of the room is often filled with temporary seating to accommodate a variety of meeting types. A second entry to the room, on the East side, connects to adjacent administrative spaces and has been blocked off in a previous renovation. The primary goal for this project in this space is to integrate appropriate media technologies and improve lighting conditions while preserving the historic character of the room.

Observations & Existing Conditions

Though the room is proportioned well for a variety of meeting types, there is no audiovisual presentation system present. Manual window shades provide adequate daylight control but existing track lighting is insufficient for reading at the conference table, and has a poor layout and controls. The existing pendant lights are inefficient and the dark finishes throughout the room worsen the poor lighting conditions. There is staining on the existing ceiling tile and the current track lighting is poorly configured for the room. Heating and cooling provisions are adequate, with a single ductless split system unit is located on the north wall of the room. Existing ceiling fans are relatively quiet, measured at NC25.



Fig. 201 - North Wall



Fig. 202 - East Wall



Fig. 203 - South Wall



Fig. 204 - West Wall



Fig 205 - Existing split system unit



Fig. 206 - Existing ceiling fan, pendant & track lighting (note damaged acoustic tile)

Audio/Visual

- 70" Flat Panel Display
- Video conferencing capability
- Integral power/data connections at conference table
- Loudspeaker system
- Portable assistive listening connection
- A/V control module for video/audio/lighting
- Conference telephone

The addition of a substantial flat panel display, videoconferencing capability, a speaker system and integrated controls will make the Ackermann Room extremely desirable as a meeting space. The videoconferencing camera and loudspeakers will be located at the flat panel display on the room's West wall. Source equipment, the control module and videoconferencing codec (Fig. 207) will be located in custom millwork designed into the abandoned entry, also on the West wall. Limited data and power connections will be replaced by flip-up type data/power grommets (Fig. 208) integrated in the existing conference table. These elements have been selected and located to provide maximum functionality with minimal disruption of the room's original millwork. If desirable, the City should consider locating the required loudspeakers in the room ceiling.

Acoustics

- New surface-applied acoustic ceiling treatment
- Sound isolation measures at entry door

Significant noise is produced by the existing split system. With the unit on, the background sound level in the room was measured at NC40; off, the reading drops to NC20, an preferable level for the desired uses of the Ackermann Room. The split system should be replaced with a new, quieter unit and should have its fan setting at "quiet" or "low" during videoconferencing. Room acoustics will be improved when the existing acoustic ceiling panels, which have been painted over and suffered water damage (Fig. 206) in some locations, are replaced with new panels with a rating of NRC 70. If work requires the carpet to be removed, the floor should be refinished with carpet to maintain acoustic performance.

The Ackermann Room is adjacent to the heavy foot traffic and activity of City Hall's main stair hall, finished with a terrazzo floor and lacking any acoustic absorption. To isolate any meeting activity from this noisy area, the entry door for the Ackermann Room should be provided with a perimeter gasket, automatic door bottom and threshold. Any modifications to the door should be vetted with the project mechanical engineer, as the room relies on the entry door undercut for fresh air.



Fig. 207 - Videoconferencing codec & camera



Fig. 208 - Flip up grommets (open & closed)



Fig. 209 - Control module

Lighting

- New track lighting & layout
- New lighting control module
- Relamping of existing pendants

The recommended approach to improve lighting in the Ackermann Room is comprehensive and will transform the space. New track lighting will wrap the room’s perimeter, showcasing the wood paneling and portraits while giving the room a much brighter, warmer feel. New, higher wattage “silver bowl” lamps will be provided for the existing pendant fixtures and will provide much improved general lighting throughout the room. Careful coordination with the AV systems provider will be imperative to ensure that no glare is introduced to the flat panel display in videoconferencing applications. All new lighting and existing lighting to remain will be dimmable and controlled through a Grafik Eye dimming system or through individual wall box dimmers if preset scenes are not required.

Mechanical

- Replacement & relocation of existing split system
- Existing fans to remain

The existing split system unit should be replaced with a new, quieter wall unit to be located to the North wall of the room, at or near the entry. This will keep a potential source of undesired noise on the opposite side of the room from the conference table. Another option is to provide a ducted unit outside the room and deliver cool air through a wall mounted diffuser. The ducted option is more costly, but offers a better aesthetic result. Regardless of the unit type that is selected, the power feed to the unit will need to be relocated and the unit’s final location should be confirmed with the architect.

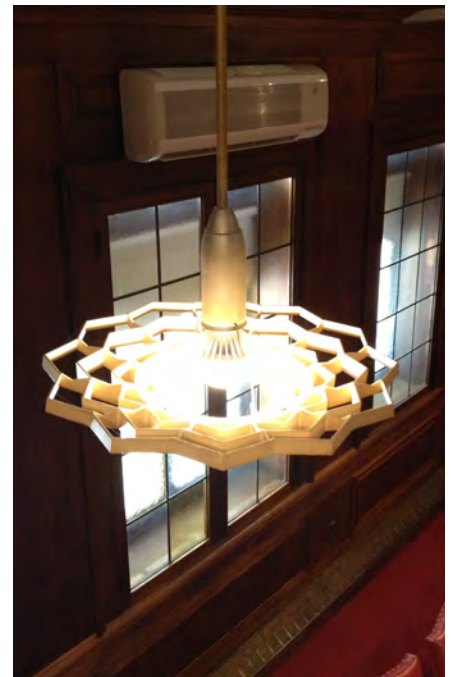


Fig. 210 - Existing pendant fixture & “Silverbowl” replacement lamp



Fig. 211 - Indoor split system unit

Architecture

The historic paneling and finishes in the Ackermann Room demand careful consideration in locating any new device. For this reason, we recommend integrating all new source equipment and the AV control module in a custom millwork unit located in the abandoned doorway on the room's East side (Fig. 212 & Fig. 213). This unit would be finished to match the wall paneling and its proportions would be designed to compliment and harmonize with the original architecture of the room. This approach minimizes disruption of the room's existing character, provides easy access to the back side of the unit (Fig. 214) for concealed power, data and video cabling, utilizes an existing opening and avoids the introduction of a new piece of furniture within the room. This built in casework will also provide a small work top, allowing the desk currently on the East wall of the room to be removed (Fig. 203).

Data, video and audio will need to be routed from the conference table to the display. A floor box, centered on the conference table is recommended. The associated rough will likely require repair or replacement of the existing carpet. The flat panel display will support the videoconferencing camera and loudspeakers from a single mounting point centered in the existing wood paneling. Blocking to support the display mount will likely be required and should be installed from the adjacent office to minimize damage to the wood panels. If the installed display projects more than 4" from the wall, a cane rail will be provided for accessibility purposes on the floor below the display. The cane rail and new track lighting should have a bronze finish to match the finishes on existing hardware and light fixtures. Consideration should also be given to relocating the 3 existing portraits that conflict with the new display and built in casework. The North wall is currently without portraits and has four unoccupied panels (Fig. 201).

Phasing Priority: 5



Fig 212. East door - closed



Fig 213. East door - open

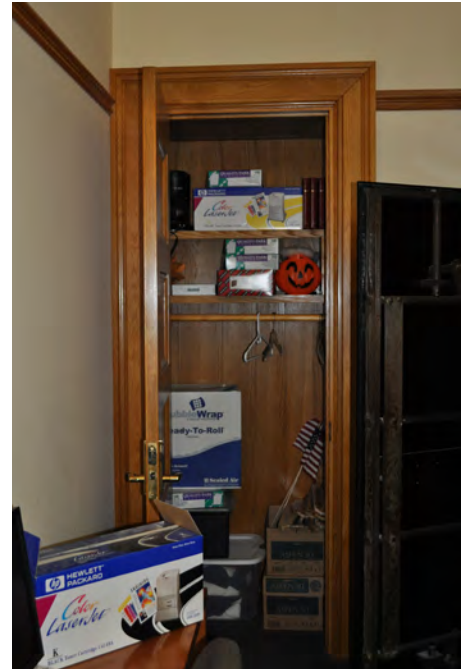
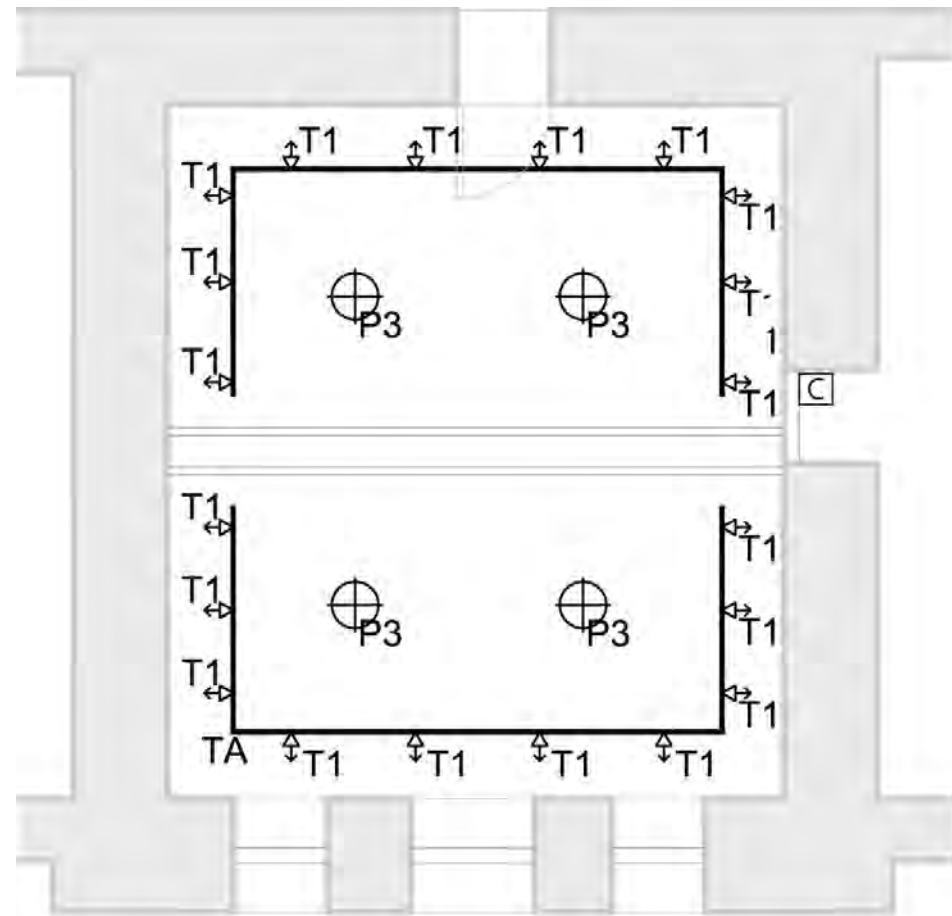


Fig 214. Backside of East Door
(City Council Administrative Offices)



P3 - Existing Pendant fixtures to be refit for higher wattage lamps

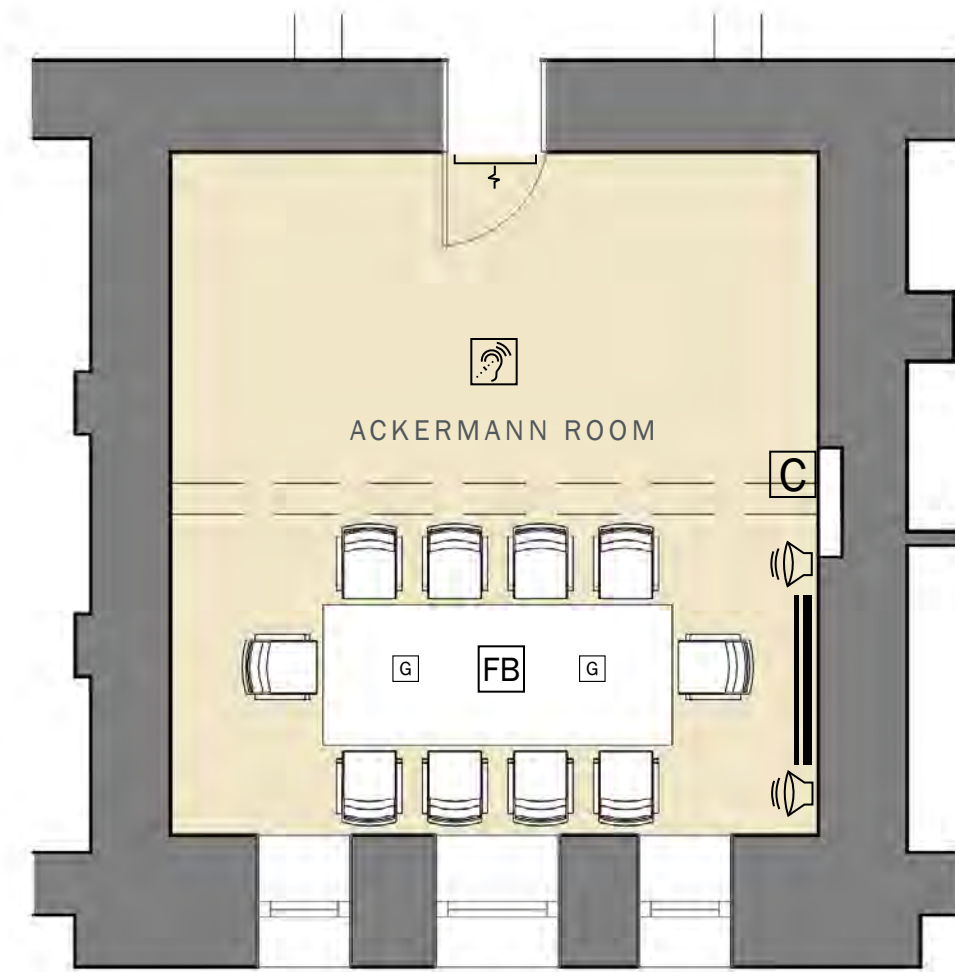
TA - Approx. 60 linear feet of 2-circuit track

T1 - LED track head

C - 4 zone Lutron Grafik Eye dimming control
OR 4 separate wall box dimmers.

NOTE - All existing track lighting in the room should be removed

Fig 215. Proposed Lighting Plan & Legend(Lam Partners)



LEGEND

- | | | | |
|--|-------------------|--|----------------------------|
| | Projection Screen | | Control Location |
| | Projector | | Assistive Listening System |
| | Loudspeaker | | Floor Box |
| | Video Camera | | Monitor |
| | Flip-Up Grommet | | Split system unit |

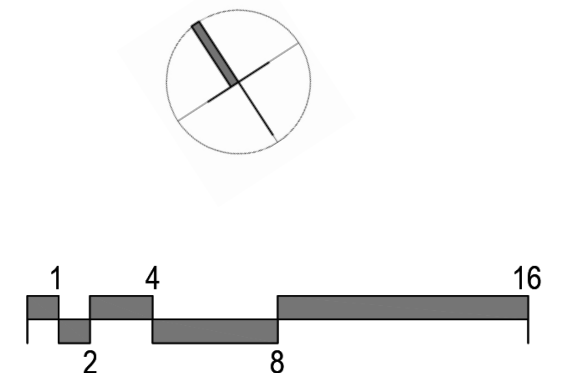


Fig 216. Proposed Floor Plan Diagram



INTERVENTION NO. 3: SOPHIE J. ANASTOS ROOM

INTERVENTION NO. 3: SOPHIE J. ANASTOS ROOM

Overview

The Sophie J. Anastos Room is a public meeting room located on the second floor of City Hall. The room has been renovated relatively recently, and the room finishes reflect this with a balance of painted plaster surfaces and detailed clear finished wood trim. As part of the last renovation, the room was outfitted with audio and video equipment for presentation. A through-window air conditioning unit provides cooling to the room on the room's South side. Because of the previous renovations to this space, the primary goal of this project is to upgrade the function of these A/V services and improve HVAC conditions in the room.

Observations & Existing Conditions

The room is well configured for the heavy use that it gets from City Hall staff. Recently renovated, the room finishes are in good condition, and it has the functionality required for presentations and conferencing. However, the existing Smart Board (Fig. 302) is currently located in a position (off of the room & conference table centerline) that is awkward for all attendees to view. The audiovisual infrastructure is outdated, difficult to use and does not support digital sources. The window air conditioner is sufficiently noisy to disrupt meetings, and the lighting, while providing good coverage of the room, casts uneven glow due to the size of the fixtures. A small worktop and credenza are located on the room's East side (Fig. 301).

Audio/Visual

- Removal & relocation of existing SmartBoard/Projector
- New video display on sliding mount
- New control module

The existing projector, Smartboard, and its enclosing cabinet will be removed and replaced by a 70" display monitor on a custom sliding mount (Fig. 305) that will enable the monitor to be centered on the conference table when in use. Loudspeakers will be provided at the display for audio projection. AV portable source equipment, such as laptop computers, will connect to the display system through new wall mounted inputs. The control module (Fig. 304) for Video display selection and audio levels will be located at the existing credenza (Fig. 301). A wall mounted connection will be provided to allow the City's portable assistive listening system to provide support to the hearing impaired. A conference telephone will be provided to enable any audio teleconferencing needs.

Acoustics

The most problematic acoustic issues in the space are due to mechanical noise and will be addressed through the installation of a new HVAC system. Sound isolation of the room will improve with the installation of perimeter gasketing, astragals, and automatic door bottoms. Any modifications to the door should be vetted with the project mechanical engineer, as the room relies on the entry door undercut for fresh air.



Fig. 301 - Existing Credenza



Fig. 302 - Existing Smartboard & Cabinet



Fig. 303 - Existing Projector



Fig. 304 - Control module

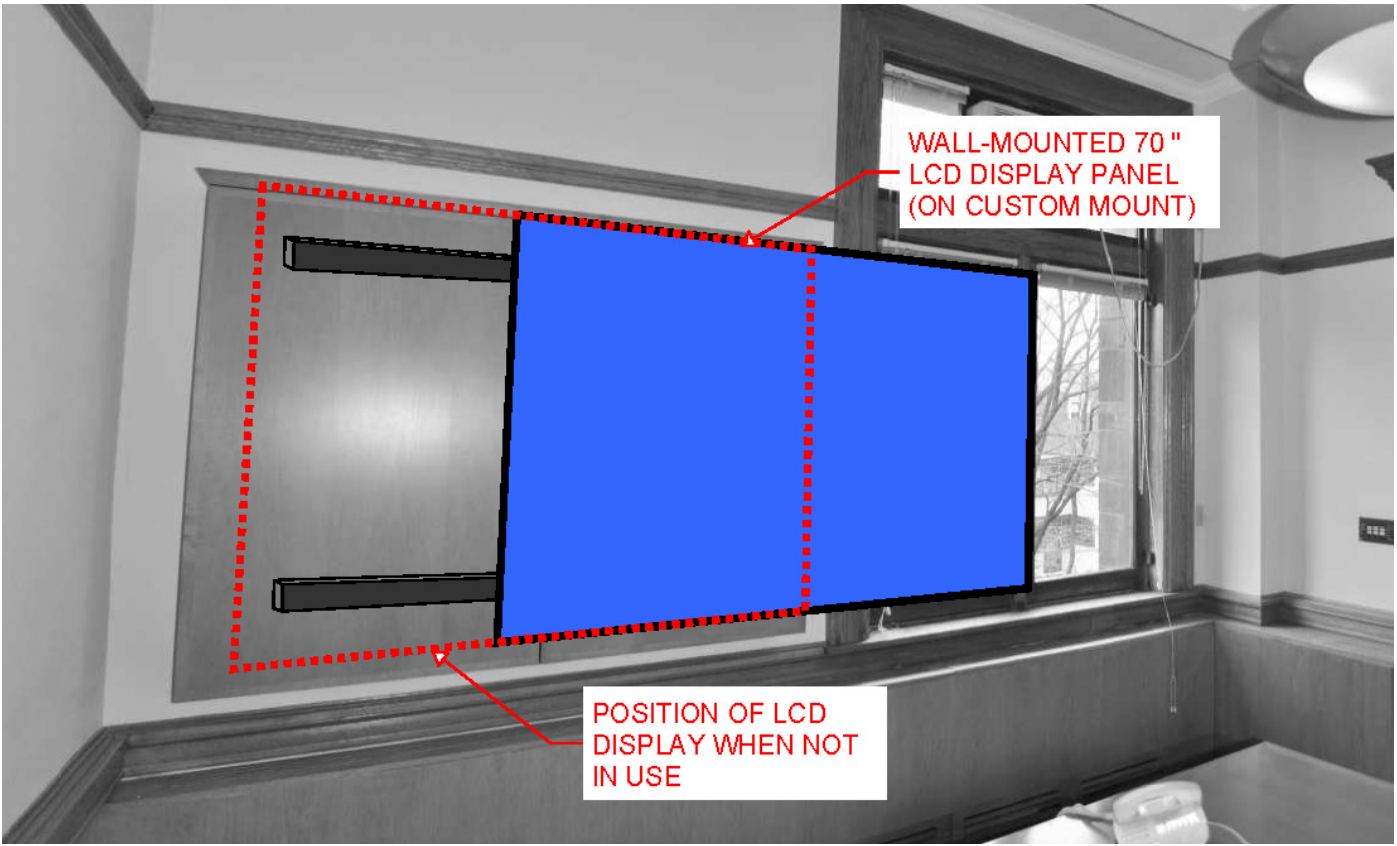


Fig. 305 - Diagram showing sliding mount for new flat panel (in operating position)

Lighting

- Cleaning of all fixtures
- Relamping of all fixtures

A thorough cleaning of all fixtures will improve the consistency of the light levels throughout the space. Additionally, replacing the lamps on all fixtures will be both more efficient and will provide consistent color temperature and greater efficiency. New LED lamps at the pendants will correct the current uneven glow at these fixtures (Fig. 306).

Mechanical

- New split system air conditioning unit / Removal of window unit

The existing window air conditioner (Fig. 307) should be removed and replaced with a ductless split system air conditioner. This new diffuser unit would be located high on one of the long walls of the room, and the condenser located in the building attic with others from other systems in the building.

Architecture

- Reglazing of demolished window AC unit
- Monitor support coordination
- Patching, finishing at rough in locations
- Window treatment for light control

The architectural scope of work in the Sophie Room is largely a matter of coordination with the other work planned for the room. There will need to be patching and painting at many locations where holes will be created or filled, such as the new split system, for example. More substantially, where the current window air conditioner is installed, new glazing will need to be provided to restore the window to its original condition. The control of daylight will be important on many occasions, as glare from the existing window can result in significant visual discomfort for viewers during a presentation on the flat panel monitor. A manual shade or drape would be appropriate for this location.

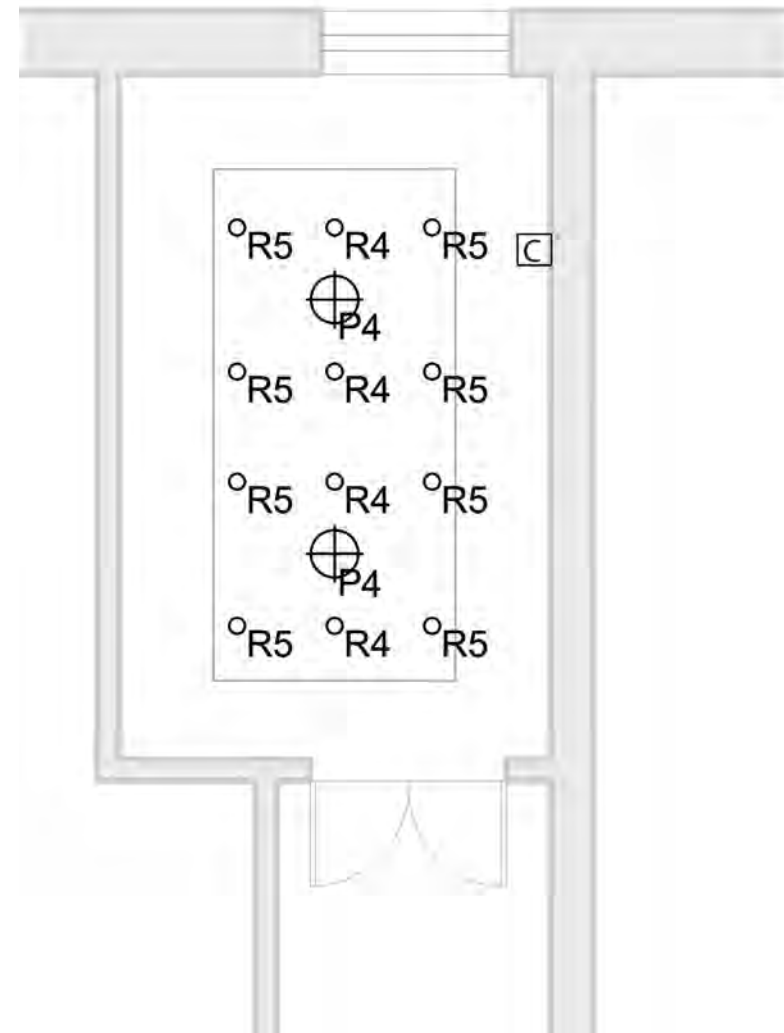
Phasing Priority: 6



Fig. 306 - Existing pendant fixture



Fig. 307 - Existing AC unit



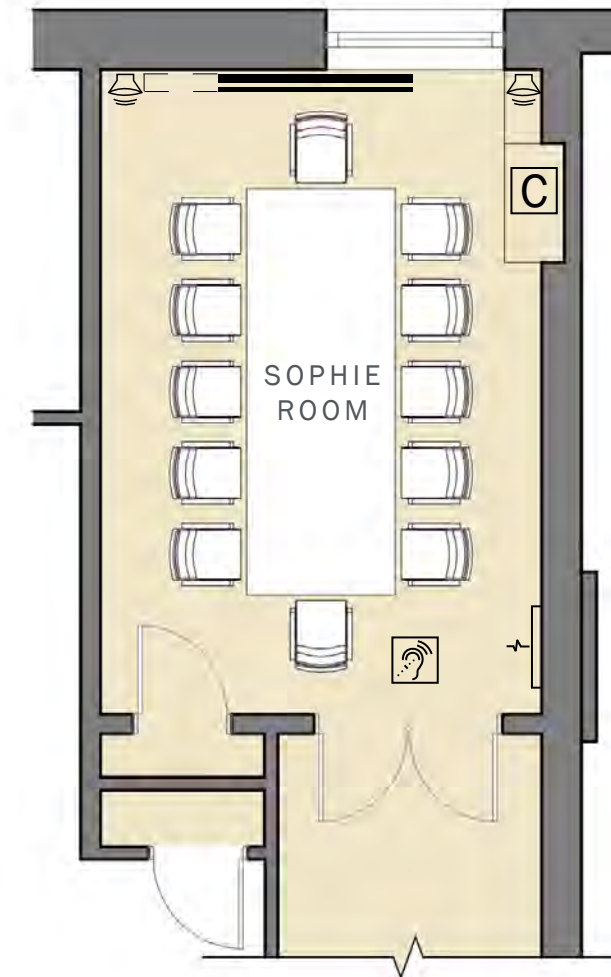
C - Existing controls to remain

P4 - Clean and Relamp existing pendant with new dimmable LED lamp

R4 - Clean and Relamp existing recessed downlight with new CFL lamp

R5 - Clean and Relamp existing recessed wall washer with new CFL lamp

Fig. 308 - Proposed Lighting Plan & Legend (Lam Parters)



LEGEND

- | | |
|-------------------|----------------------------|
| Projection Screen | Control Location |
| Projector | Assistive Listening System |
| Loudspeaker | Floor Box |
| Video Camera | Monitor |

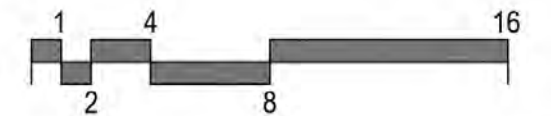
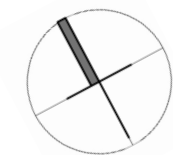


Fig. 309 - Proposed Floor Plan Diagram



INTERVENTION NO. 4: SENIOR CENTER

INTERVENTION NO. 4: SENIOR CENTER

Overview

The Senior Center Ballroom is used by a broad range of citizens for a wide variety of activities. The space currently suffers from poor acoustic isolation, inadequate audiovisual systems and significant sources of ambient noise, largely due to a flawed HVAC design. The space can be divided with a full height operable partition, but it is not providing the necessary acoustic isolation to prevent sound trespass. To achieve the City's goals for the space, including a suitable environment for Cable TV recording, the existing ceiling and HVAC system will need a considerable overhaul. The existing operable partition should be replaced and the existing audiovisual resources improved. The scope of work recommended for this intervention is significant enough to treat the Senior Center Ballroom as its own discrete project.

Observations & Existing Conditions

The space is currently illuminated with retrofitted compact fluorescent downlights and oversized pendant fixtures. The current light levels are adequate for most activities but existing fixtures have no dimming capability. The Ballroom suffers from mechanical noise due to high air velocity at supply diffusers (50% of which have been blanked off), return air velocity and audible vibration transmission from mechanical equipment. The existing ceiling mounted loudspeakers are functional and should continue to be used. Some impact noise was noted in the space as a result of activity in the classroom on the floor above. Many existing acoustic ceiling tiles are damaged by stains or abuse (Fig. 401 & Fig. 402).



Fig. 401 - Stained/damaged acoustic ceiling tile



Fig. 402 - Stained/damaged acoustic ceiling tile



Fig. 403 - View of entry area, lowered ceiling/fluorescent cove light & partition track



Fig. 404 - View of existing pendant fixtures, ceiling diffusers and glazed wall

Audio/Visual

- New Video Projection Screen & Loudspeakers (East wall)
- LCD screen on portable cart for extended viewing range
- Two new ceiling mounted projectors (East and West)
- Two wireless microphones & Assistive Listening system
- Reconfigured and enhanced loudspeaker system
- VCR/DVD player
- AV control system
- Fiberoptic connection to Cable TV control room



Fig. 405 - Digital video projector

New source equipment, projectors and reconfigured speaker systems will enable excellent audiovisual presentation quality and greater programming flexibility. New projection systems, a new motorized screen for the West wall and improved loudspeakers will allow quality video presentations in the ballroom for both closed (two-room) and open configurations of the operable partition. For presentations that utilize the entire space, a portable cart mounted with an LCD display to improve the viewing experience for those seated at the rear of the room. This was requested by the City, and is advisable given the relatively low ceiling height in the space.



Fig. 406 - Touchscreen control panel

The existing loudspeakers are suitable for reinstallation, but are too few in number and too far apart to provide even coverage for the Ballroom. These existing speakers will be supplemented with new ceiling mounted loudspeakers to reduce location spacing to 50% of the current spacing. An assistive listening system, wireless microphones and source equipment will be stored in the storage closets on either side of the ballroom.

Acoustics

- New acoustic ceiling tile & operable partition
- Perimeter velour curtains
- Entry Doors - Gasketing, astragals & automatic door bottoms
- Carpeting in Second Floor Classroom (Room #221)



Fig. 407 - Wireless microphone system

To achieve noise levels suitable for all of the programming desired in the Ballroom, the space should be designed to a level of NC-25. Background noise levels taken in the Ballroom ranged from NC-42 to NC-45, with the highest readings at the entrance to the room. Visible gaps are present at the base of the operable partition (Fig. 411) and sound isolation testing resulted in an NIC of 31, indicating that the partition is performing similarly to a solid wood door with no gasketing. A redesigned air distribution system is recommended (see Mechanical & Appendix A for more detail), along with mineral fiber acoustic ceiling panels with a minimum NRC rating of 0.70 and retractable velour curtains at the room perimeter (Fig. 412). The curtain fabric should be at least 14 oz. and will provide additional acoustic absorption and light control. Once the ambient noise is reduced, we anticipate that the poor sound isolation of the operable partition and entry doors will be even more noticeable and problematic. A new operable partition with an STC rating of 51 is recommended, and should be provided without an access door. Noise intrusion from the entry corridor is likely to create problems for broadcasting/recording and a full acoustic isolation fit out of the entry doors should be considered. Additionally, the provision of carpeting in the classroom above the ballroom will mitigate impact noise transmission to the Ballroom (Fig. 413).



Fig. 408 - Assistive listening system



Fig. 409 - Motorized projection screen

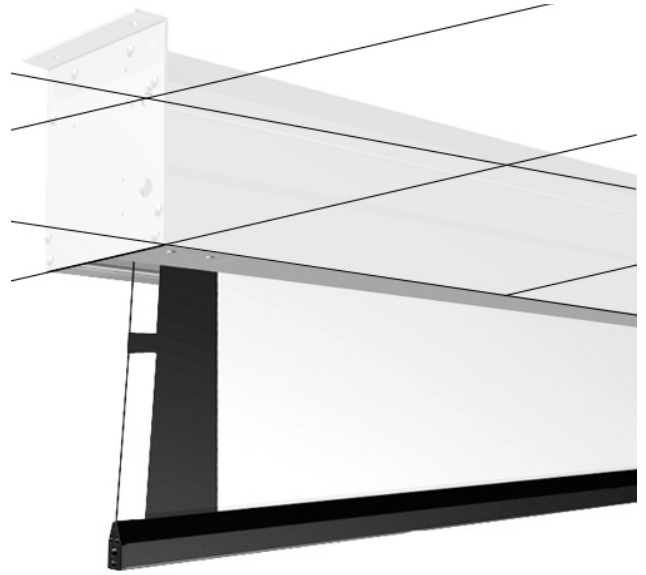


Fig. 410 - Recessed projection screen installation



Fig. 411 - Gaps in operable partition at floor level

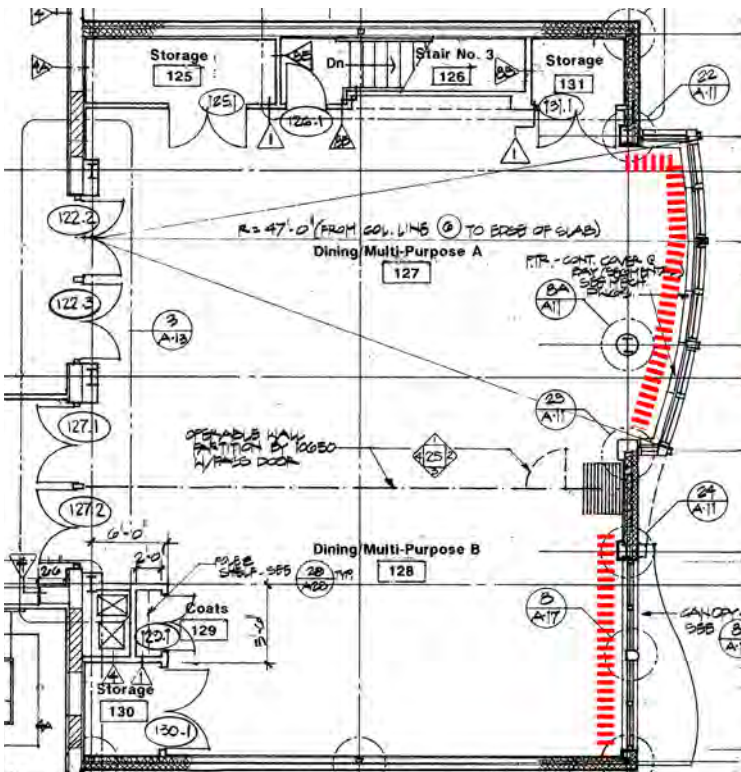


Fig. 412 - Diagram of perimeter velour curtains (Acentech)

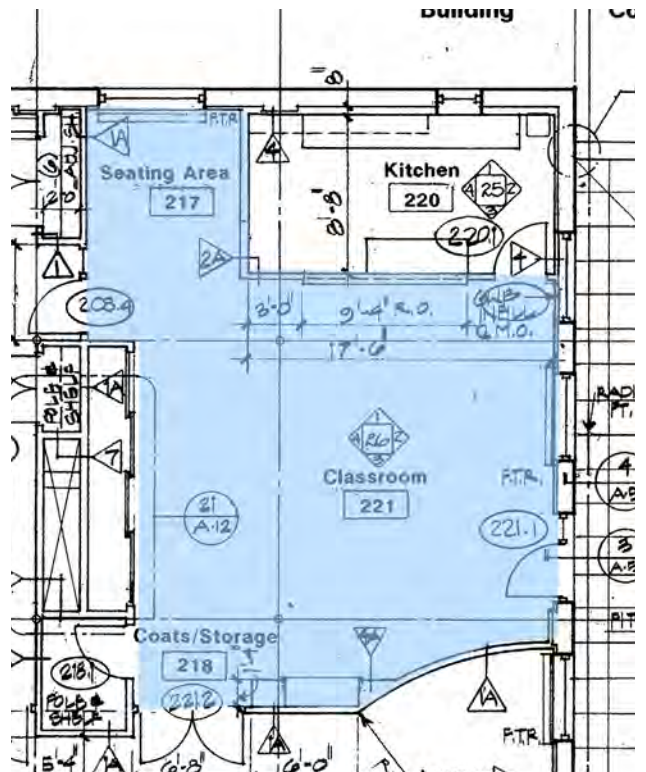


Fig. 413 - Diagram of proposed carpeting (Acentech)

Lighting

- Replace all existing fixtures
- Provide dimming capability for all fixtures
- Replace all existing switches

The scale of the existing pendant fixtures is inappropriate for the ballroom ceiling height and the efficiency of existing downlighting can be improved significantly. The pendant fixtures will be replaced with a new drum-type fixture that will not interfere with projection (Fig. 414 & Fig. 405). With new LED based lighting fixtures, it is estimated that the Ballroom will maintain the current lighting levels while using half the energy of the current system and provide greater flexibility to accommodate the evolving program needs of the space. At the lowered soffit near the room entry, the existing cove light (Fig 403) should be cleaned and relamped. The existing banks of switches should be replaced in their current locations with either wall-box dimmers or a scene -based Lutron Grafik Eye system (Fig. 415).

Mechanical

- Enlarged, acoustically lined supply air ducts
- Enlarged diffusers at perimeter window locations
- Enlarged return air grilles & slots
- Return air boot plenums
- New support for vertical duct runs
- Modified duct connections at rooftop units

The air system in the Ballroom currently generates significant unwanted noise from multiple sources. Each of these problems on its own might be suitable for a small renovation, but together they present the need for a full reconfiguration of all ductwork and supply/return locations in the space. Accommodating the duct dimensions required for quiet supply air delivery will necessitate lowering the ceiling 6 - 8 inches. The return air plenum and chase by the entry area (Fig. 418) in the room must be opened up to ensure that the enclosed ductwork is adequately supported and to provide the appropriate flex connectors to the roof top unit for both supply and return air. The existing rooftop unit will require service to resolve any internal sources of vibration. The condition and performance of rooftop equipment vibration isolators should also be evaluated (Fig. 416). Additionally, the rooftop ductwork (Fig. 417) is very poorly insulated and some leaks were noted at the roofbox/duct junction. It is imperative that these issues be addressed with improved waterproofing and the provision of a recommended 3" of rigid insulation on any ductwork exposed to the elements.



Fig. 414 - "S1" - Decorative Drum



Fig. 415 - Grafik Eye dimming system & 4-button lighting preset control panels



Fig. 416 - Rooftop equipment vibration isolator

Architecture

Unfortunately, there is little of the existing systems in the Ballroom ceiling that can and should be reused. A benefit of undertaking a full renovation of all the systems in the room (replacing the operable partition, removing the architectural ceiling tile system, air system and lighting) is that new work can be completed more quickly than a partial renovation. The coordination of all systems engaging the new ceiling – lighting, HVAC, audiovisual devices, fire protection and the specification of the ceiling itself is critical. Duct sizing and configuration must be refined to allow the maximum ceiling height possible. Light fixture locations and types need to be carefully vetted to ensure that there are no obstructions for video projection. The specification, detailing and installation of the new operable partition will be important to realize the level of sound isolation required when the partition is deployed. Ancillary work required to support the partition, extend the acoustic isolation into the ceiling cavity above and reconstruct the finish walls of the vertical chase should also be included in the scope of this intervention.

Implementation

The heavy use of the Senior Center and the Ballroom in particular will require a tight construction schedule and adequate notice for the public. The Senior Center is a refuge for many older residents in the summer months and the construction activity in the Ballroom may require the closure of adjacent spaces as well.

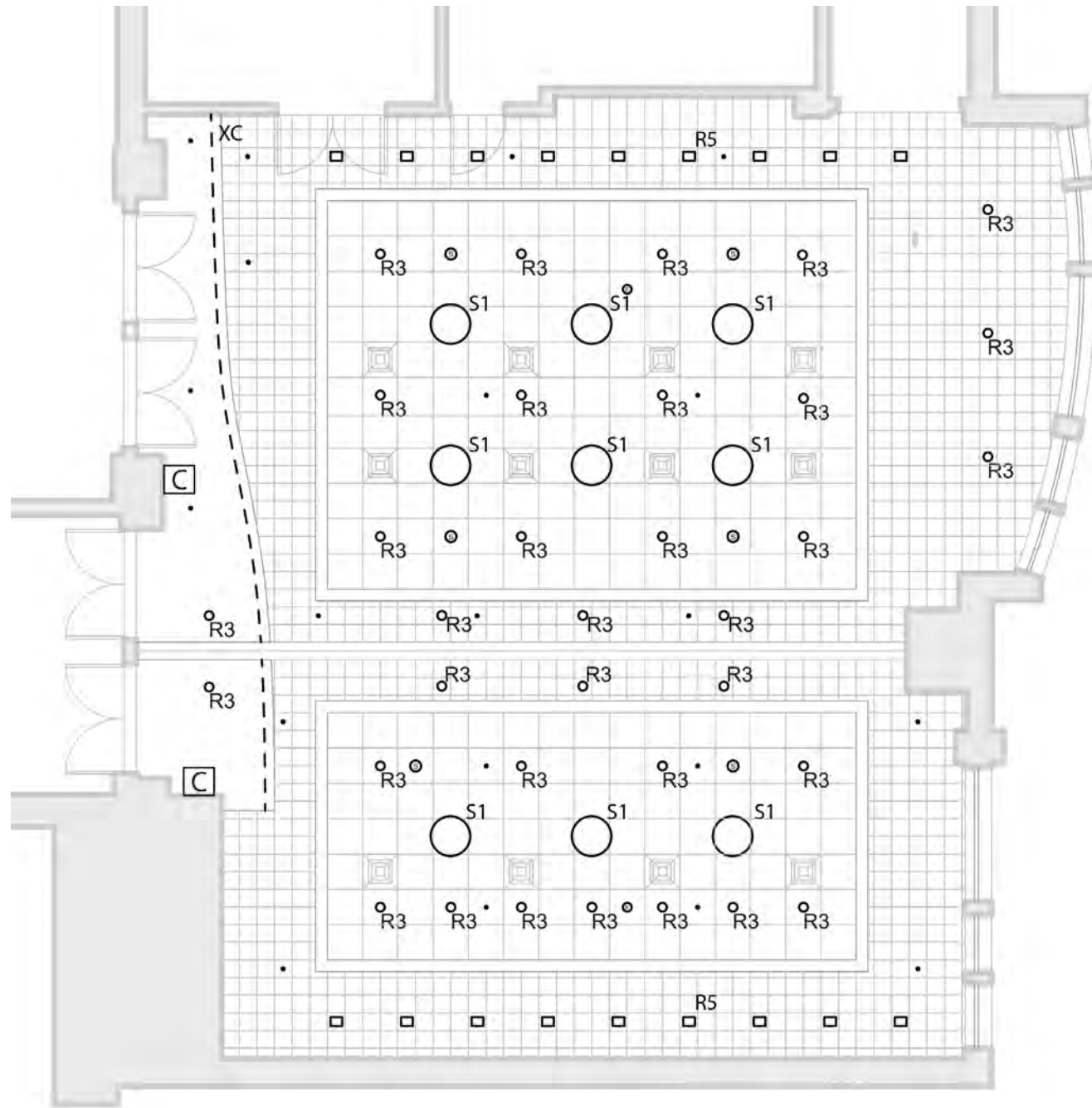
Phasing Priority: 2



Fig. 417. Uninsulated, deteriorating ductwork at rooftop equipment

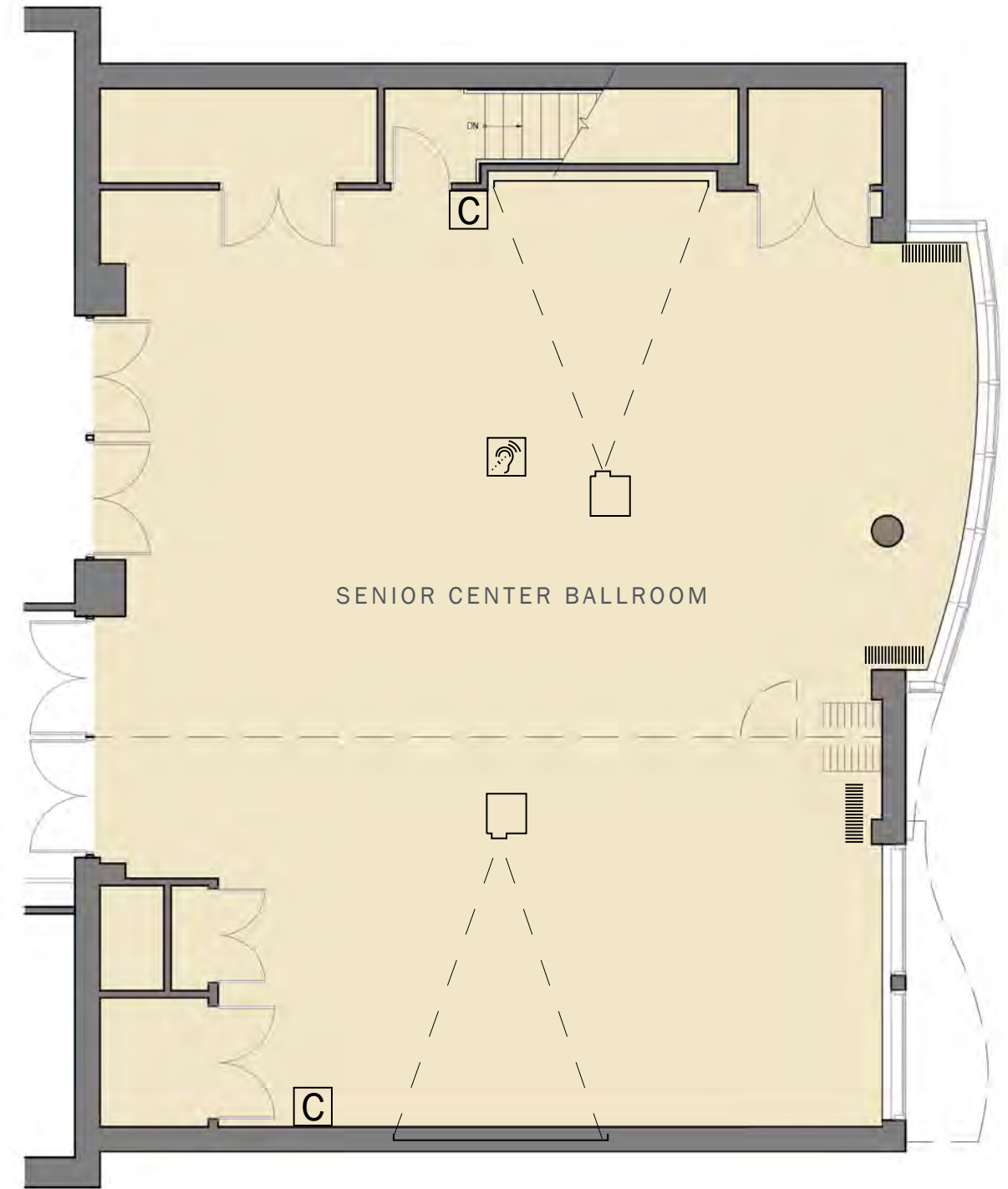


Fig. 418. Soffit at return air plenum at ballroom entry



S1 - New "drum" fixture
R3 - New dimmable LED R3 downlight
R5 - New dimmable R5 LED washlight
XC - Existing fluorescent cove

Fig. 419 - Proposed Lighting Plan & Legend (Lam Partners)



LEGEND

- | | | | |
|--|-------------------|--|----------------------------|
| | Projection Screen | | Control Location |
| | Projector | | Assistive Listening System |
| | Loudspeaker | | Floor Box |
| | Video Camera | | Monitor |
| | Velour Curtains | | |

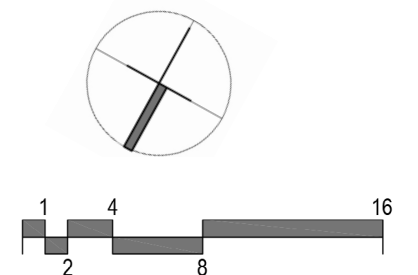


Fig. 420 - Proposed Floor Plan Diagram



INTERVENTION NO. 5: CITY HALL ANNEX

INTERVENTION NO. 5: CITY HALL ANNEX

Overview

The City Hall Annex Community Room is a meeting room located on the second floor of 344 Broadway and is open to the public. Lighting, projection, AV source inputs and controls are already installed but functionality can be improved. There is a large control room adjacent to the space that is outfitted with a complex AV system that is difficult to operate and complicated by security/access concerns.

Observations & Existing conditions

The HVAC system is generally quiet, but one sidewall return register at the south wall is generating significant ambient noise that was measured at NC-38. This noise should be addressed to achieve acceptable sound levels for audiovisual presentations. Supply air is provided from floor registers (Fig. 508), one of which appear to be delivering very little air volume. The “front” of the room alternates between the West wall opposite the entry doors (for most public hearings) and the North wall to the right of the entry for projected presentations. An illuminated accent wall, between the two entry doors could also serve as a presentation location (Fig. 509). The circuiting of the room does not allow the appropriate zoning of light fixtures to support the room’s different configurations. Existing manually controlled blinds provide adequate daylight control.

Audio/Visual

- Digital connections for laptop computers
- New digital video projector (existing projection screen to remain)
- Blu-ray/DVD player
- Connections for portable av equipment
- Two (2) wireless microphones
- Wireless assistive listening system
- New AV touchscreen control panel

The existing AV system (Fig. 505) is extremely complex and so difficult to operate that it is rarely used. The projection system does not support digital sources and the City lacks the proprietary software to alter the system programming. A new digital video projector (Fig. 501) can be combined with the existing screen (Fig. 507). The AV system should be redesigned to provide easy operation and meet the current needs of the room. New wireless microphones for speech reinforcement will be coupled with the existing loudspeakers and a digital processor that will mix and process audio for optimal performance. A project-standard control touchpanel (Fig. 502) will be programmed for the required control functions: projector display options, audio volume levels, video and audio source selection. The control will also be linked to the City data network, allowing simple operation and technical staff to remotely assess system functions in support of users.

Acoustics

Site investigations found airflow at the problematic return air register to be far above recommended levels, creating unacceptable levels of background noise in the space. Given that the room’s primary purpose is AV presentation, reduce noise levels should be reduced to NC-30. By modifying the existing ductwork and return grilles, the desired noise reduction can be reached. See Mechanical for more detail on this approach.



Fig. 501 - Digital video projector



Fig. 502 - Touchscreen control panel



Fig. 503 - Wireless microphone system



Fig. 504 - Assistive listening system



Fig 506 - Existing projector & opening to Control Room



Fig. 505 - Existing audiovisual equipment



Fig. 507 - Existing projection screen

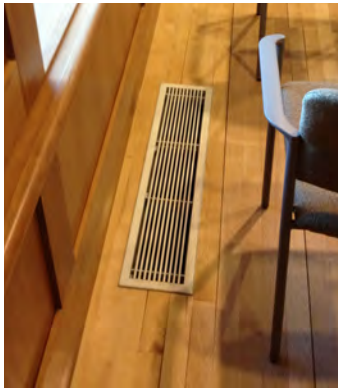


Fig. 508 - Existing floor diffuser

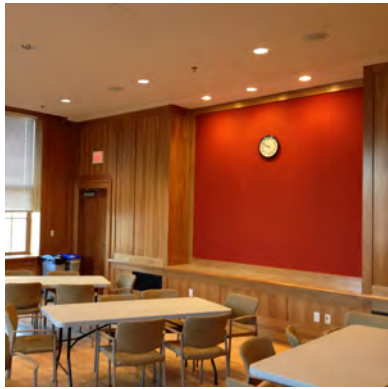


Fig. 509 - Accent wall

Lighting

- Cleaning & relamping of all fixtures
- Reconfigured lighting zones & switching

The recent renovation of the Community Room requires little in the way of new fixtures, but switching and fixture efficiency can be improved. Cleaning and relamping of all existing fixtures with 3000k compact fluorescent bulbs is recommended. The proposed new switching scheme provides superior lighting conditions for each presentation location while maintaining appropriate light levels at the back of the room (Zone "A", Fig. 511).

Mechanical

- Ductwork extension into dropped ceiling
- Two (2) new ceiling registers & plenums

In order to address the problematic noise from the sidewall return air grille, the air velocity at the grille location must be reduced. The recommended approach to this problem is to extend the ductwork from the sidewall into the dropped area of the ceiling, widen the ducts once they enter the ceiling, and add two new ceiling grilles with plenum boxes. This will split the required volume of air between the two locations and result in quieter operation. Additionally, it is recommended that the room be re-balanced to verify the total airflow after renovation.

Architecture

- Coordination of ceiling elements
- Construction & finishes related to HVAC modifications
- Lectern to contain control module, source equipment, microphones & listening devices
- Floor box connection at lectern position

The primary architectural considerations in the Community Room are the construction surrounding the renovated ductwork, integration of new AV components and coordination with existing light fixtures and av components. New source equipment and the AV control panel should be mounted to a new lectern for the space that can connect directly to a floor box below (Fig. 512). The control module could also be mounted to the adjacent wall. If a floor box is not possible due to budget constraints or unforeseen field conditions, a wall box is acceptable but the associated cables are potential tripping hazard. The precise location and finish of all new switches, patching and finishing associated with the new ductwork, as well as the selection of finishes for new ceiling registers are all within the architectural scope of the proposed work. Additionally, the specification of the preferred mode of access for the control room will need to be coordinated with the City's security vendor if electronic access is desired, or in final contract drawings for simple keyed access.

Phasing Priority: 4

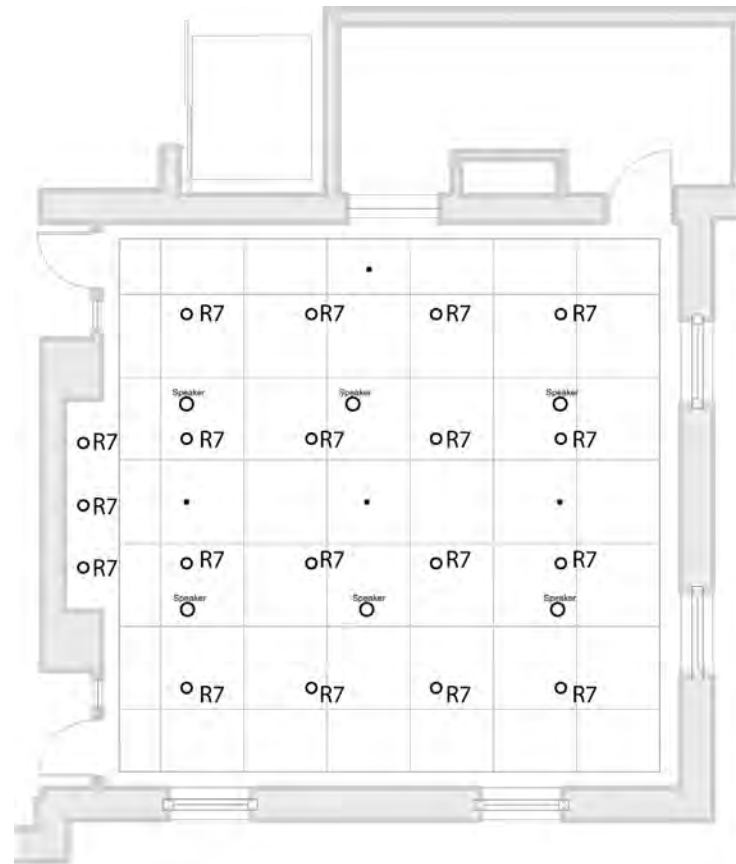


Fig. 510 - Proposed Lighting Plan
Clean and relamp existing recessed downlights "R7" with new CFL lamps. (Lam Partners)

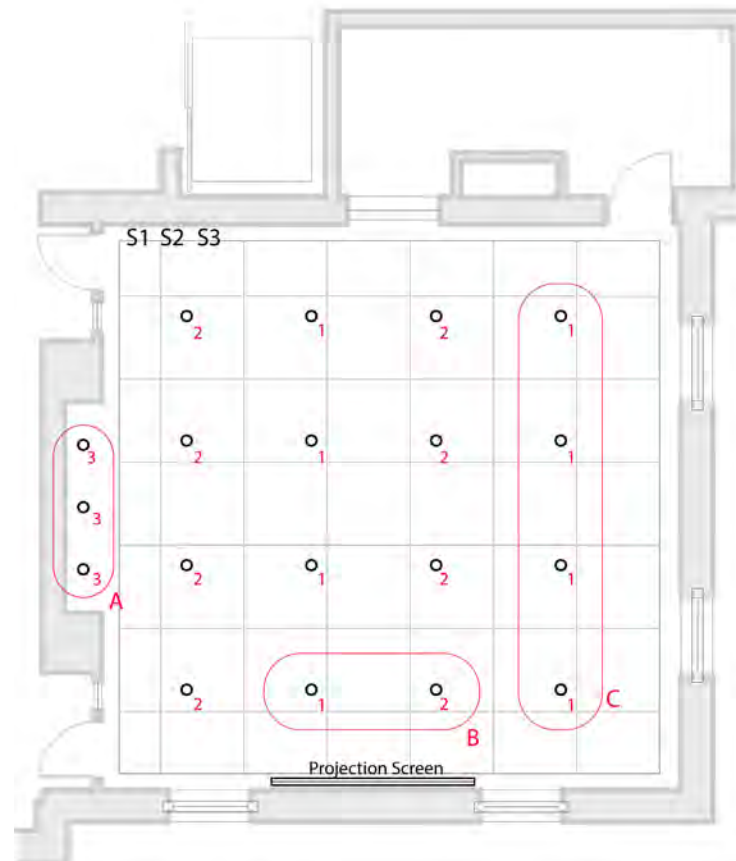


Fig. 511 - Proposed Switching/Circuit Diagram
Allows for three separate zones to coincide with flexible presentation spaces. (Lam Partners)



LEGEND

- | | | | |
|--|-------------------|--|----------------------------|
| | Projection Screen | | Control Location |
| | Projector | | Assistive Listening System |
| | Loudspeaker | | Floor Box |
| | Video Camera | | Monitor |

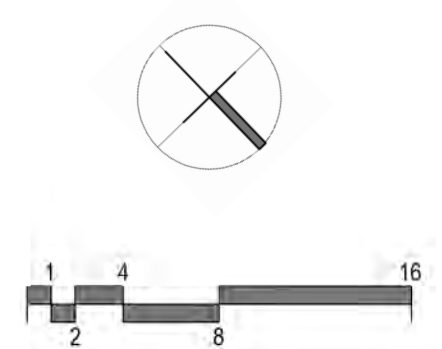


Fig. 512 - Proposed floor plan diagram



INTERVENTION NO. 6: WATERWORKS

INTERVENTION NO. 6: WATERWORKS

Overview

The Cambridge Water Department at 250 Fresh Pond Parkway possesses a spacious daylight lobby that has recently been renovated and is used with increasing frequency for City functions. The terrazzo floors and height of the space present less than ideal acoustic conditions. The lobby space also contains a vestibule and a stair to a mezzanine. A combination of acoustic absorption, speech reinforcement and minor lighting adjustments will significantly improve intelligibility and presentation quality in one of the City's most impressive public spaces.

Observations & existing conditions

There is ample full height glazing in the lobby, allowing daylight to flood the space. Glazed walls separate the lobby from the heavy equipment in adjacent spaces, but do not provide any acoustic isolation. When nearby pumps are not operating, the space has very little ambient noise. Long reverberation times (3.5 seconds) due the terrazzo floor, room height and wall finishes make intelligibility very poor with the temporary sound systems currently in use. The coffered, curved ceilings have the unintended consequence of acoustical focusing rather than evenly distributing the reflected sound. Light fixtures are relatively new and consist of compact fluorescent wall sconces, compact fluorescent pendants and metal halide downlights. There are currently no aimable fixtures installed.

Audio/visual

- Steerable column loudspeaker system
- Assistive listening connection
- AV control panel
- (Portable AV system)

The cost and complexity of light control in this heavily glazed space makes a permanent video display ill-advised. Video capability can be introduced to the space with the Portable AV system. A single, steerable column loudspeaker system is recommended to improve intelligibility (Fig. 601 & Fig. 602). A button-type control module, wireless microphones and a connection for the City's portable assistive listening system should also be provided.

Acoustics

- Acoustic treatments on walls and ceiling
- Gasketing and thresholds at interior doors

A suitable target reverberation time for this space is 1.0 second or less. To achieve this level of performance, approximately 2800 sf of acoustic treatment needs to be applied to the ceilings and walls of the lobby. The material should be directly applied and have an NRC of .70 (see Appendix A for more detail). The ceiling coffers and curved ceiling areas should all receive acoustical treatment (Fig. 603, 604 & 605). The walls of the vestibule and flat ceiling areas should also be considered. The interior doors located behind the reception desk and in the elevator lobby should receive gasketing and thresholds to improve acoustic isolation from the adjacent pump rooms.



Fig. 601 - Column loudspeaker



Fig. 602 - Proposed speaker location

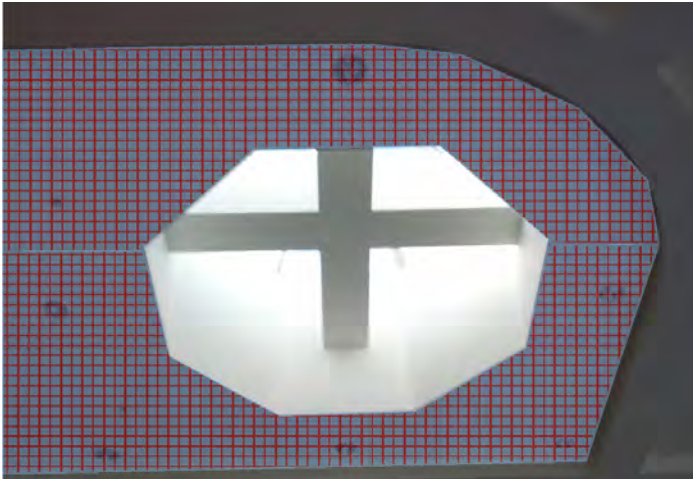


Fig. 603 - Central Coffier

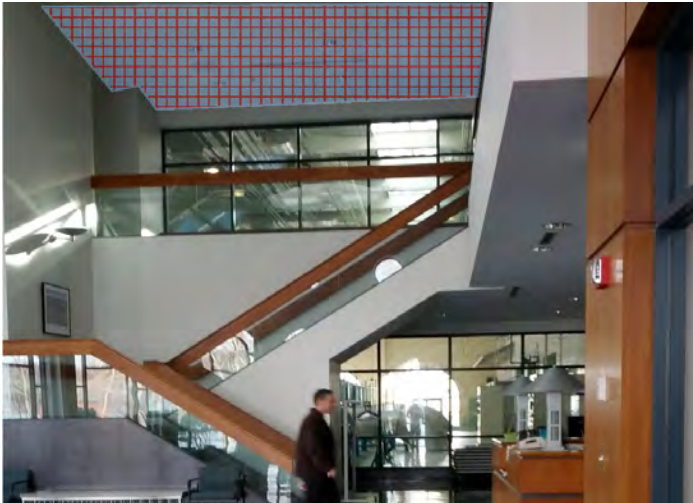


Fig. 604 - Mezzanine Ceiling



Fig. 605 - Curved ceiling coffers

Lighting

- Clean and re-lamp pendants & sconces
- Re-lamp downlights & provide dimming capability
- Replace 3-5 downlights with adjustable fixtures

The lighting in the lobby is not configured for presentations. Existing lighting lacks dimming capability and any aimable fixtures capable of highlighting presentation speakers. The introduction of dimming for existing downlights will provide added flexibility for general lighting levels and replacement adjustable accent fixtures would provide the ability to properly illuminate several “core” presentation formats.

Architecture

Architectural design scope for the proposed intervention should include the composition of acoustic treatments and their integration into the existing architecture, color selection of acoustic finish materials, mounting of the new column loudspeaker system, the coordination of AV control locations and the development of preferred presentation seating layouts to inform changes to the existing lighting design.

Phasing Priority: n/a



Fig. 606 - View of Mezzanine



Fig. 607 - View of Entry Vestibule



Fig. 608 - View of Lobby Fountain
(above & right)

LEGEND:

- R8 Clean and Relamp existing recessed downlight
- R9 Clean and Relamp existing recessed downlight
- P5 Clean and Relamp existing Pendant fixture
- P6 Clean and Relamp existing Pendant fixture
- W3 Clean and Relamp existing wall sconces
- L1 Clean and Relamp existing linear uplights

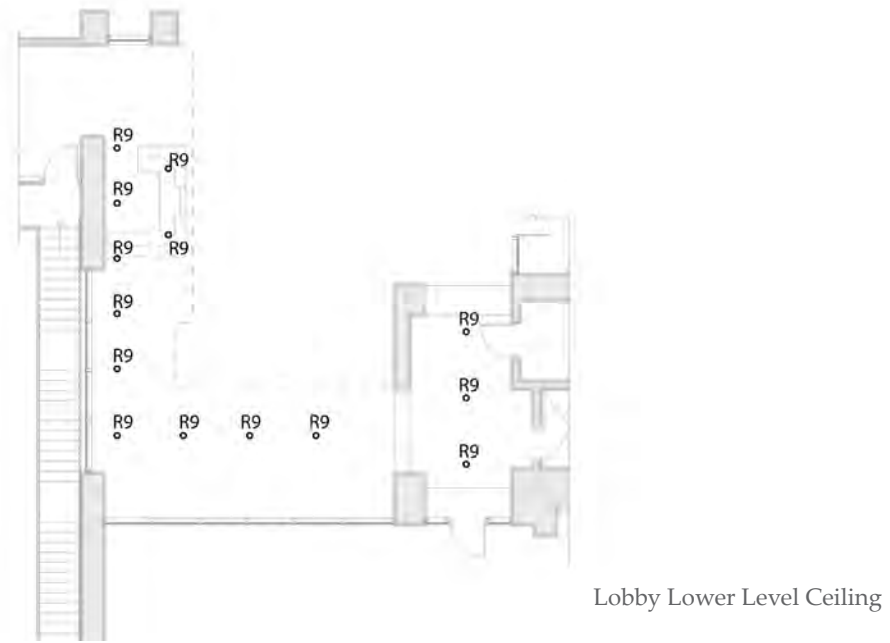
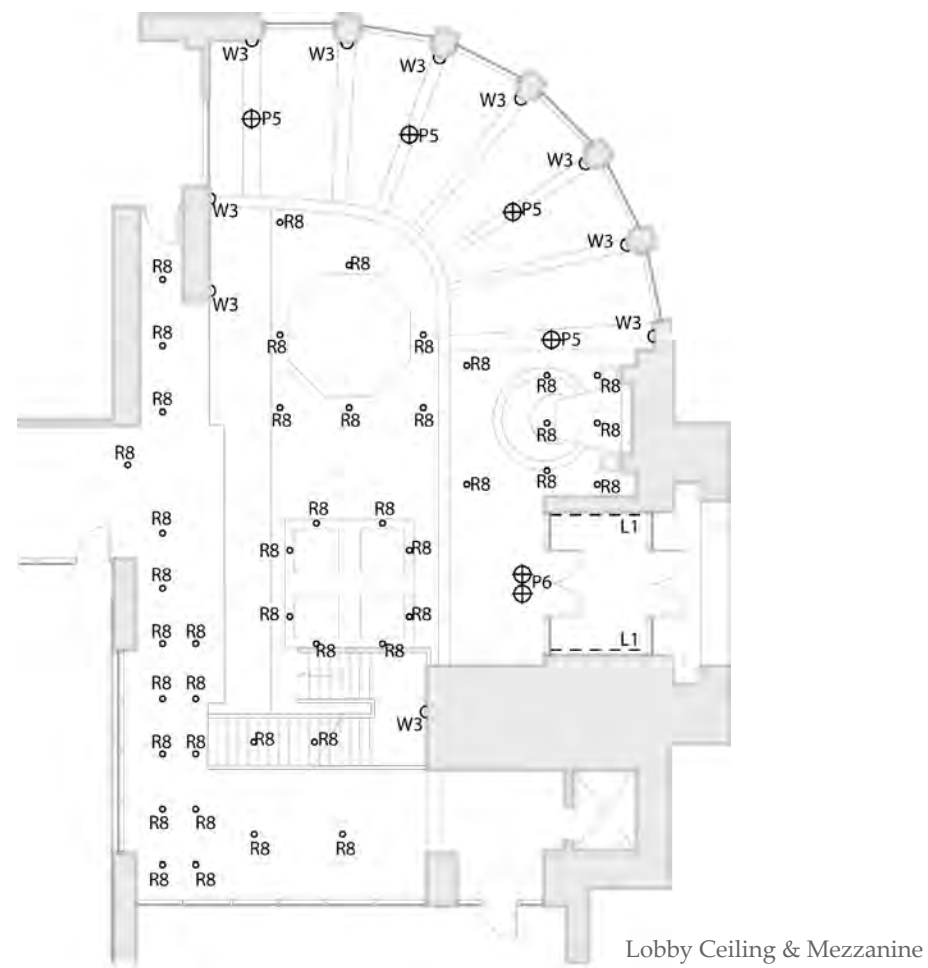
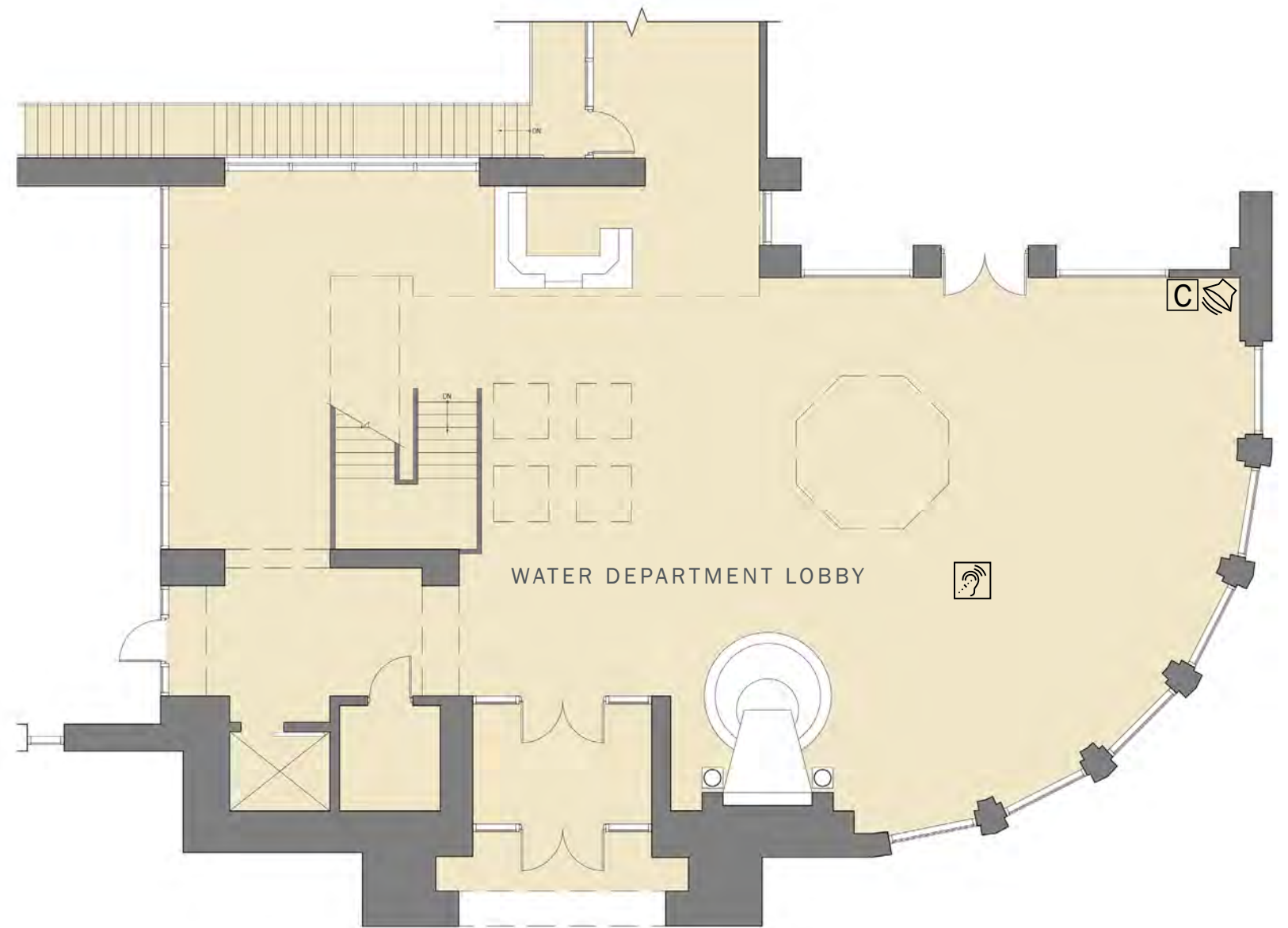


Fig. 609 - Proposed Lighting Plan (Lam Partners)



LEGEND

- | | | | |
|--|-------------------|--|----------------------------|
| | Projection Screen | | Control Location |
| | Projector | | Assistive Listening System |
| | Loudspeaker | | Floor Box |
| | Video Camera | | Monitor |

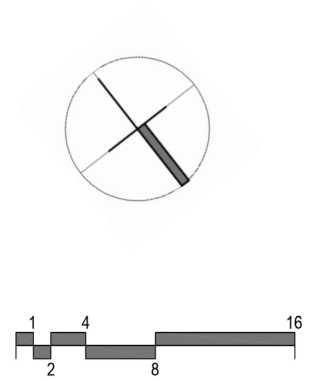


Fig. 609 - Proposed floor plan diagram



INTERVENTION NO. 7: LOMBARDI ROOM

INTERVENTION NO. 7: LOMBARDI ROOM

Overview

The Lombardi Room is a rectangular multipurpose meeting room in the basement of 831 Massachusetts Avenue and is operated by the Cambridge License Commission. Goals for the space include a digital projection system, improved general lighting, lighting performance and speech reinforcement. The room is used frequently for regular licensing hearings and can also be booked for internal city use. Recommended interventions are focused on the reduction of ambient noise and the addition of video projection capability.

Observations & existing conditions

This meeting room has a low, dropped acoustic ceiling with 2x4 troffer fixtures and incandescent downlights. Walls are painted GWB and the floor is carpeted. Furniture is arranged for licensing hearings, but all pieces are movable. The room is already equipped with an assistive listening system that is critical due to the high level of ambient mechanical noise. Two VAV boxes are supplying air to the space, one serving two diffusers and the other serving three. Supply air is controlled by one thermostat in the room and another in the adjacent room. Such a configuration is prone to occupant comfort issues, as the thermostats “compete”. The problematic noise is due to inadequate duct and diffuser size.

Audio/visual

- Ceiling mounted digital projector
- Manual roll down projection screen

A ceiling mounted digital projector will be provided (Fig. 704), displaying media on a wall mounted, 92” wide manual roll down projection screen (Fig. 705). AV portable source equipment, such as laptop computers, will connect to the projection system through new wall mounted inputs. Video display and audio levels will be selected through a new wall mounted control module. The existing speech reinforcement system (loudspeakers and amplifier) will be retained and will be more effective once measures are taken to reduce mechanical noise. A wall mounted connection will be provided to allow the City’s portable assistive listening system (Fig. 703) to provide support to the hearing impaired. A conference telephone will be provided to enable any audio teleconferencing needs.

Acoustics

The existing mechanical air distribution ducts create an unacceptable level of ambient noise, measured at NC-40, even with a full acoustical ceiling. An appropriate background noise level is NC-25. The finishes in the room are suitable, therefore a renovation of the room HVAC distribution system is the best course of action to improve room acoustics. See the Mechanical section below for details on the proposed scope of work.



Fig. 701 - Existing conditions (note “scalloping” from existing fixtures)



Fig. 702 - Room entrance



Fig. 703 - Hearing assistance badge



Fig. 704 - Digital video projector (ceiling mounted)



Fig. 705 - Video projection screen (recessed)

Lighting

- New light fixtures

The existing lighting design is straightforward, but the 2x4 parabolic troffers and the incandescent recessed downlights are very inefficient (Fig. 706). Originally celebrated for their ability to reduce glare on computer screens, parabolic troffers create a cave-like effect and produce sharp “scalping” on adjacent walls (Fig. 701 & Fig. 707). Additionally, the layout is asymmetrical and has no dimming capability – a critical feature for any flexible presentation room. The existing downlights should be removed entirely, and the existing 2x4 parabolic troffers should be replaced with more efficient 1x4 volumetric troffers (Fig. 708 & Fig. 710).

Mechanical

- New low pressure/low velocity ductwork
- Six new supply air diffusers
- New dedicated VAV box
- Additional return air grille

The HVAC system should be reconfigured so a dedicated VAV box serves the space. The VAV box supplying two diffusers should be removed and replaced with a new 660 cfm VAV box (Fig. 709) with a hot water coil and discharge sound attenuator. The ductwork from the VAV box controlled by the thermostat in the adjacent space should be removed as well as the associated diffusers. New acoustically insulated, low pressure, low velocity ductwork and six new diffusers should be installed along with one additional return grille.

Architecture

- Recessed installation of projection screen
- Coordination of ceiling components

The proposed interventions for the Lombardi Room will require little in the way of new architectural elements. Ideally, the ceiling grid would be rearranged at the head of the room to allow the projection screen housing to sit above the ceiling plane. Recessing the housing is advantageous with such a low ceiling as it will limit obstruction of the whiteboard and provide the maximum available screen area possible. Beyond the patching and finishing where new devices are installed (control modules, dimming switches, source connections), the architectural focus should be on the arrangement of devices in the ceiling. New light locations and projector mount must be carefully coordinated with existing sprinkler locations, ceiling modifications and HVAC equipment.

Implementation

The City of Cambridge instructed the design team to indicate that for the purposes of this study, improvements to the Lombardi room will be funded through the License Commission. The report’s recommendations are still valid and appropriate, but will be executed at the discretion of City government and as permitted by License Commission budgeting.

Phasing Priority: n/a



Fig. 706 - Existing incandescent lamp

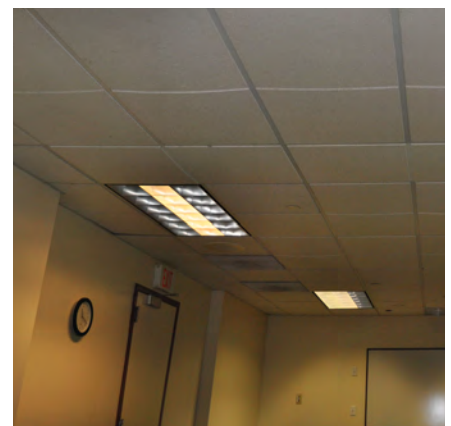


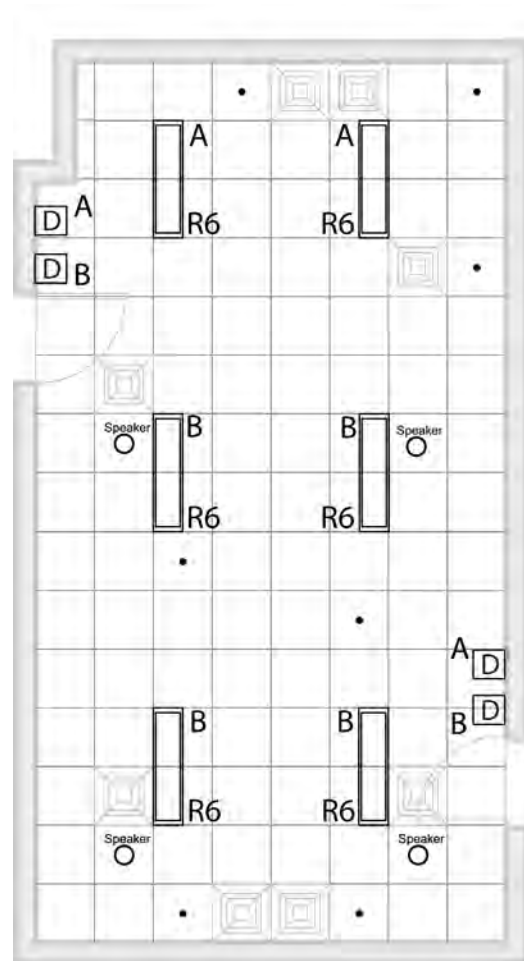
Fig. 707 - “Scalping” from existing fixtures



Fig. 708 - 1x4 Volumetric Troffer

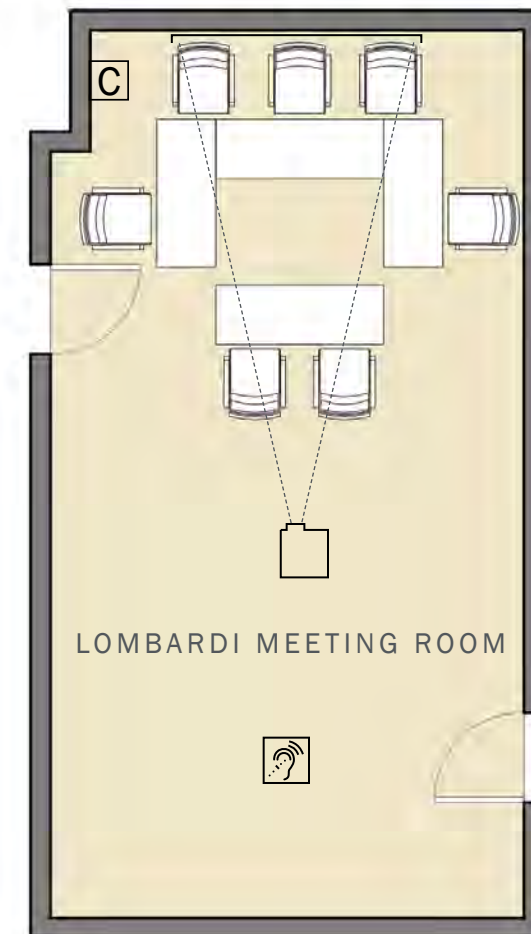


Fig. 709 - Variable air volume (VAV) box



- R6 New dimmable volumetric 1x4 fluorescent troffers
- D New fluorescent 3-way wall box dimmer.
 - A. Controls 2 (two) R6 fixtures in the front of the room.
 - B. Controls 4 (four) R6 fixtures in the center & rear of the room.

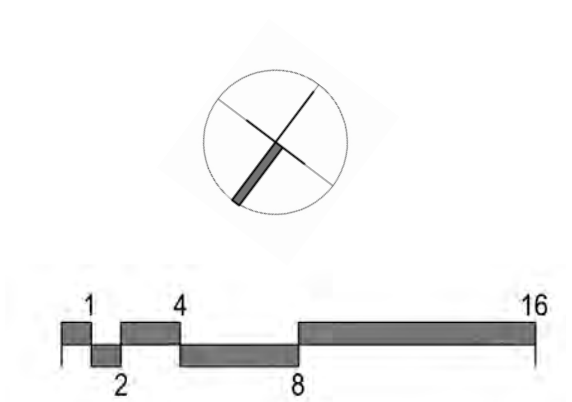
Fig. 710 - Proposed Lighting Plan & Legend (Lam Partners)



LEGEND

- | | |
|-------------------|----------------------------|
| Projection Screen | Control Location |
| Projector | Assistive Listening System |
| Loudspeaker | Floor Box |
| Video Camera | Monitor |

Fig. 711 - Proposed floor plan diagram





INTERVENTION NO. 8: PORTABLE A/V SYSTEM

INTERVENTION NO. 8: PORTABLE A/V SYSTEM

Overview

A portable audiovisual system is critical tool for both public and internal presentations. The development of this system will enable the City to expand its range of potential presentation venues while providing a integrated set of flexible, high performance and mobile audiovisual tools. With the equipment specifications outlined in this report, the city can commission multiple units to further expand its audiovisual capabilities. This unit can also function as a “bridge” to provide improved, temporary functionality in spaces where more extensive, permanent audiovisual improvements are being made.

Observations & existing conditions

The City’s options for presentation venues are limited to those spaces currently outfitted with audiovisual systems, as existing portable system options are inadequate and diffuse. The City is often in need of a “go-anywhere” presentation system for building dedications, public events and other venues that lack any system infrastructure. This proposed system would be very well suited to transform a space like the Water Department lobby into a highly effective presentation space.

Audio/visual

- Portable projection screen, mountable on equipment cart
- VCR & DVD/Blu-ray combination player
- Input for portable audio devices & video equipment
- Digital inputs for laptops
- Analog VGA connection
- Wireless microphones & assistive listening system
- Powered loudspeakers (2)
- Integral control module
- Shock-mounted, castered “road case”

The portable AV unit will be mobile, durable and provide a complete audiovisual setup in virtually any location that can provide power. Source equipment provided will support a broad range of media formats and can be adapted to suit the City’s needs. The unit will be sized to allow movement and installation by one to two people, depending on the vehicle in which the system is transported.

Architecture & additional considerations

This particular intervention is equipment based, but the City would be well served to identify typical locations that the Portable AV unit will likely be deployed. Testing the unit in various spaces will reveal preferred seating layouts, power locations and any particular challenges presented by a particular room. With respect to projection screens, the City may want to consider a variety of sizes. The unit could be set up anywhere from a small meeting room to an outdoor plaza.

Phasing Priority: 3



Fig. 801 - Shock resistant road case



Fig. 802 - Wireless microphone system



Fig. 803 - Portable video projector



Fig. 804 - Portable loudspeaker



Fig. 805 - Portable projection screen

III. IMPLEMENTATION & PHASING

A. IMPLEMENTATION STRATEGY

Some of the Interventions have the possibility of being funded through the budgets of the departments that primarily use them (Water Department at the Waterworks, License Commission at the Lombardi Building, Cable TV for their equipment at the Sullivan Chamber). The balance of the spaces are used by multiple departments and more extensively by the public. Funding for the capital costs required by the remaining spaces will be appropriated at the City's discretion.

High total project costs resulting from both the complexity of the program as well as the quantity of spaces involved requires either value engineering or phasing in order to achieve the stated goals for all Interventions. Value engineering will be a challenging process given the importance of consistency across the various spaces, and while efforts will be taken to remove excess project costs, it will be unlikely to produce dramatic savings. As a result, prioritizing and phasing the completion of the work is seen as the primary method by which project expenditures can be controlled.

B. PHASING OPTIONS & ESTIMATED COSTS

In order to achieve the project's objective of continuity and consistency of user interface across the spaces while managing the overall cost of the project, multiple scenarios and priorities were considered. Ultimately, it was determined that the best option to balance both goals would be to create a contract for the AV scope at all spaces, and contracts for all other aspects of scope could be broken down individually or in groups as funds become available. Work in the AV Scope contract would be completed concurrently with the other work in each of the rooms as it is performed, but the unifying contract will enforce the continuity between spaces that is so essential to the success of the project.

The summary page of the preliminary cost estimate is provided on the facing page. This summary breaks out the cost of each intervention, project totals and describes the AV costs independent of the associated construction costs at the far right. Total project costs as currently defined are estimated to be \$1,357,919 before contingencies. AV scope costs (\$594,680 before contingencies) represent a little less than half of the total project costs, which is to be expected, given its prominence in each intervention. Depending on the ultimate phasing of the various Interventions, individual project costs will be the sum of the AV and non-AV costs for each of the spaces in the contract.

C. PHASING SCHEDULE

Scheduling of the work will be dependent on the prioritization of the Intervention as mentioned within each section of this report, as well as the activity level of each space at various times of the year. The Sullivan Chamber, for example, is the highest priority space but is also among the most used in the project throughout the calendar year. The majority of the work could potentially be completed during the August recess, which would minimize the time that meetings and hearings would need to be shifted. Other spaces are far more flexible, both in terms of activity level and the ability to shift events to other spaces. With some advance notice and scheduling, it should be possible to close the rooms for whatever duration is necessary to complete the recommended work.

August 28, 2013													
CITY OF CAMBRIDGE Cambridge, MA AV Upgrades													
Architect : LDa Architects, LLP													
Total Project Estimate													
		City Hall Annex	Ackermann Room	Anastos Sophie Room	Senior Center	Sullivan Chamber	Water Department	Lombardi Building	Portable AV	Non AV Only	AV Only	Grand Total	% of ECC
Total Program Area													
A	Substructure	-	-	-	-	-	-	-	-	-	-	-	0.00%
B	Shell	-	-	500	-	-	-	-	-	500	-	500	0.04%
C	Interiors	9,000	39,840	5,900	51,500	90,100	80,600	5,000	-	281,940	-	281,940	20.76%
D	Services (not included below)												
D10	Conveying	-	-	-	-	-	-	-	-	-	-	-	0.00%
D20	Plumbing	-	-	-	-	-	-	-	-	-	-	-	0.00%
D30	HVAC	7,500	9,500	11,500	38,000	10,000	-	17,000	-	93,500	-	93,500	6.89%
D40	Fire Protection	-	-	-	-	-	-	-	-	-	-	-	0.00%
D50	Electrical		18,540	9,180	41,010	58,260		7,520		134,510		134,510	9.91%
	AV	35,950	44,744	30,755	74,620	316,011	19,741	20,143	43,657		585,621	585,621	43.13%
E	Fittings and Fixed Equipment	-	3,200	-	-	-	-	-	-	3,200	-	3,200	0.24%
F	Special Construction & Demolition	800	3,000	1,000	8,000	8,000	1,500	3,000	-	25,300	-	25,300	1.86%
	Building Total	\$53,250	\$118,824	\$58,835	\$213,130	\$482,371	\$101,841	\$52,663	\$ 43,657	\$ 538,950	\$ 585,621	\$ 1,124,571	
Z	General Requirements, General Conditions, Insurance, Bond & Permit	7,988	17,824	8,825	31,970	72,356	15,276	7,899	6,549	162,137	6,549	168,686	15.00%
	General Contractor's Overhead & Profit	3,062	6,832	3,383	12,255	27,736	5,856	3,028	2,510	62,153	2,510	64,663	5.00%
	Subtotal ECC Before Contingencies	\$64,299	\$143,480	\$71,043	\$257,354	\$582,463	\$122,973	\$63,591	\$ 52,716	\$ 763,240	\$ 594,680	\$ 1,357,919	
	Contingencies												
	Design Contingency	9,645	21,522	10,656	38,603	87,369	18,446	9,539	7,907	195,781	7,907	203,688	15.00%
	Construction Contingency												
	Off hour work	7,394	16,500	8,170	29,596	66,983	14,142	7,313	6,062	150,098	6,062	156,161	10.00%
	Escalation Contingency	2,588	5,775	2,859	10,359	23,444	4,950	2,560	2,122	52,534	2,122	54,656	3.50%
	Total ECC with Contingencies	\$83,927	\$187,277	\$92,729	\$335,912	\$760,260	\$160,511	\$83,002	\$ 68,807	\$ 1,161,653	\$ 610,771	\$1,772,424	

Fig. 3A - Preliminary cost estimate: Summary Page
(full estimate located in Appendix A)

APPENDIX A: REFERENCE DOCUMENTS

CITY OF CAMBRIDGE
Cambridge, MA

AV Upgrades

August 08, 2013

Architect : LDa Architects, LLP



60 Dedham Avenue, Needham, Massachusetts



CITY OF CAMBRIDGE
Cambridge, MA

AV Upgrades
ESTIMATE QUALIFICATIONS

- 1 Pricing is based on the Review of Audiovisual Renovations drawings provided by LDa Architects LLP.
Received March 11, 2013
We have priced for the work to be carried out during normal hours between 7 AM and 3 PM. However, see
- 2 allowance for off hour work below.
- 3 Prevailing wage labor rates are included.
- 4 Testing, removal and disposal of hazardous materials are excluded.
- 5 Maintaining, repairing and reworking the existing façade is not part of the scope of work.
- 6 A/E fees are excluded.
- 7 There are no phasing requirements allowed for in the estimate
- 8 General Requirements & General Conditions is included at: 15.00%
- 9 Contractor's Overhead & Profit is included at: 5.00%
- 10 Design contingency is included at: 15.00%
- 11 Off hour work is included 10.00%
- 12 Escalation contingency is included at: 3.50%
- 13 Construction contingency is excluded

August 08, 2013

CITY OF CAMBRIDGE
Cambridge, MA
AV ONLY

Architect : LDa Architects, LLP

Total Project Estimate

Program Area	Sullivan Chamber Est. Cost	Ackermann Room Est. Cost	Sophie Anastos Room Est. Cost	Senior Center Est. Cost	City Hall Annex Est. Cost	Water Department Est. Cost	Lombardi Building Est. Cost	Portable AV Work Est. Cost	Grand Total	% of ECC
A Substructure	-	-	-	-	-	-	-	-	-	0.00%
B Shell	-	-	-	-	-	-	-	-	-	0.00%
C Interiors	-	-	-	-	-	-	-	-	-	0.00%
D Services (not included below)	-	-	-	-	-	-	-	-	-	0.00%
D10 Conveying	-	-	-	-	-	-	-	-	-	0.00%
D20 Plumbing	-	-	-	-	-	-	-	-	-	0.00%
D30 HVAC	-	-	-	-	-	-	-	-	-	0.00%
D40 Fire Protection	-	-	-	-	-	-	-	-	-	0.00%
D50 Audio Video	316,011	44,744	30,755	74,620	35,950	19,741	20,143	43,657	585,621	82.60%
E Fittings and Fixed Equipment	-	-	-	-	-	-	-	-	-	0.00%
F Special Construction & Demolition	-	-	-	-	-	-	-	-	-	0.00%
Building Total	\$316,011	\$44,744	\$30,755	\$74,620	\$35,950	\$19,741	\$20,143	\$43,657	\$585,621	
Z										
General Requirements, General Conditions, Insurance, Bond & Permit	47,402	6,712	4,613	11,193	5,393	2,961	3,021	6,549	87,843	15.00%
General Contractor's Overhead & Profit	18,171	2,573	1,768	4,291	2,067	1,135	1,158	2,510	35,493	5.00%
Subtotal ECC Before Contingencies	\$381,583	\$54,028	\$37,137	\$90,104	\$43,410	\$23,837	\$24,323	\$52,716	\$708,958	
Contingencies										
Design Contingency	57,237	8,104	5,570	13,516	6,511	3,576	3,648	7,907	106,071	15.00%
Construction Contingency	0	-	0	-	0	-	0	-	-	
Off hour work	43,882	6,213	4,271	10,362	4,992	2,741	2,797	6,062	81,321	10.00%
Escalation Contingency	16,895	2,392	1,644	3,989	1,922	1,055	1,077	2,334	31,309	3.50%
Total ECC with Contingencies	\$499,597	\$70,738	\$48,622	\$117,970	\$56,835	\$31,210	\$31,845	\$69,020	\$927,658	
Total Rate/SF with Contingencies										

August 08, 2013

CITY OF CAMBRIDGE
Cambridge, MA
AV Upgrades

Architect : LDa Architects, LLP

Total Project Estimate									
Total Program Area	Sullivan Chamber Est. Cost	Ackermann Room Est. Cost	Sophie Anastos Room Est. Cost	Senior Center Est. Cost	City Hall Annex Est. Cost	Water Department Est. Cost	Lombardi Building Est. Cost	Grand Total	% of ECC
A Substructure	-	-	-	-	-	-	-	-	0.00%
B Shell	-	-	500	-	-	-	-	500	0.08%
C Interiors	90,100	39,840	5,900	51,500	9,000	80,600	5,000	281,940	43.32%
D Services (not included below)	-	-	-	-	-	-	-	-	0.00%
D10 Conveying	-	-	-	-	-	-	-	-	0.00%
D20 Plumbing	10,000	9,500	11,500	38,000	7,500	-	17,000	93,500	14.37%
D30 HVAC	-	-	-	-	-	-	-	-	0.00%
D40 Fire Protection	58,260	18,540	9,180	41,010	-	-	7,520	134,510	20.67%
D50 Electrical	-	3,200	-	-	-	-	-	3,200	0.49%
E Fittings and Fixed Equipment	8,000	3,000	1,000	8,000	800	1,500	3,000	25,300	3.89%
F Special Construction & Demolition	\$166,360	\$74,080	\$28,080	\$138,510	\$17,300	\$82,100	\$32,520	\$538,950	
Building Total									
Z	24,954	11,112	4,212	20,777	2,595	12,315	4,878	80,843	15.00%
General Requirements, General Conditions, Insurance, Bond & Permit	9,566	4,260	1,615	7,964	995	4,721	1,870	30,990	5.00%
General Contractor's Overhead & Profit	\$200,880	\$89,452	\$33,907	\$167,251	\$20,890	\$99,136	\$39,268	\$650,782	
Subtotal ECC Before Contingencies									
Contingencies									
Design Contingency	30,132	13,418	5,086	25,088	3,133	14,870	5,890	97,617	15.00%
Construction Contingency									
Off hour work	23,101	10,287	3,899	19,234	2,402	11,401	4,516	74,840	10.00%
Escalation Contingency	8,085	3,600	1,365	6,732	841	3,990	1,581	26,194	3.50%
Total ECC with Contingencies	\$262,198	\$116,757	\$44,257	\$218,304	\$27,266	\$129,397	\$51,254	\$849,433	
Total Rate/SF with Contingencies									

August 08, 2013

CITY OF CAMBRIDGE
Cambridge, MA
AV Upgrades

Architect : LDa Architects, LLP

Sullivan Chamber

SUMMARY

	Total Program Area	GFA	Raw Rate/SF (excl all markups)	Elements Subtotal	Est. Cost	% of ECC	Notes
A	Substructure				\$0	0.00%	NIC
A10	Foundations			\$0			NIC
	A1010 Standard Foundations			0			NIC
	A1020 Special Foundations			0			NIC
	A1030 Slab on Grade			0			NIC
A20	Basement Construction			\$0			NIC
	A2010 Basement Excavation			0			NIC
	A2020 Basement Walls			0			NIC
B	Shell				\$0	0.00%	NIC
B10	Superstructure			\$0			NIC
	B1010 Floor Construction			0			NIC
	B1020 Roof Construction			0			NIC
B20	Exterior Enclosure			\$0			NIC
	B2010 Exterior Walls			0			NIC
	B2020 Exterior Windows			0			NIC
	B2030 Exterior Doors			0			NIC
B30	Roofing			\$0			NIC
	B3010 Roof Coverings			0			NIC
	B3020 Roof Openings			0			NIC
C	Interiors				\$90,100	44.85%	
C10	Interior Construction			\$5,100			
	C1010 Partitions			0			NIC
	C1020 Interior Doors			5,100			
	C1030 Fittings			0			NIC
C20	Stairs			\$0			NIC
	C2010 Stair Construction			0			NIC
	C2020 Stair Finishes			0			NIC
C30	Interior Finishes			\$85,000			
	C3010 Wall Finishes			20,600			
	C3020 Floor Finishes			0			NIC
	C3030 Ceiling Finishes			64,400			
D	Services						
D10	Conveying			\$0	\$0	0.00%	NIC
	D1010 Elevators and Lifts			0			NIC
	D1020 Escalators and Moving Walks			0			NIC
	D1090 Other Conveying Systems			0			NIC
D20	Plumbing			\$0	\$0	0.00%	NIC
	D2010 Plumbing Fixtures			0			NIC
	D2020 Domestic Water Distribution			0			NIC
	D2030 Sanitary Waste			0			NIC
	D2040 Rain Water Drainage			0			NIC
	D2090 Other Plumbing Services			0			NIC
D30	HVAC			\$10,000	\$10,000	4.98%	
	D3010 Energy Supply			0			NIC
	D3020 Heat Generating Systems			10,000			
	D3030 Cooling Generating Systems			0			NIC
	D3040 Distribution Systems			0			NIC
	D3050 Terminal and Package Units			0			NIC
	D3060 Controls and Instrumentation			0			NIC
	D3070 Systems Testing and Balancing			0			NIC
	D3090 Other HVAC Systems and Equipment			0			NIC
D40	Fire Protection			\$0	\$0	0.00%	NIC
	D4010 Sprinklers			0			NIC
	D4020 Standpipes			0			NIC
	D4030 Fire Protection Specialties			0			NIC

August 08, 2013

CITY OF CAMBRIDGE
Cambridge, MA
AV Upgrades

Architect : LDa Architects, LLP

Sullivan Chamber

SUMMARY

	Total Program Area	GFA	Raw Rate/SF (excl all markups)	Elements Subtotal	Est. Cost	% of ECC	Notes
	D4090 Other Fire Protection Systems			0			NIC
D50	Electrical			\$58,260	\$58,260	29.00%	
	D5010 Electrical Service and Distribution			0			NIC
	D5020 Lighting and Branch Wiring			58,260			
	D5030 Communications and Security			In AV			
	D5090 Other Electrical Systems			0			NIC
E	Equipment and Furnishings				\$0	0.00%	NIC
E10	Equipment				\$0		NIC
	E1010 Commerical Equipment			0			NIC
	E1020 Institutional Equipment			0			NIC
	E1030 Vehicular Equipment			0			NIC
	E1090 Other Equipment			0			NIC
E20	Furnishings				\$0		NIC
	E2010 Fixed Furnishings			0			NIC
	E2020 Movable Furnishings			0			NIC
F	Special Construction & Demolition				\$8,000	3.98%	NIC
F10	Special Construction				\$0		NIC
	F1010 Special Structures			0			NIC
	F1020 Integrated Construction			0			NIC
	F1030 Vehicular Equipment			0			NIC
	F1040 Special Facilities			0			NIC
	F1050 Special Controls and Instrumentation			0			NIC
F20	Selective Building Demolition				\$8,000		
	F2010 Building Elements Demolition			8,000			
	F2020 Hazardous Components Abatement			0			NIC
	Building Total				\$166,360		
Z	General Requirements, General Conditions, Insurance, Bond, & Permit				24,954	15.00%	
	Contractor's Overhead & Profit				9,566	5.00%	
	Subtotal ECC Before Contingencies				\$200,880		
	Contingencies						
	Design Contingency				30,132	15.00%	
	Construction Contingency						Excluded
	Off hour work				23,101	10.00%	
	Escalation Contingency				8,085	3.50%	
	Total ECC with contingencies				\$262,198		
	<i>Total Rate/SF with contingencies</i>						

August 08, 2013

CITY OF CAMBRIDGE
 Cambridge, MA
 AV Upgrades

Architect : LDa Architects, LLP

Sullivan Chamber

Code	Description	Quantity	Unit	Rate	Assembly Cost
A	SUBSTRUCTURE				
A10	FOUNDATIONS				
A1010	Standard Foundations				\$ -
	No items in this section				
A1020	Special Foundations				\$ -
	No items in this section				
A1030	Slab on Grade				\$ -
	No items in this section				
A20	BASEMENT CONSTRUCTION				
A2010	Basement Excavation				\$ -
	No items in this section				
A2020	Basement Walls				\$ -
	No items in this section				
B	SHELL				
B10	SUPERSTRUCTURE				
B1010	Floor Construction				\$ -
	No items in this section				
B1020	Roof Construction				\$ -
B20	ENCLOSURE				
B2010	Exterior Walls				\$ -
	No items in this section				
B2020	Exterior Windows				\$ -
	No items in this section				
B2030	Exterior Doors				\$ -
	No items in this section				
B30	ROOFING				
B3010	Roof Coverings				\$ -
	No items in this section				
B3020	Roof Openings				\$ -
	No items in this section				

August 08, 2013

CITY OF CAMBRIDGE
 Cambridge, MA
 AV Upgrades

Architect : LDa Architects, LLP

Sullivan Chamber

C	INTERIORS				
C10	INTERIOR CONSTRUCTION				
C1010	Partitions				\$ -
	No items in this section				
C1020	Interior Doors				\$ 5,100
	Gaskets to doors	9	EA	\$ 300.00	2,700
	Auto door bottoms & thresholds	1	LS	\$ 2,400.00	2,400
C1030	Fittings				\$ -
	No items in this section				
C20	STAIRS				
C2010	Stair Construction				\$ -
	No items in this section				
C2020	Stair Finishes				\$ -
	No items in this section				
C30	INTERIOR FINISHES				
C3010	Wall Finishes				\$ 20,600
	Velour curtain, retractable	1	LS	\$ 15,000.00	15,000
	Acoustical panels	160	SF	\$ 35.00	5,600
C3020	Floor Finishes				\$ -
	Replace existing carpet		SY	\$ 55.00	
C3030	Ceiling Finishes				\$ 64,400
	ACT panel	1	LS	\$ 9,400.00	9,400
	Acoustical plaster	1	LS	\$ 35,000.00	35,000
	Staging for plaster work	1	LS	\$ 20,000.00	20,000
D	SERVICES				
D10	CONVEYING				
D1010	Elevators and Lifts				\$ -
	No items in this section				
D1020	Escalators and Moving Walks				\$ -
	No items in this section				

August 08, 2013

CITY OF CAMBRIDGE
 Cambridge, MA
 AV Upgrades

Architect : LDa Architects, LLP

Sullivan Chamber

D1090	Other Conveying Systems					\$ -
	No items in this section					
D20	PLUMBING					
D2010	Plumbing Fixtures					\$ -
	No items in this section					
D2020	Domestic Water Distribution					\$ -
	No items in this section					
D2030	Sanitary Waste					\$ -
	No items in this section					
D2040	Rain Water Drainage					\$ -
	No items in this section					
D2090	Other Plumbing Systems					\$ -
	No items in this section					
D30	HVAC					
D3010	Energy Supply					\$ -
	No items in this section					
D3020	Heat Generating Systems					\$ 10,000
	Allowance for modification to existing	1	LS	\$ 10,000.00		10,000
D3030	Cooling Generating Systems					\$ -
	Allowance for modification to existing					
D3040	Distribution Systems					\$ -
	Allowance					
D3050	Terminal and Package Units					\$ -
	No items in this section					
D3060	Controls and Instrumentation					\$ -
	Allowance for modification to existing					
D3070	Systems Testing and Balancing					\$ -
	Allowance					
D3090	Other HVAC Systems and Equipment					\$ -
	No items in this section					

August 08, 2013

CITY OF CAMBRIDGE
 Cambridge, MA
 AV Upgrades

Architect : LDa Architects, LLP

Sullivan Chamber

D40	FIRE PROTECTION					
D4010	Sprinklers					\$ -
	Allowance to reset heads					
D4020	Standpipes					\$ -
	No items in this section					
D4030	Fire Protection Specialties					\$ -
	No items in this section					
D4090	Other Fire Protection Systems					\$ -
	No items in this section					
D50	ELECTRICAL					
D5010	Electrical Service and Distribution					\$ -
	No items in this section					
D5020	Lighting and Branch Wiring					\$ 58,260
	Light fixtures					
	type L1	181	LF	\$ 110.00		19,910
	type L2	17	EA	\$ 200.00		3,400
	type P1 (relamping only)	1	EA	\$ 125.00		125
	type P2 (relamping only)	4	EA	\$ 125.00		500
	type R1	17	EA	\$ 325.00		5,525
	type R2	14	EA	\$ 350.00		4,900
	type R3	4	EA	\$ 360.00		1,440
	type W1	10	EA	\$ 340.00		3,400
	type W2	4	EA	\$ 345.00		1,380
	3/4" EMT (w 3#12)	1,050	LF	\$ 10.00		10,500
	Switches w/ MC Cables	8	EA	\$ 110.00		880
	New dimming control (C)	2	EA	\$ 650.00		1,300
	Power to AV equipment	1	LS	\$ 5,000.00		5,000
D5030	Communications and Security					\$ 316,011
	Electric Projection Screen	1	EA	\$ 16,000.00		16,000
	Video Projector	1	EA	\$ 15,000.00		15,000
	Room Computers (OFE)					
	Dais Monitors	2	EA	\$ 500.00		1,000
	Gallery Flat Panel Displays	2	EA	\$ 4,000.00		8,000
	Document Camera	1	EA	\$ 3,800.00		3,800
	Blu-ray DVD Player	1	EA	\$ 200.00		200
	Digital/Analog Connections	1	EA	\$ 6,300.00		6,300
	Castered Equipment Rack	1	EA	\$ 1,200.00		1,200
	Pan/Tilt Video Cameras	4	EA	\$ 9,000.00		36,000

August 08, 2013

CITY OF CAMBRIDGE
 Cambridge, MA
 AV Upgrades

Architect : LDa Architects, LLP

Sullivan Chamber

	Video Camera	1	EA	\$ 4,700.00	4,700
	Digital Video Production Switcher	1	EA	\$ 13,000.00	13,000
	Pan/Tilt Camera Controller	1	EA	\$ 5,000.00	5,000
	Camera/Program/Preview Monitors	3	EA	\$ 4,200.00	12,600
	Waveform Monitor/Vector scope	1	EA	\$ 4,000.00	4,000
	High-Definition Video Recorder	1	EA	\$ 5,300.00	5,300
	Equipment Racks	3	EA	\$ 1,200.00	3,600
	Rich Media Recorder/Streamer (OPTION)	1	EA	\$ 15,000.00	15,000
	Steerable Column Loudspeakers	2	EA	\$ 14,000.00	28,000
	Gallery Loudspeakers	4	EA	\$ 150.00	600
	Audio Power Amplifier	1	EA	\$ 800.00	800
	Wireless Microphone Systems	3	EA	\$ 1,500.00	4,500
	Lectern Gooseneck Microphone	1	EA	\$ 350.00	350
	Digital Audio Signal Processor	1	EA	\$ 8,000.00	8,000
	Assistive Listening System	1	EA	\$ 2,000.00	2,000
	Video/Audio Routing Equipment	1	EA	\$ 12,000.00	12,000
	AV Control Touchscreen	2	EA	\$ 3,800.00	7,600
	Digital Video 2x1 Switch	1	EA	\$ 600.00	600
	Fiber Optic Transmission Equipment	2	EA	\$ 3,000.00	6,000
	Miscellaneous Hardware & Cable	1	EA	\$ 6,000.00	6,000
	Installation of above	1	EA	\$ 74,253.00	74,253
	Control System Programming	1	EA	\$ 10,608.00	10,608
	Power Requirement allowance	1	LS	\$ 1,500.00	1,500
	Empty Conduit & backboxes	1	LS	\$ 2,500.00	2,500
	D5090 Other Electrical Systems				\$ -
	No items in this section				
E	EQUIPMENT & FURNISHINGS				
E10	EQUIPMENT				
	E1010 Commercial Equipment				\$ -
	No items in this section				
	E1020 Institutional Equipment				\$ -
	No items in this section				
	E1030 Vehicular Equipment				\$ -
	No items in this section				
	E1090 Other Equipment				\$ -
	No items in this section				

August 08, 2013

CITY OF CAMBRIDGE
 Cambridge, MA
 AV Upgrades

Architect : LDa Architects, LLP

Sullivan Chamber

E20	FURNISHINGS					
E2010	Fixed Furnishings					\$ -
	Room darkening					
E2020	Movable Furnishings					\$ -
	No items in this section					
F	SPECIAL CONSTRUCTION & DEMOLITION					
F10	SPECIAL CONSTRUCTION					
F1010	Special Structures					\$ -
	No items in this section					
F1020	Integrated Construction					\$ -
	No items in this section					
F1030	Vehicular Equipment					\$ -
	No items in this section					
F1040	Special Facilities					\$ -
	No items in this section					
F1050	Special Controls and Instrumentation					\$ -
	No items in this section					
F20	SELECTIVE BUILDING DEMOLITION					
F2010	Building Elements Demolition					\$ 8,000
	Allowance	1	LS	\$ 8,000.00		8,000
	Remove existing carpet		SF	\$ 1.00		
F2020	Hazard Components Abatement					\$ -
	No items in this section					

August 08, 2013

CITY OF CAMBRIDGE
Cambridge, MA
AV Upgrades

Architect : LDa Architects, LLP

Ackermann Room

SUMMARY

Total Program Area		GFA	Raw Rate/SF (excl all markups)	Elements Subtotal	Est. Cost	% of ECC	Notes
A	Substructure				\$0	0.00%	NIC
A10	Foundations			\$0			NIC
	A1010 Standard Foundations			0			NIC
	A1020 Special Foundations			0			NIC
	A1030 Slab on Grade			0			NIC
A20	Basement Construction			\$0			NIC
	A2010 Basement Excavation			0			NIC
	A2020 Basement Walls			0			NIC
B	Shell				\$0	0.00%	NIC
B10	Superstructure			\$0			NIC
	B1010 Floor Construction			0			NIC
	B1020 Roof Construction			0			NIC
B20	Exterior Enclosure			\$0			NIC
	B2010 Exterior Walls			0			NIC
	B2020 Exterior Windows			0			NIC
	B2030 Exterior Doors			0			NIC
B30	Roofing			\$0			NIC
	B3010 Roof Coverings			0			NIC
	B3020 Roof Openings			0			NIC
C	Interiors				\$39,840	44.54%	
C10	Interior Construction			\$4,000			
	C1010 Partitions			0			NIC
	C1020 Interior Doors			1,200			
	C1030 Fittings			2,800			
C20	Stairs			\$0			NIC
	C2010 Stair Construction			0			NIC
	C2020 Stair Finishes			0			NIC
C30	Interior Finishes			\$35,840			
	C3010 Wall Finishes			32,000			
	C3020 Floor Finishes			1,200			
	C3030 Ceiling Finishes			2,640			
D	Services						
D10	Conveying			\$0	\$0	0.00%	NIC
	D1010 Elevators and Lifts			0			NIC
	D1020 Escalators and Moving Walks			0			NIC
	D1090 Other Conveying Systems			0			NIC
D20	Plumbing			\$0	\$0	0.00%	NIC
	D2010 Plumbing Fixtures			0			NIC
	D2020 Domestic Water Distribution			0			NIC
	D2030 Sanitary Waste			0			NIC
	D2040 Rain Water Drainage			0			NIC
	D2090 Other Plumbing Services			0			NIC
D30	HVAC			\$9,500	\$9,500	10.62%	
	D3010 Energy Supply			0			NIC
	D3020 Heat Generating Systems			0			NIC
	D3030 Cooling Generating Systems			8,000			
	D3040 Distribution Systems			0			NIC
	D3050 Terminal and Package Units			0			NIC
	D3060 Controls and Instrumentation			0			NIC
	D3070 Systems Testing and Balancing			1,500			
	D3090 Other HVAC Systems and Equipment			0			NIC
D40	Fire Protection			\$0	\$0	0.00%	NIC
	D4010 Sprinklers			0			NIC
	D4020 Standpipes			0			NIC
	D4030 Fire Protection Specialties			0			NIC
	D4090 Other Fire Protection Systems			0			NIC
D50	Electrical			\$18,540	\$18,540	20.73%	
	D5010 Electrical Service and Distribution			0			NIC

August 08, 2013

CITY OF CAMBRIDGE
Cambridge, MA
AV Upgrades

Architect : LDa Architects, LLP

Ackermann Room

SUMMARY

Total Program Area		GFA	Raw Rate/SF (excl all markups)	Elements Subtotal	Est. Cost	% of ECC	Notes
	D5020			18,540			
	D5030			In AV			
	D5090			0			NIC
E	Equipment and Furnishings				\$3,200	3.58%	NIC
E10	Equipment			\$0			NIC
	E1010			0			NIC
	E1020			0			NIC
	E1030			0			NIC
	E1090			0			NIC
E20	Furnishings			\$3,200			
	E2010			3,200			
	E2020			0			NIC
F	Special Construction & Demolition				\$3,000	3.35%	NIC
F10	Special Construction			\$0			NIC
	F1010			0			NIC
	F1020			0			NIC
	F1030			0			NIC
	F1040			0			NIC
	F1050			0			NIC
F20	Selective Building Demolition			\$3,000			
	F2010			3,000			
	F2020			0			NIC
	Building Total				\$74,080		
Z	General Requirements, General Conditions, Insurance, Bond, & Permit				11,112	15.00%	
	Contractor's Overhead & Profit				4,260	5.00%	
	Subtotal ECC Before Contingencies				\$89,452		
	Contingencies						
	Design Contingency				13,418	15.00%	
	Construction Contingency						Excluded
	Off hour work				10,287	10.00%	
	Escalation Contingency				3,600	3.50%	
	Total ECC with contingencies				\$116,757		
	Total Rate/SF with contingencies						

August 08, 2013

CITY OF CAMBRIDGE
 Cambridge, MA
 AV Upgrades

Architect : LDa Architects, LLP

Ackermann Room

Code	Description	Quantity	Unit	Rate	Assembly Cost
A	SUBSTRUCTURE				
A10	FOUNDATIONS				
A1010	Standard Foundations				\$ -
	No items in this section				
A1020	Special Foundations				\$ -
	No items in this section				
A1030	Slab on Grade				\$ -
	No items in this section				
A20	BASEMENT CONSTRUCTION				
A2010	Basement Excavation				\$ -
	No items in this section				
A2020	Basement Walls				\$ -
	No items in this section				
B	SHELL				
B10	SUPERSTRUCTURE				
B1010	Floor Construction				\$ -
	No items in this section				
B1020	Roof Construction				\$ -
	No items in this section				
B20	ENCLOSURE				
B2010	Exterior Walls				\$ -
	No items in this section				
B2020	Exterior Windows				\$ -
	No items in this section				
B2030	Exterior Doors				\$ -
	No items in this section				
B30	ROOFING				
B3010	Roof Coverings				\$ -
	No items in this section				
B3020	Roof Openings				\$ -
	No items in this section				

CITY OF CAMBRIDGE
 Cambridge, MA
 AV Upgrades

Architect : LDa Architects, LLP

Ackermann Room

C	INTERIORS				
C10	INTERIOR CONSTRUCTION				
C1010	Partitions				\$ -
	No items in this section				
C1020	Interior Doors				\$ 1,200
	Gaskets to doors	2	EA	\$ 300.00	600
	Auto door bottoms & thresholds	1	LS	\$ 600.00	600
C1030	Fittings				\$ 2,800
	Window treatment	80	SF	\$ 35.00	2,800
C20	STAIRS				
C2010	Stair Construction				\$ -
	No items in this section				
C2020	Stair Finishes				\$ -
	No items in this section				
C30	INTERIOR FINISHES				
C3010	Wall Finishes				\$ 32,000
	Patch or repair to existing - 50% allowance - carefully remove existing wood panel for reinstall later	400	SF	\$ 80.00	32,000
	Refinish existing wood panel	400	SF	\$ 15.00	6,000
C3020	Floor Finishes				\$ 1,200
	Carpet	400	SF	\$ 3.00	1,200
C3030	Ceiling Finishes				\$ 2,640
	ACT	440	SF	\$ 6.00	2,640
D	SERVICES				
D10	CONVEYING				
D1010	Elevators and Lifts				\$ -
	No items in this section				
D1020	Escalators and Moving Walks				\$ -
	No items in this section				
D1090	Other Conveying Systems				\$ -
	No items in this section				

August 08, 2013

CITY OF CAMBRIDGE
 Cambridge, MA
 AV Upgrades

Architect : LDa Architects, LLP

Ackermann Room

D20	PLUMBING				
D2010	Plumbing Fixtures				\$ -
	No items in this section				
D2020	Domestic Water Distribution				\$ -
	No items in this section				
D2030	Sanitary Waste				\$ -
	No items in this section				
D2040	Rain Water Drainage				\$ -
	No items in this section				
D2090	Other Plumbing Systems				\$ -
	No items in this section				
D30	HVAC				
D3010	Energy Supply				\$ -
	No items in this section				
D3020	Heat Generating Systems				\$ -
	No items in this section				
D3030	Cooling Generating Systems				\$ 8,000
	New split AC system	1	LS	\$ 8,000.00	8,000
D3040	Distribution Systems				\$ -
	No items in this section				
D3050	Terminal and Package Units				\$ -
	No items in this section				
D3060	Controls and Instrumentation				\$ -
	No items in this section				
D3070	Systems Testing and Balancing				\$ 1,500
	Allowance	1	LS	\$ 1,500.00	1,500
D3090	Other HVAC Systems and Equipment				\$ -
	No items in this section				
D40	FIRE PROTECTION				
D4010	Sprinklers				\$ -
	Allowance to reset heads				

August 08, 2013

CITY OF CAMBRIDGE
 Cambridge, MA
 AV Upgrades

Architect : LDa Architects, LLP

Ackermann Room

D4020	Standpipes					\$ -
	No items in this section					
D4030	Fire Protection Specialties					\$ -
	No items in this section					
D4090	Other Fire Protection Systems					\$ -
	No items in this section					
D50	ELECTRICAL					
D5010	Electrical Service and Distribution					\$ -
	No items in this section					
D5020	Lighting and Branch Wiring					\$ 18,540
	Lighting fixtures					
	type T-1	20	EA	\$ 250.00		5,000
	type P-3 (relamping only)	4	EA	\$ 125.00		500
	type TA	60	LF	\$ 100.00		6,000
	3/4" EMT (w 3#12)	360	LF	\$ 10.00		3,600
	Switches w/ MC Cables	4	EA	\$ 110.00		440
	Power to equipment	1	LS	\$ 3,000.00		3,000
D5030	Communications and Security					\$ 44,744
	70" LCD Display	1	EA	\$ 11,000.00		11,000
	Video/Audio Transmission Equipment:	1	EA	\$ 3,900.00		3,900
	Table Box	1	EA	\$ 700.00		700
	Audio Conference Phone	1	EA	\$ 1,500.00		1,500
	Videoconference Codec	1	EA	\$ 6,500.00		6,500
	Loudspeaker System	1	EA	\$ 900.00		900
	AV Control System	1	EA	\$ 1,200.00		1,200
	Credenza	1	EA	\$ 4,500.00		4,500
	Miscellaneous Hardware & Cable	1	EA	\$ 1,000.00		1,000
	Installation	1	EA	\$ 10,920.00		10,920
	Control System Programming	1	EA	\$ 624.00		624
	Power Requirement allowance	1	LS	\$ 750.00		750
	Empty Conduit & backboxes	1	LS	\$ 1,250.00		1,250
D5090	Other Electrical Systems					\$ -
	No items in this section					
E	EQUIPMENT & FURNISHINGS					
E10	EQUIPMENT					
E1010	Commercial Equipment					\$ -
	No items in this section					

August 08, 2013

CITY OF CAMBRIDGE
 Cambridge, MA
 AV Upgrades

Architect : LDa Architects, LLP

Ackermann Room

E1020	Institutional Equipment					\$ -
	No items in this section					
E1030	Vehicular Equipment					\$ -
	No items in this section					
E1090	Other Equipment					\$ -
	No items in this section					
E20	FURNISHINGS					
E2010	Fixed Furnishings					\$ 3,200
	Room darkening	80	SF	\$ 40.00		3,200
E2020	Movable Furnishings					\$ -
	No items in this section					
F	SPECIAL CONSTRUCTION & DEMOLITION					
F10	SPECIAL CONSTRUCTION					
F1010	Special Structures					\$ -
	No items in this section					
F1020	Integrated Construction					\$ -
	No items in this section					
F1030	Vehicular Equipment					\$ -
	No items in this section					
F1040	Special Facilities					\$ -
	No items in this section					
F1050	Special Controls and Instrumentation					\$ -
	No items in this section					
F20	SELECTIVE BUILDING DEMOLITION					
F2010	Building Elements Demolition					\$ 3,000
	Allowance	1	LS	\$ 3,000.00		3,000
F2020	Hazard Components Abatement					\$ -
	No items in this section					

August 08, 2013

CITY OF CAMBRIDGE
Cambridge, MA
AV Upgrades

Architect : LDa Architects, LLP

Sophie Anastos Room

SUMMARY

	Total Program Area	GFA	Raw Rate/SF (excl all markups)	Elements Subtotal	Est. Cost	% of ECC	Notes
A	Substructure				\$0	0.00%	NIC
A10	Foundations			\$0			NIC
	A1010 Standard Foundations			0			NIC
	A1020 Special Foundations			0			NIC
	A1030 Slab on Grade			0			NIC
A20	Basement Construction			\$0			NIC
	A2010 Basement Excavation			0			NIC
	A2020 Basement Walls			0			NIC
B	Shell				\$500	1.47%	
B10	Superstructure			\$0			NIC
	B1010 Floor Construction			0			NIC
	B1020 Roof Construction			0			NIC
B20	Exterior Enclosure			\$500			
	B2010 Exterior Walls			0			NIC
	B2020 Exterior Windows			500			
	B2030 Exterior Doors			0			NIC
B30	Roofing			\$0			NIC
	B3010 Roof Coverings			0			NIC
	B3020 Roof Openings			0			NIC
C	Interiors				\$5,900	17.40%	
C10	Interior Construction			\$900			
	C1010 Partitions			0			NIC
	C1020 Interior Doors			900			
	C1030 Fittings			0			NIC
C20	Stairs			\$0			NIC
	C2010 Stair Construction			0			NIC
	C2020 Stair Finishes			0			NIC
C30	Interior Finishes			\$5,000			
	C3010 Wall Finishes			5,000			
	C3020 Floor Finishes			0			NIC
	C3030 Ceiling Finishes			0			NIC
D	Services						
D10	Conveying			\$0	\$0	0.00%	NIC
	D1010 Elevators and Lifts			0			NIC
	D1020 Escalators and Moving Walks			0			NIC
	D1090 Other Conveying Systems			0			NIC
D20	Plumbing			\$0	\$0	0.00%	NIC
	D2010 Plumbing Fixtures			0			NIC
	D2020 Domestic Water Distribution			0			NIC
	D2030 Sanitary Waste			0			NIC
	D2040 Rain Water Drainage			0			NIC
	D2090 Other Plumbing Services			0			NIC
D30	HVAC			\$11,500	\$11,500	33.92%	
	D3010 Energy Supply			0			NIC
	D3020 Heat Generating Systems			0			NIC
	D3030 Cooling Generating Systems			10,000			
	D3040 Distribution Systems			0			NIC
	D3050 Terminal and Package Units			0			NIC
	D3060 Controls and Instrumentation			1,500			
	D3070 Systems Testing and Balancing			0			NIC
	D3090 Other HVAC Systems and Equipment			0			NIC
D40	Fire Protection			\$0	\$0	0.00%	NIC
	D4010 Sprinklers			0			NIC
	D4020 Standpipes			0			NIC
	D4030 Fire Protection Specialties			0			NIC

August 08, 2013

CITY OF CAMBRIDGE
Cambridge, MA
AV Upgrades

Architect : LDa Architects, LLP

Sophie Anastos Room

SUMMARY

	Total Program Area	GFA	Raw Rate/SF (excl all markups)	Elements Subtotal	Est. Cost	% of ECC	Notes
	D4090 Other Fire Protection Systems			0			NIC
D50	Electrical			\$9,180	\$9,180	27.07%	
	D5010 Electrical Service and Distribution			0			NIC
	D5020 Lighting and Branch Wiring			9,180			
	D5030 Communications and Security			In AV			
	D5090 Other Electrical Systems			0			NIC
E	Equipment and Furnishings				\$0	0.00%	NIC
E10	Equipment			\$0			NIC
	E1010 Commerical Equipment			0			NIC
	E1020 Institutional Equipment			0			NIC
	E1030 Vehicular Equipment			0			NIC
	E1090 Other Equipment			0			NIC
E20	Furnishings			\$0			NIC
	E2010 Fixed Furnishings			0			NIC
	E2020 Movable Furnishings			0			NIC
F	Special Construction & Demolition				\$1,000	2.95%	NIC
F10	Special Construction			\$0			NIC
	F1010 Special Structures			0			NIC
	F1020 Integrated Construction			0			NIC
	F1030 Vehicular Equipment			0			NIC
	F1040 Special Facilities			0			NIC
	F1050 Special Controls and Instrumentation			0			NIC
F20	Selective Building Demolition			\$1,000			
	F2010 Building Elements Demolition			1,000			
	F2020 Hazardous Components Abatement			0			NIC
	Building Total				\$28,080		
Z	General Requirements, General Conditions, Insurance, Bond, & Permit				4,212	15.00%	
	Contractor's Overhead & Profit				1,615	5.00%	
	Subtotal ECC Before Contingencies				\$33,907		
	Contingencies						
	Design Contingency				5,086	15.00%	
	Construction Contingency						Excluded
	Off hour work				3,899	10.00%	
	Escalation Contingency				1,365	3.50%	
	Total ECC with contingencies				\$44,257		
	<i>Total Rate/SF with contingencies</i>						

August 08, 2013

CITY OF CAMBRIDGE
 Cambridge, MA
 AV Upgrades

Architect : LDa Architects, LLP

Sophie Anastos Room

Code	Description	Quantity	Unit	Rate	Assembly Cost
A	SUBSTRUCTURE				
A10	FOUNDATIONS				
A1010	Standard Foundations				\$ -
	No items in this section				
A1020	Special Foundations				\$ -
	No items in this section				
A1030	Slab on Grade				\$ -
	No items in this section				
A20	BASEMENT CONSTRUCTION				
A2010	Basement Excavation				\$ -
	No items in this section				
A2020	Basement Walls				\$ -
	No items in this section				
B	SHELL				
B10	SUPERSTRUCTURE				
B1010	Floor Construction				\$ -
	No items in this section				
B1020	Roof Construction				\$ -
	No items in this section				
B20	ENCLOSURE				
B2010	Exterior Walls				\$ -
	No items in this section				
B2020	Exterior Windows				\$ 500
	Repair existing window	1	LS	\$ 500.00	500
B2030	Exterior Doors				\$ -
	No items in this section				
B30	ROOFING				
B3010	Roof Coverings				\$ -
	No items in this section				

August 08, 2013

CITY OF CAMBRIDGE
 Cambridge, MA
 AV Upgrades

Architect : LDa Architects, LLP

Sophie Anastos Room

B3020	Roof Openings					\$ -
	No items in this section					
C	INTERIORS					
C10	INTERIOR CONSTRUCTION					
C1010	Partitions					\$ -
	No items in this section					
C1020	Interior Doors					\$ 900
	Gaskets to doors	1	EA	\$ 450.00		450
	Auto door bottoms & thresholds	1	LS	\$ 450.00		450
C1030	Fittings					\$ -
	No items in this section					
C20	STAIRS					
C2010	Stair Construction					\$ -
	No items in this section					
C2020	Stair Finishes					\$ -
	No items in this section					
C30	INTERIOR FINISHES					
C3010	Wall Finishes					\$ 5,000
	Allowance	1	LS	\$ 5,000.00		5,000
C3020	Floor Finishes					\$ -
	No items in this section					
C3030	Ceiling Finishes					\$ -
	No items in this section					
D	SERVICES					
D10	CONVEYING					
D1010	Elevators and Lifts					\$ -
	No items in this section					
D1020	Escalators and Moving Walks					\$ -
	No items in this section					
D1090	Other Conveying Systems					\$ -
	No items in this section					

August 08, 2013

CITY OF CAMBRIDGE
 Cambridge, MA
 AV Upgrades

Architect : LDa Architects, LLP

Sophie Anastos Room

D20	PLUMBING				
D2010	Plumbing Fixtures				\$ -
	No items in this section				
D2020	Domestic Water Distribution				\$ -
	No items in this section				
D2030	Sanitary Waste				\$ -
	No items in this section				
D2040	Rain Water Drainage				\$ -
	No items in this section				
D2090	Other Plumbing Systems				\$ -
	No items in this section				
D30	HVAC				
D3010	Energy Supply				\$ -
	No items in this section				
D3020	Heat Generating Systems				\$ -
	No items in this section				
D3030	Cooling Generating Systems				\$ 10,000
	New split AC system	1	LS	\$ 10,000.00	10,000
D3040	Distribution Systems				\$ -
	No items in this section				
D3050	Terminal and Package Units				\$ -
	No items in this section				
D3060	Controls and Instrumentation				\$ 1,500
	Allowance for modification to existing	1	LS	\$ 1,500.00	1,500
D3070	Systems Testing and Balancing				\$ -
	No items in this section				
D3090	Other HVAC Systems and Equipment				\$ -
	No items in this section				

August 08, 2013

CITY OF CAMBRIDGE
 Cambridge, MA
 AV Upgrades

Architect : LDa Architects, LLP

Sophie Anastos Room

D40	FIRE PROTECTION					
D4010	Sprinklers					\$ -
	No items in this section					
D4020	Standpipes					\$ -
	No items in this section					
D4030	Fire Protection Specialties					\$ -
	No items in this section					
D4090	Other Fire Protection Systems					\$ -
	No items in this section					
D50	ELECTRICAL					
D5010	Electrical Service and Distribution					\$ -
	No items in this section					
D5020	Lighting and Branch Wiring					\$ 9,180
	Light Fixtures					
	type P4 (relamping only)	2	EA	\$ 125.00		250
	type R4 (relamping only)	4	EA	\$ 125.00		500
	type R5 (relamping only)	8	EA	\$ 125.00		1,000
	3/4" EMT (w 3#12)	210	LF	\$ 10.00		2,100
	Switches w/ MC Cables	3	EA	\$ 110.00		330
	Power to equipment	1	LS	\$ 5,000.00		5,000
D5030	Communications and Security					\$ 30,755
	70" LCD Display	1	EA	\$ 11,000.00		11,000
	Video/Audio Transmission Equipment:	1	EA	\$ 3,900.00		3,900
	Audio Conference Phone	1	EA	\$ 1,500.00		1,500
	Loudspeaker System	1	EA	\$ 900.00		900
	AV Control System	1	EA	\$ 1,200.00		1,200
	Display Support System	1	EA	\$ 2,000.00		2,000
	Miscellaneous Hardware & Cable	1	EA	\$ 1,000.00		1,000
	Installation of above	1	EA	\$ 7,525.00		7,525
	Control System Programming	1	EA	\$ 430.00		430
	Power Requirement allowance	1	LS	\$ 450.00		450
	Empty Conduit & backboxes	1	LS	\$ 850.00		850
D5090	Other Electrical Systems					\$ -
	No items in this section					

August 08, 2013

CITY OF CAMBRIDGE
Cambridge, MA
AV Upgrades

Architect : LDa Architects, LLP

Sophie Anastos Room

E	EQUIPMENT & FURNISHINGS				
E10	EQUIPMENT				
E1010	Commercial Equipment				\$ -
	No items in this section				
E1020	Institutional Equipment				\$ -
	No items in this section				
E1030	Vehicular Equipment				\$ -
	No items in this section				
E1090	Other Equipment				\$ -
	No items in this section				
E20	FURNISHINGS				
E2010	Fixed Furnishings				\$ -
	No items in this section				
E2020	Movable Furnishings				\$ -
	No items in this section				
F	SPECIAL CONSTRUCTION & DEMOLITION				
F10	SPECIAL CONSTRUCTION				
F1010	Special Structures				\$ -
	No items in this section				
F1020	Integrated Construction				\$ -
	No items in this section				
F1030	Vehicular Equipment				\$ -
	No items in this section				
F1040	Special Facilities				\$ -
	No items in this section				
F1050	Special Controls and Instrumentation				\$ -
	No items in this section				
F20	SELECTIVE BUILDING DEMOLITION				
F2010	Building Elements Demolition				\$ 1,000
	Allowance	1	LS	\$ 1,000.00	1,000

August 08, 2013

CITY OF CAMBRIDGE
Cambridge, MA
AV Upgrades

Architect : LDa Architects, LLP

Sophie Anastos Room

F2020	Hazard Components Abatement				\$ -
	No items in this section				

August 08, 2013

CITY OF CAMBRIDGE
Cambridge, MA
AV Upgrades

Architect : LDa Architects, LLP

Senior Center
SUMMARY

	Total Program Area	GFA	Raw Rate/SF (excl all markups)	Elements Subtotal	Est. Cost	% of ECC	Notes
A	Substructure				\$0	0.00%	NIC
A10	Foundations			\$0			NIC
	A1010 Standard Foundations			0			NIC
	A1020 Special Foundations			0			NIC
	A1030 Slab on Grade			0			NIC
A20	Basement Construction			\$0			NIC
	A2010 Basement Excavation			0			NIC
	A2020 Basement Walls			0			NIC
B	Shell				\$0	0.00%	NIC
B10	Superstructure			\$0			NIC
	B1010 Floor Construction			0			NIC
	B1020 Roof Construction			0			NIC
B20	Exterior Enclosure			\$0			NIC
	B2010 Exterior Walls			0			NIC
	B2020 Exterior Windows			0			NIC
	B2030 Exterior Doors			0			NIC
B30	Roofing			\$0			NIC
	B3010 Roof Coverings			0			NIC
	B3020 Roof Openings			0			NIC
C	Interiors				\$51,500	30.79%	
C10	Interior Construction			\$34,500			
	C1010 Partitions			0			NIC
	C1020 Interior Doors			34,500			
	C1030 Fittings			0			NIC
C20	Stairs			\$0			NIC
	C2010 Stair Construction			0			NIC
	C2020 Stair Finishes			0			NIC
C30	Interior Finishes			\$17,000			
	C3010 Wall Finishes			10,000			
	C3020 Floor Finishes			7,000			
	C3030 Ceiling Finishes			0			NIC
D	Services						
D10	Conveying			\$0	\$0	0.00%	NIC
	D1010 Elevators and Lifts			0			NIC
	D1020 Escalators and Moving Walks			0			NIC
	D1090 Other Conveying Systems			0			NIC
D20	Plumbing			\$0	\$0	0.00%	NIC
	D2010 Plumbing Fixtures			0			NIC
	D2020 Domestic Water Distribution			0			NIC
	D2030 Sanitary Waste			0			NIC
	D2040 Rain Water Drainage			0			NIC
	D2090 Other Plumbing Services			0			NIC
D30	HVAC			\$38,000	\$38,000	22.72%	
	D3010 Energy Supply			0			NIC
	D3020 Heat Generating Systems			0			NIC
	D3030 Cooling Generating Systems			15,000			
	D3040 Distribution Systems			20,000			
	D3050 Terminal and Package Units			0			NIC
	D3060 Controls and Instrumentation			1,500			
	D3070 Systems Testing and Balancing			1,500			
	D3090 Other HVAC Systems and Equipment			0			NIC
D40	Fire Protection			\$0	\$0	0.00%	NIC
	D4010 Sprinklers			0			NIC
	D4020 Standpipes			0			NIC
	D4030 Fire Protection Specialties			0			NIC

August 08, 2013

CITY OF CAMBRIDGE
Cambridge, MA
AV Upgrades

Architect : LDa Architects, LLP

Senior Center

SUMMARY

	Total Program Area	GFA	Raw Rate/SF (excl all markups)	Elements Subtotal	Est. Cost	% of ECC	Notes
	D4090 Other Fire Protection Systems			0			NIC
D50	Electrical			\$41,010	\$41,010	24.52%	
	D5010 Electrical Service and Distribution			0			NIC
	D5020 Lighting and Branch Wiring			41,010			
	D5030 Communications and Security			In AV			
	D5090 Other Electrical Systems			0			NIC
E	Equipment and Furnishings				\$0	0.00%	NIC
E10	Equipment				\$0		NIC
	E1010 Commerical Equipment			0			NIC
	E1020 Institutional Equipment			0			NIC
	E1030 Vehicular Equipment			0			NIC
	E1090 Other Equipment			0			NIC
E20	Furnishings				\$0		NIC
	E2010 Fixed Furnishings			0			NIC
	E2020 Movable Furnishings			0			NIC
F	Special Construction & Demolition				\$8,000	4.78%	NIC
F10	Special Construction				\$0		NIC
	F1010 Special Structures			0			NIC
	F1020 Integrated Construction			0			NIC
	F1030 Vehicular Equipment			0			NIC
	F1040 Special Facilities			0			NIC
	F1050 Special Controls and Instrumentation			0			NIC
F20	Selective Building Demolition				\$8,000		
	F2010 Building Elements Demolition			8,000			
	F2020 Hazardous Components Abatement			0			NIC
	Building Total				\$138,510		
Z	General Requirements, General Conditions, Insurance, Bond, & Permit				20,777	15.00%	
	Contractor's Overhead & Profit				7,964	5.00%	
	Subtotal ECC Before Contingencies				\$167,251		
	Contingencies						
	Design Contingency				25,088	15.00%	
	Construction Contingency						Excluded
	Off hour work				19,234	10.00%	
	Escalation Contingency				6,732	3.50%	
	Total ECC with contingencies				\$218,304		
	<i>Total Rate/SF with contingencies</i>						

August 08, 2013

CITY OF CAMBRIDGE
 Cambridge, MA
 AV Upgrades

Architect : LDa Architects, LLP

Senior Center

Code	Description	Quantity	Unit	Rate	Assembly Cost
A	SUBSTRUCTURE				
A10	FOUNDATIONS				
A1010	Standard Foundations				\$ -
	No items in this section				
A1020	Special Foundations				\$ -
	No items in this section				
A1030	Slab on Grade				\$ -
	No items in this section				
A20	BASEMENT CONSTRUCTION				
A2010	Basement Excavation				\$ -
	No items in this section				
A2020	Basement Walls				\$ -
	No items in this section				
B	SHELL				
B10	SUPERSTRUCTURE				
B1010	Floor Construction				\$ -
	No items in this section				
B1020	Roof Construction				\$ -
B20	ENCLOSURE				
B2010	Exterior Walls				\$ -
	No items in this section				
B2020	Exterior Windows				\$ -
	No items in this section				
B2030	Exterior Doors				\$ -
	No items in this section				
B30	ROOFING				
B3010	Roof Coverings				\$ -
	No items in this section				
B3020	Roof Openings				\$ -
	No items in this section				

August 08, 2013

CITY OF CAMBRIDGE
 Cambridge, MA
 AV Upgrades

Architect : LDa Architects, LLP

Senior Center

C	INTERIORS				
C10	INTERIOR CONSTRUCTION				
C1010	Partitions				\$ -
	No items in this section				
C1020	Interior Doors				\$ 34,500
	Moveable partition including head & jamb modifications	1	LS	\$ 30,000.00	30,000
	Gaskets to doors	8	EA	\$ 450.00	3,600
	Auto door bottoms & thresholds	1	LS	\$ 900.00	900
C1030	Fittings				\$ -
	No items in this section				
C20	STAIRS				
C2010	Stair Construction				\$ -
	No items in this section				
C2020	Stair Finishes				\$ -
	No items in this section				
C30	INTERIOR FINISHES				
C3010	Wall Finishes				\$ 10,000
	Retractable velour curtains	1	LS	\$ 10,000.00	10,000
C3020	Floor Finishes				\$ 7,000
	Carpet - room above	1	LS	\$ 7,000.00	7,000
C3030	Ceiling Finishes				\$ -
	No items in this section				
D	SERVICES				
D10	CONVEYING				
D1010	Elevators and Lifts				\$ -
	No items in this section				
D1020	Escalators and Moving Walks				\$ -
	No items in this section				
D1090	Other Conveying Systems				\$ -
	No items in this section				

August 08, 2013

CITY OF CAMBRIDGE
Cambridge, MA
AV Upgrades

Architect : LDa Architects, LLP

Senior Center

D20	PLUMBING				
D2010	Plumbing Fixtures				\$ -
	No items in this section				
D2020	Domestic Water Distribution				\$ -
	No items in this section				
D2030	Sanitary Waste				\$ -
	No items in this section				
D2040	Rain Water Drainage				\$ -
	No items in this section				
D2090	Other Plumbing Systems				\$ -
	No items in this section				
D30	HVAC				
D3010	Energy Supply				\$ -
	No items in this section				
D3020	Heat Generating Systems				\$ -
	No items in this section				
D3030	Cooling Generating Systems				\$ 15,000
	Allowance for modification to existing	1	LS	\$ 15,000.00	15,000
D3040	Distribution Systems				\$ 20,000
	Allowance	1	LS	\$ 20,000.00	20,000
D3050	Terminal and Package Units				\$ -
	No items in this section				
D3060	Controls and Instrumentation				\$ 1,500
	Allowance for modification to existing	1	LS	\$ 1,500.00	1,500
D3070	Systems Testing and Balancing				\$ 1,500
	Allowance	1	LS	\$ 1,500.00	1,500
D3090	Other HVAC Systems and Equipment				\$ -
	No items in this section				

August 08, 2013

CITY OF CAMBRIDGE
Cambridge, MA
AV Upgrades

Architect : LDa Architects, LLP

Senior Center

D40	FIRE PROTECTION					
D4010	Sprinklers					\$ -
	No items in this section					
D4020	Standpipes					\$ -
	No items in this section					
D4030	Fire Protection Specialties					\$ -
	No items in this section					
D4090	Other Fire Protection Systems					\$ -
	No items in this section					
D50	ELECTRICAL					
D5010	Electrical Service and Distribution					\$ -
	No items in this section					
D5020	Lighting and Branch Wiring					\$ 41,010
	Light Fixtures					
	type S1	9	EA	\$ 1,000.00		9,000
	type R3	33	EA	\$ 325.00		10,725
	type R5	18	EA	\$ 450.00		8,100
	type XC (relamping only)	9	EA	\$ 125.00		1,125
	3/4" EMT (w 3#12)	1,140	LF	\$ 10.00		11,400
	Switches w/ MC Cables	6	EA	\$ 110.00		660
D5030	Communications and Security					\$ 74,620
	Electric Projection Screen	1	EA	\$ 2,100.00		2,100
	Video Projector	2	EA	\$ 6,000.00		12,000
	Video Display Ceiling Mount	2	EA	\$ 200.00		400
	VCR/Blu-ray DVD Combo Player	1	EA	\$ 200.00		200
	Ceiling Loudspeakers	9	EA	\$ 200.00		1,800
	Wireless Microphone System	2	EA	\$ 1,300.00		2,600
	Digital Audio Signal Processor	1	EA	\$ 7,000.00		7,000
	Assistive Listening System	1	EA	\$ 1,200.00		1,200
	Audio Power Amplifier	1	EA	\$ 1,100.00		1,100
	Video/Audio Routing Equipment	1	EA	\$ 12,000.00		12,000
	AV Control Panel	2	EA	\$ 500.00		1,000
	Digital Video Encoder	1	EA	\$ 3,500.00		3,500
	Video Monitor	1	EA	\$ 400.00		400
	Fiber Optic Transmission Equipment	1	EA	\$ 3,000.00		3,000
	Equipment Rack	1	EA	\$ 1,000.00		1,000
	Miscellaneous Hardware & Cable	1	EA	\$ 2,000.00		2,000

August 08, 2013

CITY OF CAMBRIDGE
 Cambridge, MA
 AV Upgrades

Architect : LDa Architects, LLP

Senior Center

	Installation of above	1	LS	\$ 17,955.00	17,955
	Control System Programming	1	EA	\$ 2,565.00	2,565
	Power Requirement allowance	1	LS	\$ 1,050.00	1,050
	Empty Conduit & backboxes	1	LS	\$ 1,750.00	1,750
D5090	Other Electrical Systems				\$ -
	No items in this section				
E	EQUIPMENT & FURNISHINGS				
E10	EQUIPMENT				
E1010	Commercial Equipment				\$ -
	No items in this section				
E1020	Institutional Equipment				\$ -
	No items in this section				
E1030	Vehicular Equipment				\$ -
	No items in this section				
E1090	Other Equipment				\$ -
	No items in this section				
E20	FURNISHINGS				
E2010	Fixed Furnishings				\$ -
	No items in this section				
E2020	Movable Furnishings				\$ -
	No items in this section				
F	SPECIAL CONSTRUCTION & DEMOLITION				
F10	SPECIAL CONSTRUCTION				
F1010	Special Structures				\$ -
	No items in this section				
F1020	Integrated Construction				\$ -
	No items in this section				
F1030	Vehicular Equipment				\$ -
	No items in this section				

August 08, 2013

CITY OF CAMBRIDGE
 Cambridge, MA
 AV Upgrades

Architect : LDa Architects, LLP

Senior Center

F1040	Special Facilities				\$	-
	No items in this section					
F1050	Special Controls and Instrumentation				\$	-
	No items in this section					
F20	SELECTIVE BUILDING DEMOLITION					
F2010	Building Elements Demolition				\$	8,000
	Allowance	1	LS	\$ 8,000.00		8,000
F2020	Hazard Components Abatement				\$	-
	No items in this section					

City Hall Annex

SUMMARY

Total Program Area			GFA	Raw Rate/SF (excl all markups)	Elements Subtotal	Est. Cost	% of ECC	Notes
A	Substructure					\$0	0.00%	NIC
A10	Foundations				\$0			NIC
	A1010	Standard Foundations			0			NIC
	A1020	Special Foundations			0			NIC
	A1030	Slab on Grade			0			NIC
A20	Basement Construction				\$0			NIC
	A2010	Basement Excavation			0			NIC
	A2020	Basement Walls			0			NIC
B	Shell					\$0	0.00%	NIC
B10	Superstructure				\$0			NIC
	B1010	Floor Construction			0			NIC
	B1020	Roof Construction			0			NIC
B20	Exterior Enclosure				\$0			NIC
	B2010	Exterior Walls			0			NIC
	B2020	Exterior Windows			0			NIC
	B2030	Exterior Doors			0			NIC
B30	Roofing				\$0			NIC
	B3010	Roof Coverings			0			NIC
	B3020	Roof Openings			0			NIC
C	Interiors					\$9,000	43.08%	
C10	Interior Construction				\$3,000			
	C1010	Partitions			3,000			
	C1020	Interior Doors			0			NIC
	C1030	Fittings			0			NIC
C20	Stairs				\$0			NIC
	C2010	Stair Construction			0			NIC
	C2020	Stair Finishes			0			NIC
C30	Interior Finishes				\$6,000			
	C3010	Wall Finishes			3,000			
	C3020	Floor Finishes			0			NIC
	C3030	Ceiling Finishes			3,000			
D	Services							
D10	Conveying				\$0	\$0	0.00%	NIC
	D1010	Elevators and Lifts			0			NIC
	D1020	Escalators and Moving Walks			0			NIC
	D1090	Other Conveying Systems			0			NIC
D20	Plumbing				\$0	\$0	0.00%	NIC
	D2010	Plumbing Fixtures			0			NIC
	D2020	Domestic Water Distribution			0			NIC
	D2030	Sanitary Waste			0			NIC
	D2040	Rain Water Drainage			0			NIC
	D2090	Other Plumbing Services			0			NIC
D30	HVAC				\$7,500	\$7,500	35.90%	
	D3010	Energy Supply			0			NIC
	D3020	Heat Generating Systems			0			NIC
	D3030	Cooling Generating Sytems			0			NIC
	D3040	Distribution Systems			7,500			
	D3050	Terminal and Package Units			0			NIC
	D3060	Controls and Instrumentation			0			NIC
	D3070	Systems Testing and Balancing			0			NIC
	D3090	Other HVAC Systems and Equipment			0			NIC
D40	Fire Protection				\$0	\$0	0.00%	NIC
	D4010	Sprinklers			0			NIC
	D4020	Standpipes			0			NIC
	D4030	Fire Protection Specialties			0			NIC
	D4090	Other Fire Protection Systems			0			NIC
D50	Electrical				\$0	\$0	0.00%	NIC
	D5010	Electrical Service and Distribution			0			NIC
	D5020	Lighting and Branch Wiring			0			NIC

August 08, 2013

CITY OF CAMBRIDGE
Cambridge, MA
AV Upgrades

Architect : LDa Architects, LLP

City Hall Annex

SUMMARY

Total Program Area		GFA	Raw Rate/SF (excl all markups)	Elements Subtotal	Est. Cost	% of ECC	Notes
	D5030 Communications and Security			In AV			
	D5090 Other Electrical Systems			0			NIC
E	Equipment and Furnishings				\$0	0.00%	NIC
E10	Equipment			\$0			NIC
	E1010 Commerical Equipment			0			NIC
	E1020 Institutional Equipment			0			NIC
	E1030 Vehicular Equipment			0			NIC
	E1090 Other Equipment			0			NIC
E20	Furnishings			\$0			NIC
	E2010 Fixed Furnishings			0			NIC
	E2020 Movable Furnishings			0			NIC
F	Special Construction & Demolition				\$800	3.83%	NIC
F10	Special Construction			\$0			NIC
	F1010 Special Structures			0			NIC
	F1020 Integrated Construction			0			NIC
	F1030 Vehicular Equipment			0			NIC
	F1040 Special Facilities			0			NIC
	F1050 Special Controls and Instrumentation			0			NIC
F20	Selective Building Demolition			\$800			
	F2010 Building Elements Demolition			800			
	F2020 Hazardous Components Abatement			0			NIC
	Building Total				\$17,300		
Z	General Requirements, General Conditions, Insurance, Bond, & Permit				2,595	15.00%	
	Contractor's Overhead & Profit				995	5.00%	
	Subtotal ECC Before Contingencies				\$20,890		
	Contingencies						
	Design Contingency				3,133	15.00%	
	Construction Contingency						Excluded
	Off hour work				2,402	10.00%	
	Escalation Contingency				841	3.50%	
	Total ECC with contingencies				\$27,266		
	Total Rate/SF with contingencies						

August 08, 2013

CITY OF CAMBRIDGE
Cambridge, MA
AV Upgrades

Architect : LDa Architects, LLP

City Hall Annex

Code	Description	Quantity	Unit	Rate	Assembly Cost
A	SUBSTRUCTURE				
A10	FOUNDATIONS				
A1010	Standard Foundations				\$ -
	No items in this section				
A1020	Special Foundations				\$ -
	No items in this section				
A1030	Slab on Grade				\$ -
	No items in this section				
A20	BASEMENT CONSTRUCTION				
A2010	Basement Excavation				\$ -
	No items in this section				
A2020	Basement Walls				\$ -
	No items in this section				
B	SHELL				
B10	SUPERSTRUCTURE				
B1010	Floor Construction				\$ -
	No items in this section				
B1020	Roof Construction				\$ -
	No items in this section				
B20	ENCLOSURE				
B2010	Exterior Walls				\$ -
	No items in this section				
B2020	Exterior Windows				\$ -
	No items in this section				
B2030	Exterior Doors				\$ -
	No items in this section				
B30	ROOFING				
B3010	Roof Coverings				\$ -
	No items in this section				
B3020	Roof Openings				\$ -
	No items in this section				
C	INTERIORS				
C10	INTERIOR CONSTRUCTION				
C1010	Partitions				\$ 3,000
	Patch existing wall	1	LS	\$ 3,000.00	3,000

August 08, 2013

CITY OF CAMBRIDGE
Cambridge, MA
AV Upgrades

Architect : LDa Architects, LLP

City Hall Annex

C1020	Interior Doors					\$ -
	No items in this section					
C1030	Fittings					\$ -
	No items in this section					
C20	STAIRS					
C2010	Stair Construction					\$ -
	No items in this section					
C2020	Stair Finishes					\$ -
	No items in this section					
C30	INTERIOR FINISHES					
C3010	Wall Finishes					\$ 3,000
	Repair to existng wall	1	LS	\$ 3,000.00		3,000
C3020	Floor Finishes					\$ -
	No items in this section					
C3030	Ceiling Finishes					\$ 3,000
	Patch or repair to existing	1	LS	\$ 3,000.00		3,000
D	SERVICES					
D10	CONVEYING					
D1010	Elevators and Lifts					\$ -
	No items in this section					
D1020	Escalators and Moving Walks					\$ -
	No items in this section					
D1090	Other Conveying Systems					\$ -
	No items in this section					
D20	PLUMBING					
D2010	Plumbing Fixtures					\$ -
	No items in this section					
D2020	Domestic Water Distribution					\$ -
	No items in this section					
D2030	Sanitary Waste					\$ -
	No items in this section					
D2040	Rain Water Drainage					\$ -
	No items in this section					
D2090	Other Plumbing Systems					\$ -
	No items in this section					

August 08, 2013

CITY OF CAMBRIDGE
Cambridge, MA
AV Upgrades

Architect : LDa Architects, LLP

City Hall Annex

D30	HVAC					
D3010	Energy Supply					\$ -
	No items in this section					
D3020	Heat Generating Systems					\$ -
	No items in this section					
D3030	Cooling Generating Systems					\$ -
	No items in this section					
D3040	Distribution Systems					\$ 7,500
	Allowance for modification to existing	1	LS	\$ 7,500.00		7,500
D3050	Terminal and Package Units					\$ -
	No items in this section					
D3060	Controls and Instrumentation					\$ -
	No items in this section					
D3070	Systems Testing and Balancing					\$ -
	No items in this section					
D3090	Other HVAC Systems and Equipment					\$ -
	No items in this section					
D40	FIRE PROTECTION					
D4010	Sprinklers					\$ -
	No items in this section					
D4020	Standpipes					\$ -
	No items in this section					
D4030	Fire Protection Specialties					\$ -
	No items in this section					
D4090	Other Fire Protection Systems					\$ -
	No items in this section					
D50	ELECTRICAL					
D5010	Electrical Service and Distribution					\$ -
	No items in this section					
D5020	Lighting and Branch Wiring					\$ -
	No items in this section					
D5030	Communications and Security					\$ 35,950
	High-Brightness Video Projector	1	EA	\$ 9,000.00		9,000
	Blu-ray DVD Player	1	EA	\$ 200.00		200
	Wireless Microphone (Existing)					ETR
	Power Amplifier	1	EA	\$ 800.00		800
	Assistive Listening System	1	EA	\$ 1,400.00		1,400
	Video/Audio Routing Equipment	1	EA	\$ 10,000.00		10,000

August 08, 2013

CITY OF CAMBRIDGE
Cambridge, MA
AV Upgrades

Architect : LDa Architects, LLP

City Hall Annex

	AV Control Touchscreen	1	EA	\$ 1,600.00	1,600
	Miscellaneous Hardware & Cable	1	EA	\$ 1,500.00	1,500
	Installation of above	1	LS	\$ 8,575.00	8,575
	Control System Programming	1	EA	\$ 1,225.00	1,225
	Power Requirement allowance	1	LS	\$ 550.00	550
	Empty Conduit & backboxes	1	LS	\$ 1,100.00	1,100
	D5090 Other Electrical Systems				\$ -
	No items in this section				
E	EQUIPMENT & FURNISHINGS				
E10	EQUIPMENT				
	E1010 Commercial Equipment				\$ -
	No items in this section				
	E1020 Institutional Equipment				\$ -
	No items in this section				
	E1030 Vehicular Equipment				\$ -
	No items in this section				
	E1090 Other Equipment				\$ -
	No items in this section				
E20	FURNISHINGS				
	E2010 Fixed Furnishings				\$ -
	No items in this section				
	E2020 Movable Furnishings				\$ -
	No items in this section				
F	SPECIAL CONSTRUCTION & DEMOLITION				
F10	SPECIAL CONSTRUCTION				
	F1010 Special Structures				\$ -
	No items in this section				
	F1020 Integrated Construction				\$ -
	No items in this section				
	F1030 Vehicular Equipment				\$ -
	No items in this section				
	F1040 Special Facilities				\$ -
	No items in this section				
	F1050 Special Controls and Instrumentation				\$ -
	No items in this section				

August 08, 2013

CITY OF CAMBRIDGE
Cambridge, MA
AV Upgrades

Architect : LDa Architects, LLP

City Hall Annex

F20	SELECTIVE BUILDING DEMOLITION				
F2010	Building Elements Demolition				\$ 800
	Allowance	1	LS	\$ 800.00	800
F2020	Hazard Components Abatement				\$ -
	No items in this section				

August 08, 2013

CITY OF CAMBRIDGE
 Cambridge, MA
 AV Upgrades

Architect : LDa Architects, LLP

Water Department

SUMMARY

	Total Program Area	GFA	Raw Rate/SF (excl all markups)	Elements Subtotal	Est. Cost	% of ECC	Notes
A	Substructure				\$0	0.00%	NIC
A10	Foundations			\$0			NIC
	A1010 Standard Foundations			0			NIC
	A1020 Special Foundations			0			NIC
	A1030 Slab on Grade			0			NIC
A20	Basement Construction			\$0			NIC
	A2010 Basement Excavation			0			NIC
	A2020 Basement Walls			0			NIC
B	Shell				\$0	50000.00%	NIC
B10	Superstructure			\$0			NIC
	B1010 Floor Construction			0			NIC
	B1020 Roof Construction			0			NIC
B20	Exterior Enclosure			\$0			NIC
	B2010 Exterior Walls			0			NIC
	B2020 Exterior Windows			0			NIC
	B2030 Exterior Doors			0			NIC
B30	Roofing			\$0			NIC
	B3010 Roof Coverings			0			NIC
	B3020 Roof Openings			0			NIC
C	Interiors				\$80,600	81.30%	
C10	Interior Construction			\$600			
	C1010 Partitions			0			NIC
	C1020 Interior Doors			600			
	C1030 Fittings			0			NIC
C20	Stairs			\$0			NIC
	C2010 Stair Construction			0			NIC
	C2020 Stair Finishes			0			NIC
C30	Interior Finishes			\$80,000			
	C3010 Wall Finishes			30,000			
	C3020 Floor Finishes			0			NIC
	C3030 Ceiling Finishes			50,000			
D	Services						
D10	Conveying			\$0	\$0	0.00%	NIC
	D1010 Elevators and Lifts			0			NIC
	D1020 Escalators and Moving Walks			0			NIC
	D1090 Other Conveying Systems			0			NIC
D20	Plumbing			\$0	\$0	0.00%	NIC
	D2010 Plumbing Fixtures			0			NIC
	D2020 Domestic Water Distribution			0			NIC
	D2030 Sanitary Waste			0			NIC
	D2040 Rain Water Drainage			0			NIC
	D2090 Other Plumbing Services			0			NIC
D30	HVAC			\$0	\$0	0.00%	NIC
	D3010 Energy Supply			0			NIC
	D3020 Heat Generating Systems			0			NIC
	D3030 Cooling Generating Systems			0			NIC
	D3040 Distribution Systems			0			NIC
	D3050 Terminal and Package Units			0			NIC
	D3060 Controls and Instrumentation			0			NIC
	D3070 Systems Testing and Balancing			0			NIC
	D3090 Other HVAC Systems and Equipment			0			NIC
D40	Fire Protection			\$0	\$0	0.00%	NIC
	D4010 Sprinklers			0			NIC
	D4020 Standpipes			0			NIC
	D4030 Fire Protection Specialties			0			NIC
	D4090 Other Fire Protection Systems			0			NIC

August 08, 2013

CITY OF CAMBRIDGE
 Cambridge, MA
 AV Upgrades

Architect : LDa Architects, LLP

Water Department

SUMMARY

	Total Program Area	GFA	Raw Rate/SF (excl all markups)	Elements Subtotal	Est. Cost	% of ECC	Notes
D50	Electrical			\$0	\$0	0.00%	NIC
	D5010 Electrical Service and Distribution			0			NIC
	D5020 Lighting and Branch Wiring			0			NIC
	D5030 Communications and Security			In AV			
	D5090 Other Electrical Systems			0			NIC
							NIC
E	Equipment and Furnishings				\$0	0.00%	NIC
E10	Equipment			\$0			NIC
	E1010 Commerical Equipment			0			NIC
	E1020 Institutional Equipment			0			NIC
	E1030 Vehicular Equipment			0			NIC
	E1090 Other Equipment			0			NIC
E20	Furnishings			\$0			NIC
	E2010 Fixed Furnishings			0			NIC
	E2020 Movable Furnishings			0			NIC
							NIC
F	Special Construction & Demolition				\$1,500	1.51%	NIC
F10	Special Construction			\$0			NIC
	F1010 Special Structures			0			NIC
	F1020 Integrated Construction			0			NIC
	F1030 Vehicular Equipment			0			NIC
	F1040 Special Facilities			0			NIC
	F1050 Special Controls and Instrumentation			0			NIC
F20	Selective Building Demolition			\$1,500			
	F2010 Building Elements Demolition			1,500			
	F2020 Hazardous Components Abatement			0			NIC
	Building Total				\$82,100		
Z	General Requirements, General Conditions, Insurance, Bond, & Permit				12,315	15.00%	
	Contractor's Overhead & Profit				4,721	5.00%	
	Subtotal ECC Before Contingencies				\$99,136		
	Contingencies						
	Design Contingency				14,870	15.00%	
	Construction Contingency						Excluded
	Off hour work				11,401	10.00%	
	Escalation Contingency				3,990	3.50%	
	Total ECC with contingencies				\$129,397		
	<i>Total Rate/SF with contingencies</i>						

August 08, 2013

CITY OF CAMBRIDGE
 Cambridge, MA
 AV Upgrades

Architect : LDa Architects, LLP

Water Department

Code	Description	Quantity	Unit	Rate	Assembly Cost
A	SUBSTRUCTURE				
A10	FOUNDATIONS				
A1010	Standard Foundations				\$ -
	No items in this section				
A1020	Special Foundations				\$ -
	No items in this section				
A1030	Slab on Grade				\$ -
	No items in this section				
A20	BASEMENT CONSTRUCTION				
A2010	Basement Excavation				\$ -
	No items in this section				
A2020	Basement Walls				\$ -
	No items in this section				
B	SHELL				
B10	SUPERSTRUCTURE				
B1010	Floor Construction				\$ -
	No items in this section				
B1020	Roof Construction				\$ -
B20	ENCLOSURE				
B2010	Exterior Walls				\$ -
	No items in this section				
B2020	Exterior Windows				\$ -
	No items in this section				
B2030	Exterior Doors				\$ -
	No items in this section				
B30	ROOFING				
B3010	Roof Coverings				\$ -
	No items in this section				
B3020	Roof Openings				\$ -
	No items in this section				

August 08, 2013

CITY OF CAMBRIDGE
 Cambridge, MA
 AV Upgrades

Architect : LDa Architects, LLP

Water Department

C	INTERIORS				
C10	INTERIOR CONSTRUCTION				
C1010	Partitions				\$ -
	No items in this section				
C1020	Interior Doors				\$ 600
	Gaskets to doors	2	EA	\$ 300.00	600
C1030	Fittings				\$ -
	No items in this section				
C20	STAIRS				
C2010	Stair Construction				\$ -
	No items in this section				
C2020	Stair Finishes				\$ -
	No items in this section				
C30	INTERIOR FINISHES				
C3010	Wall Finishes				\$ 30,000
	Acoustic treatment to existing wall	1	LS	\$ 30,000.00	30,000
C3020	Floor Finishes				\$ -
	No items in this section				
C3030	Ceiling Finishes				\$ 50,000
	Acoustic treatment to existing ceiling	1	LS	\$ 50,000.00	50,000
D	SERVICES				
D10	CONVEYING				
D1010	Elevators and Lifts				\$ -
	No items in this section				
D1020	Escalators and Moving Walks				\$ -
	No items in this section				
D1090	Other Conveying Systems				\$ -
	No items in this section				

August 08, 2013

CITY OF CAMBRIDGE
 Cambridge, MA
 AV Upgrades

Architect : LDa Architects, LLP

Water Department

D20	PLUMBING				
D2010	Plumbing Fixtures				\$ -
	No items in this section				
D2020	Domestic Water Distribution				\$ -
	No items in this section				
D2030	Sanitary Waste				\$ -
	No items in this section				
D2040	Rain Water Drainage				\$ -
	No items in this section				
D2090	Other Plumbing Systems				\$ -
	No items in this section				
D30	HVAC				
D3010	Energy Supply				\$ -
	No items in this section				
D3020	Heat Generating Systems				\$ -
	No items in this section				
D3030	Cooling Generating Systems				\$ -
	No items in this section				
D3040	Distribution Systems				\$ -
	No items in this section				
D3050	Terminal and Package Units				\$ -
	No items in this section				
D3060	Controls and Instrumentation				\$ -
	No items in this section				
D3070	Systems Testing and Balancing				\$ -
	No items in this section				
D3090	Other HVAC Systems and Equipment				\$ -
	No items in this section				
D40	FIRE PROTECTION				
D4010	Sprinklers				\$ -
	No items in this section				

August 08, 2013

CITY OF CAMBRIDGE
 Cambridge, MA
 AV Upgrades

Architect : LDa Architects, LLP

Water Department

D4020	Standpipes					\$ -
	No items in this section					
D4030	Fire Protection Specialties					\$ -
	No items in this section					
D4090	Other Fire Protection Systems					\$ -
	No items in this section					
D50	ELECTRICAL					
D5010	Electrical Service and Distribution					\$ -
	No items in this section					
D5020	Lighting and Branch Wiring					\$ -
	No items in this section					
D5030	Communications and Security					\$ 19,741
	Steerable Column Loudspeaker	1	EA	\$ 10,000.00		10,000
	Wireless Microphone Systems	1	EA	\$ 1,500.00		1,500
	Lectern Gooseneck Microphone	1	EA	\$ 350.00		350
	AV Control Panel	1	EA	\$ 500.00		500
	Miscellaneous Hardware & Cable	1	EA	\$ 1,000.00		1,000
	Installation of above	1	EA	\$ 4,673.00		4,673
	Control System Programming	1	EA	\$ 668.00		668
	Power Requirement allowance	1	LS	\$ 350.00		350
	Empty Conduit & backboxes	1	LS	\$ 700.00		700
D5090	Other Electrical Systems					\$ -
	No items in this section					
E	EQUIPMENT & FURNISHINGS					
E10	EQUIPMENT					
E1010	Commercial Equipment					\$ -
	No items in this section					
E1020	Institutional Equipment					\$ -
	No items in this section					
E1030	Vehicular Equipment					\$ -
	No items in this section					

August 08, 2013

CITY OF CAMBRIDGE
 Cambridge, MA
 AV Upgrades

Architect : LDa Architects, LLP

Water Department

E1090	Other Equipment					\$ -
	No items in this section					
E20	FURNISHINGS					
E2010	Fixed Furnishings					\$ -
	No items in this section					
E2020	Movable Furnishings					\$ -
	No items in this section					
F	SPECIAL CONSTRUCTION & DEMOLITION					
F10	SPECIAL CONSTRUCTION					
F1010	Special Structures					\$ -
	No items in this section					
F1020	Integrated Construction					\$ -
	No items in this section					
F1030	Vehicular Equipment					\$ -
	No items in this section					
F1040	Special Facilities					\$ -
	No items in this section					
F1050	Special Controls and Instrumentation					\$ -
	No items in this section					
F20	SELECTIVE BUILDING DEMOLITION					
F2010	Building Elements Demolition					\$ 1,500
	Allowance	1	LS	\$ 1,500.00		1,500
F2020	Hazard Components Abatement					\$ -
	No items in this section					

Lombardi Building

SUMMARY

	Total Program Area	GFA	Raw Rate/SF (excl all markups)	Elements Subtotal	Est. Cost	% of ECC	Notes
A	Substructure				\$0	0.00%	NIC
A10	Foundations			\$0			NIC
	A1010 Standard Foundations			0			NIC
	A1020 Special Foundations			0			NIC
	A1030 Slab on Grade			0			NIC
A20	Basement Construction			\$0			NIC
	A2010 Basement Excavation			0			NIC
	A2020 Basement Walls			0			NIC
B	Shell				\$0	50000.00%	NIC
B10	Superstructure			\$0			NIC
	B1010 Floor Construction			0			NIC
	B1020 Roof Construction			0			NIC
B20	Exterior Enclosure			\$0			NIC
	B2010 Exterior Walls			0			NIC
	B2020 Exterior Windows			0			NIC
	B2030 Exterior Doors			0			NIC
B30	Roofing			\$0			NIC
	B3010 Roof Coverings			0			NIC
	B3020 Roof Openings			0			NIC
C	Interiors				\$5,000	12.73%	
C10	Interior Construction			\$0			NIC
	C1010 Partitions			0			NIC
	C1020 Interior Doors			0			NIC
	C1030 Fittings			0			NIC
C20	Stairs			\$0			NIC
	C2010 Stair Construction			0			NIC
	C2020 Stair Finishes			0			NIC
C30	Interior Finishes			\$5,000			
	C3010 Wall Finishes			0			NIC
	C3020 Floor Finishes			0			NIC
	C3030 Ceiling Finishes			5,000			
D	Services						
D10	Conveying			\$0	\$0	0.00%	NIC
	D1010 Elevators and Lifts			0			NIC
	D1020 Escalators and Moving Walks			0			NIC
	D1090 Other Conveying Systems			0			NIC
D20	Plumbing			\$0	\$0	0.00%	NIC
	D2010 Plumbing Fixtures			0			NIC
	D2020 Domestic Water Distribution			0			NIC
	D2030 Sanitary Waste			0			NIC
	D2040 Rain Water Drainage			0			NIC
	D2090 Other Plumbing Services			0			NIC
D30	HVAC			\$17,000	\$17,000	43.29%	
	D3010 Energy Supply			0			NIC
	D3020 Heat Generating Systems			0			NIC
	D3030 Cooling Generating Sytems			8,000			
	D3040 Distribution Systems			8,000			
	D3050 Terminal and Package Units			0			NIC
	D3060 Controls and Instrumentation			0			NIC
	D3070 Systems Testing and Balancing			1,000			
	D3090 Other HVAC Systems and Equipment			0			NIC
D40	Fire Protection			\$0	\$0	0.00%	NIC
	D4010 Sprinklers			0			NIC
	D4020 Standpipes			0			NIC
	D4030 Fire Protection Specialties			0			NIC
	D4090 Other Fire Protection Systems			0			NIC

August 08, 2013

CITY OF CAMBRIDGE
Cambridge, MA
AV Upgrades

Architect : LDa Architects, LLP

Lombardi Building

SUMMARY

Total Program Area		GFA	Raw Rate/SF (excl all markups)	Elements Subtotal	Est. Cost	% of ECC	Notes
D50	Electrical			\$7,520	\$7,520	19.15%	
	D5010 Electrical Service and Distribution			0			NIC
	D5020 Lighting and Branch Wiring			7,520			
	D5030 Communications and Security			In AV			
	D5090 Other Electrical Systems			0			NIC
E	Equipment and Furnishings				\$0	0.00%	NIC
E10	Equipment			\$0			NIC
	E1010 Commerical Equipment			0			NIC
	E1020 Institutional Equipment			0			NIC
	E1030 Vehicular Equipment			0			NIC
	E1090 Other Equipment			0			NIC
E20	Furnishings			\$0			NIC
	E2010 Fixed Furnishings			0			NIC
	E2020 Movable Furnishings			0			NIC
F	Special Construction & Demolition				\$3,000	7.64%	NIC
F10	Special Construction			\$0			NIC
	F1010 Special Structures			0			NIC
	F1020 Integrated Construction			0			NIC
	F1030 Vehicular Equipment			0			NIC
	F1040 Special Facilities			0			NIC
	F1050 Special Controls and Instrumentation			0			NIC
F20	Selective Building Demolition			\$3,000			
	F2010 Building Elements Demolition			3,000			
	F2020 Hazardous Components Abatement			0			NIC
	Building Total				\$32,520		
Z	General Requirements, General Conditions, Insurance, Bond, & Permit				4,878	15.00%	
	Contractor's Overhead & Profit				1,870	5.00%	
	Subtotal ECC Before Contingencies				\$39,268		
	Contingencies						
	Design Contingency				5,890	15.00%	
	Construction Contingency						Excluded
	Off hour work				4,516	10.00%	
	Escalation Contingency				1,581	3.50%	
	Total ECC with contingencies				\$51,254		
	<i>Total Rate/SF with contingencies</i>						

August 08, 2013

CITY OF CAMBRIDGE
 Cambridge, MA
 AV Upgrades

Architect : LDa Architects, LLP

Lombardi Building

Code	Description	Quantity	Unit	Rate	Assembly Cost
A	SUBSTRUCTURE				
A10	FOUNDATIONS				
A1010	Standard Foundations				\$ -
	No items in this section				
A1020	Special Foundations				\$ -
	No items in this section				
A1030	Slab on Grade				\$ -
	No items in this section				
A20	BASEMENT CONSTRUCTION				
A2010	Basement Excavation				\$ -
	No items in this section				
A2020	Basement Walls				\$ -
	No items in this section				
B	SHELL				
B10	SUPERSTRUCTURE				
B1010	Floor Construction				\$ -
	No items in this section				
B1020	Roof Construction				\$ -
B20	ENCLOSURE				
B2010	Exterior Walls				\$ -
	No items in this section				
B2020	Exterior Windows				\$ -
	No items in this section				
B2030	Exterior Doors				\$ -
	No items in this section				
B30	ROOFING				
B3010	Roof Coverings				\$ -
	No items in this section				
B3020	Roof Openings				\$ -
	No items in this section				

August 08, 2013

CITY OF CAMBRIDGE
 Cambridge, MA
 AV Upgrades

Architect : LDa Architects, LLP

Lombardi Building

C	INTERIORS				
C10	INTERIOR CONSTRUCTION				
C1010	Partitions				\$ -
	No items in this section				
C1020	Interior Doors				\$ -
	No items in this section				
C1030	Fittings				\$ -
	No items in this section				
C20	STAIRS				
C2010	Stair Construction				\$ -
	No items in this section				
C2020	Stair Finishes				\$ -
	No items in this section				
C30	INTERIOR FINISHES				
C3010	Wall Finishes				\$ -
	No items in this section				
C3020	Floor Finishes				\$ -
	No items in this section				
C3030	Ceiling Finishes				\$ 5,000
	Patch or repair to existing	1	LS	\$ 5,000.00	5,000
D	SERVICES				
D10	CONVEYING				
D1010	Elevators and Lifts				\$ -
	No items in this section				
D1020	Escalators and Moving Walks				\$ -
	No items in this section				
D1090	Other Conveying Systems				\$ -
	No items in this section				

August 08, 2013

CITY OF CAMBRIDGE
 Cambridge, MA
 AV Upgrades

Architect : LDa Architects, LLP

Lombardi Building

D20	PLUMBING				
D2010	Plumbing Fixtures				\$ -
	No items in this section				
D2020	Domestic Water Distribution				\$ -
	No items in this section				
D2030	Sanitary Waste				\$ -
	No items in this section				
D2040	Rain Water Drainage				\$ -
	No items in this section				
D2090	Other Plumbing Systems				\$ -
	No items in this section				
D30	HVAC				
D3010	Energy Supply				\$ -
	No items in this section				
D3020	Heat Generating Systems				\$ -
	No items in this section				
D3030	Cooling Generating Systems				\$ 8,000
	Allowance for modification to existing	1	LS	\$ 8,000.00	8,000
D3040	Distribution Systems				\$ 8,000
	Allowance	1	LS	\$ 8,000.00	8,000
D3050	Terminal and Package Units				\$ -
	No items in this section				
D3060	Controls and Instrumentation				\$ -
	No items in this section				
D3070	Systems Testing and Balancing				\$ 1,000
	Allowance	1	LS	\$ 1,000.00	1,000
D3090	Other HVAC Systems and Equipment				\$ -
	No items in this section				
D40	FIRE PROTECTION				
D4010	Sprinklers				\$ -
	No items in this section				

August 08, 2013

CITY OF CAMBRIDGE
 Cambridge, MA
 AV Upgrades

Architect : LDa Architects, LLP

Lombardi Building

D4020	Standpipes					\$ -
	No items in this section					
D4030	Fire Protection Specialties					\$ -
	No items in this section					
D4090	Other Fire Protection Systems					\$ -
	No items in this section					
D50	ELECTRICAL					
D5010	Electrical Service and Distribution					\$ -
	No items in this section					
D5020	Lighting and Branch Wiring					\$ 7,520
	Light Fixtures					
	Type R6	6	EA	\$ 300.00		1,800
	3/4" EMT (w 3#12)	90	LF	\$ 10.00		900
	Switches w/ MC Cables	2	EA	\$ 110.00		220
	Dimmer control	4	EA	\$ 400.00		1,600
	Power to equipment	1	LS	\$ 3,000.00		3,000
D5030	Communications and Security					\$ 20,143
	Electric Projection Screen	1	EA	\$ 1,800.00		1,800
	Video Projector	1	EA	\$ 6,000.00		6,000
	Video Display Ceiling Mount	1	EA	\$ 200.00		200
	Video/Audio Transmission Equipment	1	EA	\$ 3,900.00		3,900
	AV Control Panel	1	EA	\$ 500.00		500
	Miscellaneous Hardware & Cable	1	EA	\$ 1,500.00		1,500
	Installation of above	1	EA	\$ 4,865.00		4,865
	Control System Programming	1	EA	\$ 278.00		278
	Power Requirement allowance	1	LS	\$ 375.00		375
	Empty Conduit & backboxes	1	LS	\$ 725.00		725
D5090	Other Electrical Systems					\$ -
	No items in this section					
E	EQUIPMENT & FURNISHINGS					
E10	EQUIPMENT					
E1010	Commercial Equipment					\$ -
	No items in this section					

August 08, 2013

CITY OF CAMBRIDGE
 Cambridge, MA
 AV Upgrades

Architect : LDa Architects, LLP

Lombardi Building

E1020	Institutional Equipment					\$ -
	No items in this section					
E1030	Vehicular Equipment					\$ -
	No items in this section					
E1090	Other Equipment					\$ -
	No items in this section					
E20	FURNISHINGS					
E2010	Fixed Furnishings					\$ -
	No items in this section					
E2020	Movable Furnishings					\$ -
	No items in this section					
F	SPECIAL CONSTRUCTION & DEMOLITION					
F10	SPECIAL CONSTRUCTION					
F1010	Special Structures					\$ -
	No items in this section					
F1020	Integrated Construction					\$ -
	No items in this section					
F1030	Vehicular Equipment					\$ -
	No items in this section					
F1040	Special Facilities					\$ -
	No items in this section					
F1050	Special Controls and Instrumentation					\$ -
	No items in this section					
F20	SELECTIVE BUILDING DEMOLITION					
F2010	Building Elements Demolition					\$ 3,000
	Allowance	1	LS	\$ 3,000.00		3,000
F2020	Hazard Components Abatement					\$ -
	No items in this section					

CITY OF CAMBRIDGE
Cambridge, MA
AV Upgrades

Architect : LDa Architects, LLP

Portable Video
SUMMARY

	Total Program Area	GFA	Raw Rate/SF (excl all markups)	Elements Subtotal	Est. Cost	% of ECC	Notes
A	Substructure				\$0	0.00%	NIC
A10	Foundations			\$0			NIC
	A1010 Standard Foundations			0			NIC
	A1020 Special Foundations			0			NIC
	A1030 Slab on Grade			0			NIC
A20	Basement Construction			\$0			NIC
	A2010 Basement Excavation			0			NIC
	A2020 Basement Walls			0			NIC
B	Shell				\$0	50000.00%	NIC
B10	Superstructure			\$0			NIC
	B1010 Floor Construction			0			NIC
	B1020 Roof Construction			0			NIC
B20	Exterior Enclosure			\$0			NIC
	B2010 Exterior Walls			0			NIC
	B2020 Exterior Windows			0			NIC
	B2030 Exterior Doors			0			NIC
B30	Roofing			\$0			NIC
	B3010 Roof Coverings			0			NIC
	B3020 Roof Openings			0			NIC
C	Interiors				\$0	0.00%	NIC
C10	Interior Construction			\$0			NIC
	C1010 Partitions			0			NIC
	C1020 Interior Doors			0			NIC
	C1030 Fittings			0			NIC
C20	Stairs			\$0			NIC
	C2010 Stair Construction			0			NIC
	C2020 Stair Finishes			0			NIC
C30	Interior Finishes			\$0			NIC
	C3010 Wall Finishes			0			NIC
	C3020 Floor Finishes			0			NIC
	C3030 Ceiling Finishes			0			NIC
D	Services						
D10	Conveying			\$0	\$0	0.00%	NIC
	D1010 Elevators and Lifts			0			NIC
	D1020 Escalators and Moving Walks			0			NIC
	D1090 Other Conveying Systems			0			NIC
D20	Plumbing			\$0	\$0	0.00%	NIC
	D2010 Plumbing Fixtures			0			NIC
	D2020 Domestic Water Distribution			0			NIC
	D2030 Sanitary Waste			0			NIC
	D2040 Rain Water Drainage			0			NIC
	D2090 Other Plumbing Services			0			NIC
D30	HVAC			\$0	\$0	0.00%	NIC
	D3010 Energy Supply			0			NIC
	D3020 Heat Generating Systems			0			NIC
	D3030 Cooling Generating Sytems			0			NIC
	D3040 Distribution Systems			0			NIC
	D3050 Terminal and Package Units			0			NIC
	D3060 Controls and Instrumentation			0			NIC
	D3070 Systems Testing and Balancing			0			NIC
	D3090 Other HVAC Systems and Equipment			0			NIC
D40	Fire Protection			\$0	\$0	0.00%	NIC
	D4010 Sprinklers			0			NIC
	D4020 Standpipes			0			NIC
	D4030 Fire Protection Specialties			0			NIC
	D4090 Other Fire Protection Systems			0			NIC

Portable Video
SUMMARY

Total Program Area		GFA	Raw Rate/SF (excl all markups)	Elements Subtotal	Est. Cost	% of ECC	Notes
D50	Electrical			\$43,657	\$43,657	82.82%	
	D5010 Electrical Service and Distribution			0			NIC
	D5020 Lighting and Branch Wiring			0			NIC
	D5030 AV Communications			43,657			
	D5090 Other Electrical Systems			0			NIC
E	Equipment and Furnishings				\$0	0.00%	NIC
E10	Equipment			\$0			NIC
	E1010 Commerical Equipment			0			NIC
	E1020 Institutional Equipment			0			NIC
	E1030 Vehicular Equipment			0			NIC
	E1090 Other Equipment			0			NIC
E20	Furnishings			\$0			NIC
	E2010 Fixed Furnishings			0			NIC
	E2020 Movable Furnishings			0			NIC
F	Special Construction & Demolition				\$0	0.00%	NIC
F10	Special Construction			\$0			NIC
	F1010 Special Structures			0			NIC
	F1020 Integrated Construction			0			NIC
	F1030 Vehicular Equipment			0			NIC
	F1040 Special Facilities			0			NIC
	F1050 Special Controls and Instrumentation			0			NIC
F20	Selective Building Demolition			\$0			NIC
	F2010 Building Elements Demolition			0			NIC
	F2020 Hazardous Components Abatement			0			NIC
	Building Total				\$43,657		
Z	General Requirements, General Conditions, Insurance, Bond, & Permit				6,549	15.00%	
	Contractor's Overhead & Profit				2,510	5.00%	
	Subtotal ECC Before Contingencies				\$52,716		
	Contingencies						
	Design Contingency				7,907	15.00%	
	Construction Contingency						Excluded
	Off hour work				6,062	10.00%	
	Escalation Contingency				2,122	3.50%	
	Total ECC with contingencies				\$68,807		
	<i>Total Rate/SF with contingencies</i>						

August 08, 2013

CITY OF CAMBRIDGE
 Cambridge, MA
 AV Upgrades

Architect : LDa Architects, LLP

Portable Video

Code	Description	Quantity	Unit	Rate	Assembly Cost
A	SUBSTRUCTURE				
A10	FOUNDATIONS				
A1010	Standard Foundations				\$ -
	No items in this section				
A1020	Special Foundations				\$ -
	No items in this section				
A1030	Slab on Grade				\$ -
	No items in this section				
A20	BASEMENT CONSTRUCTION				
A2010	Basement Excavation				\$ -
	No items in this section				
A2020	Basement Walls				\$ -
	No items in this section				
B	SHELL				
B10	SUPERSTRUCTURE				
B1010	Floor Construction				\$ -
	No items in this section				
B1020	Roof Construction				\$ -
B20	ENCLOSURE				
B2010	Exterior Walls				\$ -
	No items in this section				
B2020	Exterior Windows				\$ -
	No items in this section				
B2030	Exterior Doors				\$ -
	No items in this section				
B30	ROOFING				
B3010	Roof Coverings				\$ -
	No items in this section				
B3020	Roof Openings				\$ -
	No items in this section				

August 08, 2013

CITY OF CAMBRIDGE
 Cambridge, MA
 AV Upgrades

Architect : LDa Architects, LLP

Portable Video

C	INTERIORS				
C10	INTERIOR CONSTRUCTION				
C1010	Partitions				\$ -
	No items in this section				
C1020	Interior Doors				\$ -
	No items in this section				
C1030	Fittings				\$ -
	No items in this section				
C20	STAIRS				
C2010	Stair Construction				\$ -
	No items in this section				
C2020	Stair Finishes				\$ -
	No items in this section				
C30	INTERIOR FINISHES				
C3010	Wall Finishes				\$ -
	No items in this section				
C3020	Floor Finishes				\$ -
	No items in this section				
C3030	Ceiling Finishes				\$ -
	No items in this section				
D	SERVICES				
D10	CONVEYING				
D1010	Elevators and Lifts				\$ -
	No items in this section				
D1020	Escalators and Moving Walks				\$ -
	No items in this section				
D1090	Other Conveying Systems				\$ -
	No items in this section				

August 08, 2013

CITY OF CAMBRIDGE
 Cambridge, MA
 AV Upgrades

Architect : LDa Architects, LLP

Portable Video

D20	PLUMBING				
D2010	Plumbing Fixtures				\$ -
	No items in this section				
D2020	Domestic Water Distribution				\$ -
	No items in this section				
D2030	Sanitary Waste				\$ -
	No items in this section				
D2040	Rain Water Drainage				\$ -
	No items in this section				
D2090	Other Plumbing Systems				\$ -
	No items in this section				
D30	HVAC				
D3010	Energy Supply				\$ -
	No items in this section				
D3020	Heat Generating Systems				\$ -
	No items in this section				
D3030	Cooling Generating Systems				\$ -
	No items in this section				
D3040	Distribution Systems				\$ -
	No items in this section				
D3050	Terminal and Package Units				\$ -
	No items in this section				
D3060	Controls and Instrumentation				\$ -
	No items in this section				
D3070	Systems Testing and Balancing				\$ -
	No items in this section				
D3090	Other HVAC Systems and Equipment				\$ -
	No items in this section				
D40	FIRE PROTECTION				
D4010	Sprinklers				\$ -
	No items in this section				

August 08, 2013

CITY OF CAMBRIDGE
 Cambridge, MA
 AV Upgrades

Architect : LDa Architects, LLP

Portable Video

D4020	Standpipes					\$ -
	No items in this section					
D4030	Fire Protection Specialties					\$ -
	No items in this section					
D4090	Other Fire Protection Systems					\$ -
	No items in this section					
D50	ELECTRICAL					
D5010	Electrical Service and Distribution					\$ -
	No items in this section					
D5020	Lighting and Branch Wiring					\$ -
	No items in this section					
D5030	AV Communications					\$ 43,657
	Portable video display panel for Sullivan Chamber or in the Senior Center	2	EA	\$ 6,000.00		12,000
	Portable Projection Screen with Stand	1	EA	\$ 650.00		650
	Video Projector	1	EA	\$ 6,000.00		6,000
	Projector Mount	1	EA	\$ 500.00		500
	Video/Audio Transmission Equipment	1	EA	\$ 1,300.00		1,300
	Wireless Microphone Systems (Existing)					ETR
	Wired Microphones with Stands	2	EA	\$ 300.00		600
	Portable Powered Loudspeaker	2	EA	\$ 700.00		1,400
	Loudspeaker Stands	2	EA	\$ 150.00		300
	Assistive Listening System	1	EA	\$ 900.00		900
	Video/Audio Routing Equipment	1	EA	\$ 6,000.00		6,000
	AV Control Panel	1	EA	\$ 1,300.00		1,300
	Castered Equipment Rack/Road Case	1	EA	\$ 2,000.00		2,000
	Miscellaneous Hardware & Cable	1	EA	\$ 1,500.00		1,500
	Installation of above	1	EA	\$ 7,858.00		7,858
	Control System Programming	1	EA	\$ 449.00		449
	Additional Projection Screen	1	EA	\$ 900.00		900
D5090	Other Electrical Systems					\$ -
	No items in this section					

August 08, 2013

CITY OF CAMBRIDGE
 Cambridge, MA
 AV Upgrades

Architect : LDa Architects, LLP

Portable Video

E	EQUIPMENT & FURNISHINGS				
E10	EQUIPMENT				
E1010	Commercial Equipment				\$ -
	No items in this section				
E1020	Institutional Equipment				\$ -
	No items in this section				
E1030	Vehicular Equipment				\$ -
	No items in this section				
E1090	Other Equipment				\$ -
	No items in this section				
E20	FURNISHINGS				
E2010	Fixed Furnishings				\$ -
	No items in this section				
E2020	Movable Furnishings				\$ -
	No items in this section				
F	SPECIAL CONSTRUCTION & DEMOLITION				
F10	SPECIAL CONSTRUCTION				
F1010	Special Structures				\$ -
	No items in this section				
F1020	Integrated Construction				\$ -
	No items in this section				
F1030	Vehicular Equipment				\$ -
	No items in this section				
F1040	Special Facilities				\$ -
	No items in this section				
F1050	Special Controls and Instrumentation				\$ -
	No items in this section				
F20	SELECTIVE BUILDING DEMOLITION				
F2010	Building Elements Demolition				\$ -
	No items in this section				

August 08, 2013

CITY OF CAMBRIDGE
Cambridge, MA
AV Upgrades

Architect : LDa Architects, LLP

Portable Video

F2020	Hazard Components Abatement				\$ -
	No items in this section				

CITY OF CAMBRIDGE

AUDIOVISUAL RENOVATIONS

Preliminary Audiovisual Systems Program

June 24, 2013

TABLE OF CONTENTS

1.	GENERAL SUMMARY	3
2.	INTRODUCTION	3
3.	SULLIVAN CHAMBER	6
4.	ACKERMANN ROOM	11
5.	SOPHIE J. ANASTOS ROOM	13
6.	MEETING ROOM, BASEMENT, LOMBARDI BUILDING	14
7.	MULTIPURPOSE ROOM – SENIOR CENTER	16
8.	COMMUNITY ROOM – CITY HALL ANNEX	19
9.	MEETING AREA – WATER DEPARTMENT	21
10.	PORTABLE AUDIOVISUAL SYSTEM	22
11.	EQUIPMENT CUTS	23

GENERAL SUMMARY

1.0 **GENERAL:**

The renovated spaces for the City of Cambridge at City Hall, the Cambridge Senior Center, and other buildings include a number of rooms requiring audiovisual presentation and, in some cases, video production for Cambridge City Television. The audiovisual technology design will provide for installation of new equipment, with the reuse of certain equipment where appropriate. The audiovisual technology will be designed to present a uniform and user-friendly interface in order to enable easy use of the systems by as wide a group of users as possible.

1.1 **ACENTECH'S BACKGROUND**

Acentech is an independent consulting firm specializing in the design of advanced sound, audiovisual and videoconferencing systems. In order to provide unbiased consulting and design services, Acentech does not sell or install equipment and does not represent any dealer, distributor, or manufacturer.

INTRODUCTION

2.0 **INFRASTRUCTURE VS. EQUIPMENT:**

The distinction between infrastructure and equipment must be emphasized:

Infrastructure is part of the building construction and includes conduit, raceways, junction and device boxes, as well as electrical power and grounding required exclusively for audiovisual systems cabling and equipment. Properly designed AV infrastructure allows for not only the installation of the initially specified equipment, but for the evolution of the systems over many years. If proper infrastructure is provided, additional capabilities and equipment can be efficiently added later as technology progresses.

Equipment refers to the devices that can be connected through the infrastructure. Equipment includes microphones, loudspeakers, mixers, signal processing gear, video projectors, flat-panel displays, cameras, VCRs, DVD players, AV control systems, patch bays, equipment racks, and many other devices that comprise an AV system, including cabling interconnections to AV devices.

One thing is certain; equipment will continue to change over the life of the room as user needs and technology change. For this reason, a properly designed infrastructure is the key to the long-term success of a thoughtfully conceived AV design project because it governs what can and cannot be easily installed in the future.

2.1 **EQUIPMENT NOTES AND DEFINITIONS:**

This report is not a technical specification and is insufficient to bid or build an AV system. Except where useful to illustrate a standard of performance or a specific user requirement, equipment manufacturers and model numbers are not used.

Permanently-installed refers to equipment that will be part of the room systems and cannot easily be removed for use elsewhere.

Portable refers to equipment that will be available for connection at one or more locations, but will be not hard-wired to the system. Portable equipment can be disconnected by the user or technical personnel and stored or used with systems elsewhere in the facility.

OFE (Owner Furnished Equipment) refers to equipment that will be either already owned, or may be purchased in the future as needs arise.

2.2 **GENERAL TECHNOLOGY OVERVIEW**

At this time audiovisual systems have begun a transition from analog-formatted signals to an all digital system. While there is some need to maintain compatibility and usability between both the analog and digital worlds, the transition is proceeding and the analog “sundown” (the discontinued use of analog video signals) is fast approaching.

Lighting: Spaces in which video cameras will be used (Sullivan Chamber, Senior Center Multipurpose Room, and the Ackermann Room) must have lighting systems designed to provide good video pickup of people and faces. This requires lighting of vertical surfaces (e.g. faces), relatively high light levels (>30 fc), and a consistent color temperature (ideally 3200 K).

2.3 **PRESENTATION SYSTEMS:**

Presentation systems are the source, routing, and display devices that provide highly intelligible communication of speech, music, information, and graphics to groups of people. This includes equipment such as microphones, loudspeakers, video projectors, flat-panel displays, DVD players, computers, and the interfacing, mixing, routing and control equipment that connects these devices together and allows the user to select the appropriate sources and operate the system.

2.4 **BROADCAST SYSTEMS:**

Broadcast quality equipment and systems generally refer to audio and video devices (cameras, video recorders and editing equipment) of the highest quality, specifically designed for the recording, editing, and production at the commercial level, such as in cable and network television studios. We understand that the existing system in the Sullivan Chamber should be upgraded to current digital technology. Also, it would be desirable to enable live broadcast of events in the multipurpose room in the Senior Center. While a direct connection to CCTV is

possible, the least-cost solution may be to provide a connection via the video production system serving the Sullivan Chamber. This will be supported by a fiber optic link to be installed between the Senior Center and City Hall.

2.5 ASSISTIVE LISTENING SYSTEMS:

Permanently installed Assistive Listening Systems (ALS) are required by the ADA (American with Disabilities Act), a 1990 federal law (2010 update) that forbids discrimination against persons who are hearing handicapped. ALS systems are required in rooms that include permanently installed sound systems and the content (voice and program) is part of the transmission of information. In smaller conference rooms, ALS will be provided using the existing portable ALS equipment. An audio output will be provided for connection of this portable equipment.

2.6 AUDIOVISUAL CONTROL SYSTEMS:

Audiovisual control systems used in these facilities may be as simple as the handheld display control for very simple systems to more integrated control panels for the more complicated room systems.

Audiovisual control systems can be used to unify and simplify the operation of the various functions of the AV system. This will include in certain spaces environmental controls such as lighting presets and shade and drape controls, as well as audiovisual functions such as system and projector power, source selection and media transport controls, volume controls, and many other operational functions identified by the design team before the equipment will be installed.

Advanced functions of the AV control system include multi-level password protection for system operation to prevent unauthorized use, control of automatic system shut-down sequences (to reduce unnecessary wear and tear), and a help system interface for user experiencing technical problems.

2.7 CONTROL SYSTEM MANAGEMENT NETWORK:

Networked AV management systems automate and streamline many technical support functions. Built-in reporting provides the ability to track resource usage for more effective purchasing, scheduling and resource allocation. These systems can reduce response times for service calls and technical supports issues, because system users and presenters can send help requests directly from the touch panels. Technicians can respond with built-in instant messaging, then service and control devices remotely.

SULLIVAN CHAMBER

3.0 **EXECUTIVE SUMMARY:**

This space is currently equipped with an older speech amplifications system and an analog video production system run by Cambridge City Television (CCTV). This system is obsolete and will be replaced. Also, a presentation system using current technology will be installed.

3.1 **OBSERVATIONS AND EXISTING CONDITIONS:**

The existing speech reinforcement system uses four large loudspeakers located on the walls in the corners of the room. These loudspeakers provide poor intelligibility because they are poorly located and have very little control of the directionality of the sound, resulting in an excessively reverberant sound quality. There are currently no loudspeakers serving the mezzanine area.

The existing video production system uses “box” cameras with remotely-controlled lenses and pan/tilt mounts at four locations on the walls of the chamber. These cameras are visually bulky and provide analog video signals, which have become obsolete with the changeover to digital television broadcasting. The entire video system is analog-based and must be replaced to bring the system to the current standards.

There is currently no video presentation system serving the chamber, aside from a video monitor outside the main entrance door.

3.2 **RECOMMENDATIONS:**

- A. *Video Display:* A large electric roll-down projection screen will be provided above and behind the dais to allow viewing of video images for most participants in the chamber. This screen will have a wide-screen aspect ratio (16:10 or 16:9) to support current video standards. A high-brightness video projector will be located at the rear of the room. We anticipate that this will be exposed to view within the room, although this will result in some audible projector noise in the space during system operation.

Because people seated at the dais will not be able to see the screen without turning around and craning their necks, there will be one or two small (17”) video monitors on the dais that will display the same content as is on the screen. These monitors may be mounted below the counter with a glass view port in the counter surface or mounted in a motorized lift that conceals it below the counter except when it is in use. In addition, a pair of LCD flat panel displays will be positioned in the gallery above the opening into the

Chamber to allow spectators in that area to see the displayed image. See Figures 1 and 2.

At the request of the city an LCD display will be provided on a portable cart that will plug into a receptacle at the rear of the room to provide a secondary display for the audience area. In our judgment, the projection screen image will provide satisfactory legibility for the entire room, making the secondary display unnecessary. Therefore, we propose to provide a single display that can be used either in the Sullivan Chamber or in the Senior Center, where a similar display has been requested. It will be possible to purchase a second such display, if desired, following completion of the installation.

- B. *Audiovisual Sources:* A variety of audiovisual sources will be provided in the chamber for a presenter's use which include:
1. A computer (provided by the City) with wireless keyboard and mouse.
 2. A high-resolution document camera for displaying printed material, drawings, and small objects.
 3. A Blu-ray DVD player.
 4. Digital and analog connections for laptop computers. Recent laptop computers are provided with digital video outputs; however, analog inputs will provide support for legacy laptops with VGA connectors.
 5. Connections for portable audio and video equipment.
 6. USB connections to the local computer for portable equipment and memory sticks.
 7. Wireless connectivity for personal computers.
 8. Television programming from CCTV will be provided by one or two tuners in the central control room that can be routed to the room when required.
 9. Streaming media using a computer (provided by the City) as the source device.

We propose that the equipment listed in Items 1-6 above be housed in a castered equipment rack that can be plugged into receptacles in the existing chamber floor box and positioned wherever the presenter desires.

- C. *Video Production (CCTV):* The existing video production will be replaced with a digital production system employing four high-definition (HD) pan/tilt cameras at the existing camera locations. In addition, a fifth camera will be provided (co-located with the rear camera) to give the operators an overall

view of the chamber; this camera view would also be usable as a secondary source for production purposes (typically as an establishing shot of the overall chamber). A character generator, production switcher, pan/tilt controllers, camera/production preview and program monitors, and other necessary equipment will be provided. If a recording capability is required, a Panasonic P2 format recorder will be provided (the existing VHS and DVCAM recorders will be retained for standard definition recording).

D. *Capture/Streaming (OPTION): Rich Media Recording:* Like podcasting, only with video and PowerPoint slides added to it, Rich Media data/video streaming is a technology that allows recording of meetings and presentations for real-time streaming and/or delayed streaming. Streamcasting provides one-way broadcasting of meetings over the Internet, either during the event or at a later time. These recordings would be made using the CCTV video production system. Note that delayed streaming will require that a server be provided on the city network for storage of the content and administration of the streaming function. In general, rich media (RM) technology provides the following functionality:

1. Automatic scheduling, local and remote control of recording start and stop.
2. Digital recording of full-motion video/audio of the presenter(s).
3. Electronically records a high-resolution "snapshot" (low frame rate) images of whatever will be displayed on the local projection screen (e.g., PowerPoint presentation) as it occurs at the event.

E. *Loudspeakers:* The existing loudspeakers in the corners of the chamber will be replaced with a pair of steerable column loudspeakers on either side of the projection screen that will direct the sound toward the listeners and not toward the ceiling and walls of the room where the resulting sound reflections would reduce intelligibility. These loudspeakers will either be recessed into the walls or surface mounted and will be painted to match the stenciled wall pattern. Several small loudspeakers will also be provided for listeners in the gallery; these will be located with the displays above the opening into the Chamber. See Figure 1.

F. *Speech Reinforcement:* Participants at the dais, the councilors' desks and other fixed locations will be provided with wired microphones (the existing microphones will be re-used, unless design decisions dictate that they must be replaced. In addition, three wireless microphone systems will be provided for a presenter who wishes to speak while standing, for members of the audience at the rear of the room, and for audience members in the gallery. Audio mixing and processing (including playback audio) will be provided by a digital audio signal processor that will allow individual microphones to be muted if they are not being used. This processor can

also support audio conferencing, so that someone can participate in a meeting by phone, if desired.

The existing floor boxes will be re-used for connection of microphones at the councilors' desks or at the conference table when the arrangement of the room is changed.

- G. *Assistive Listening System:* A wireless assistive listening system is included in this room to meet the requirements of the Americans with Disabilities Act. Portable receivers will be stored (possibly in the portable rack discussed above) and issued to participants as required. These receivers are for use by the hard-of-hearing (not deaf) participants.
- H. *Video/Audio Routing:* A digital video and computer graphics switch is provided for selection of video sources and transmission to each display (and other destinations, as required). Audio and video functions will be controlled via the touch screen at the portable rack.
- I. *AV Control System:* A control system will be provided to unify and simplify the operation of the audiovisual equipment. A color LCD touch screen at the dais and at the castered equipment rack will be programmed with an intuitive user-friendly graphical user interface (GUI). The control system will be integrated with the existing city data network; to allow technical staff to monitor the operation of the system and to provide technical (help desk) support for users remotely. The audiovisual control system should operate the following:
 - 1. Room lighting presets (via the lighting dimming system, by others). Simple lighting panels should be provided at entry doors as well.
 - 2. Projector display operations (on/off, screen up/down, mute, etc.).
 - 3. DVD playback functions.
 - 4. Video capture operations.
 - 5. Source selection and display.
 - 6. Audio volume levels.
 - 7. Video and audio source selection.
 - 8. Window shade control, if motorized shades are provided.
- J. *Audiovisual Equipment Closet:* The existing CCTV room will be re-used to house the audiovisual equipment.

3.3 **COORDINATION:**

Lighting: The room must have a lighting system to support video production, providing lighting levels of ideally 40-50 vertical footcandles for faces. The color temperature must be uniform, ideally at 3200 K. Ambient lighting on the projection screen should not exceed 7 footcandles. The lighting control system will be interfaced with the AV control system to allow lighting control from the AV control panels. See the lighting narrative.

Acoustics: The room is moderately reverberant, which will affect speech intelligibility to some extent. It is desirable to reduce the reverberation time. See acoustics narrative.

Ambient Light Control: It is necessary to control daylighting for audiovisual presentations during the day and to avoid negative impacts on the video cameras. We recommend the use of window drapes or other light control devices. If drapes of heavy fabric are used, these can provide useful sound absorption to reduce the reverberation time (see above). Motorized daylight control systems are recommended.

Exterior daylighting entering the room can be a major problem for video production when the drapes or shades are open, since the video cameras will close their iris when the bright windows are in the field of view of the camera, causing the people in the room to become very dark. This problem can be dealt with by using a system employing a polarizing film applied to the windows and polarizing filters on the cameras. This system will allow the brightness of the windows as seen by the cameras to be controlled to give a good balance between window brightness and the brightness of other parts of the room. The window film has a minimal impact on the perceived window brightness for room occupants.

Anticipated Electrical Load: The electrical load for the audiovisual equipment in the room is not expected to exceed 12,000 watts. A more detailed breakdown will be made as the project progresses.

Architectural: Installation of some AV equipment will require securing devices to the walls, installing conduit in walls, and possible cutting of the walls to accommodate projectors and/or loudspeakers.

Delayed Streaming: If a delayed (on-demand) streaming capability is desired, there will need to be a computer server provided by the city or CCTV to store and forward the content.

ACKERMANN ROOM

4.0 EXECUTIVE SUMMARY:

This meeting room in City Hall currently has no audiovisual system and is to be equipped with an audiovisual presentation system. In addition, we propose that this system support videoconferencing, to provide one room in City Hall with such a capability.

4.1 OBSERVATIONS AND EXISTING CONDITIONS:

The room is approximately square, with a conference table taking up one half of the room. This layout works well for many types of meetings but there is no existing support for audiovisual presentations. The windows currently have manually operated shades for light control. These are adequate for light control for audiovisual presentations.

4.2 RECOMMENDATIONS:

- A. *Video Display:* A 70" flat-panel display will be provided at the wall at one end of the conference table. Because the walls of the room are paneled, we propose that the display be placed on a custom-designed credenza, rather than mounted to the wall; the credenza will also provide a location for storage of the electronic equipment. See Figure 3.
- B. *Audiovisual Sources:* Portable equipment, such as laptop computers, will be connected to the display at a table box in the conference table. This box will also provide power and data connections.
- C. *Audio Conferencing:* A conference telephone will be provided on the table to support audio calls. This phone will also provide the audio portion of videoconference calls (see below).
- D. *Videoconferencing:* A videoconference codec will be provided, along with a camera mounted on the flat panel display to support video calls. Audio support will be provided by the conference phone on the table (see above). The codec will be connected to the public Internet for connection to other sites.
- E. *Audio Systems:* Loudspeakers will be provided at the flat panel display for playback of audio from source equipment connected to the system.
- F. *Assistive Listening System:* A connection will be provided to allow the City's portable assistive listening system to be connected, providing support for the hearing-impaired.

- G. *Video/Audio Routing:* A basic video and audio routing system will be provided.
- H. *AV Control System:* A control system will be provided to unify and simplify the operation of the audiovisual equipment. A button-type control panel at the credenza will be provided for system control. The control system will be integrated with the existing city data network; to allow technical staff to monitor the operation of the system and to provide technical (help desk) support for users remotely. The audiovisual control system will operate the following:
1. Video display operations (on/off, source select, etc.).
 2. Audio volume levels.
 3. Lighting system, if a controllable system is provided.

The videoconference system will be controlled using the wireless remote control that comes with the system.

- K. *Millwork:* A custom-designed credenza will be provided to house the AV equipment and to serve as a base to support the video display.

4.3 **COORDINATION:**

Lighting: The room must have a lighting system to support video conferencing, providing lighting levels of ideally 40-50 vertical footcandles for faces. The color temperature must be uniform, ideally at 3200 K. If an architectural lighting control system is provided, it will be interfaced with the AV control system to allow lighting control from the AV control panel. See lighting narrative.

Acoustics: It is desirable to improve the acoustic ceiling treatment to provide more absorption to provide a good environment for videoconferencing and audio calls. See acoustics narrative.

Anticipated Electrical Load: The electrical load for the audiovisual equipment in the room is not expected to exceed 4,000 watts. A more detailed breakdown will be made as the project progresses.

Architectural: Wiring to the conference table will require a new floor box under that table and conduit.

SOPHIE J. ANASTOS ROOM

5.0 EXECUTIVE SUMMARY:

This meeting room in City Hall currently is equipped with an audiovisual presentation system that is not easy to use and does not support digital sources. We recommend that the system be largely replaced to have functionality similar to the Ackermann Room, discussed above, except for the omission of videoconferencing.

5.1 OBSERVATIONS AND EXISTING CONDITIONS:

This meeting room in City Hall currently is equipped with an audiovisual presentation system. However, this system has several drawbacks: The screen is in the corner of the room, making viewing awkward for people seated on the same side of the table, the system does not support digital sources, and ease of use of the control system needs to be improved. The window air conditioner provides an objectionably high level of background noise. Lighting is adequate.

5.2 RECOMMENDATIONS:

- A. *Video Display:* A 70" flat-panel display will be provided in the front of the room. Because the window makes placement of the screen on the table centerline impossible, we propose to mount the screen in the corner of the room on a custom sliding mount to allow it to be pulled out in front of the window and centered on the table when it is used, providing a good view for all people at the table. See Figure 4.
- B. *Audiovisual Sources:* Portable equipment, such as laptop computers, will be connected to the display at an existing table box in the conference table. This box will also provide power and data connections.
- C. *Audio Conferencing:* A conference telephone will be provided on the table to support audio calls.
- D. *Audio Systems:* Loudspeakers will be provided at the flat panel display for playback of audio from source equipment connected to the system.
- E. *Assistive Listening System:* A connection will be provided to allow the City's portable assistive listening system to be connected, providing support for the hearing-impaired.
- F. *Video/Audio Routing:* A basic video and audio routing system will be provided.

G. *AV Control System:* A control system will be provided to unify and simplify the operation of the audiovisual equipment. A button-type control panel at the credenza will be provided for system control. The control system will be integrated with the existing city data network; to allow technical staff to monitor the operation of the system and to provide technical (help desk) support for users remotely. The audiovisual control system will operate the following:

1. Video display operations (on/off, source select, etc.).
2. Audio volume levels.

H. *Millwork:* The existing equipment cabinet at the side of the room will house the AV equipment.

5.3 **COORDINATION:**

Lighting: We do not anticipate that the lighting control system will be interfaced with the AV control system to allow lighting control from the AV control panel. See lighting narrative.

Acoustics: The current sound absorptive treatment in the room is adequate. We recommend that the window air conditioner be replaced to reduce ambient noise when cooling is required. See acoustics narrative.

Ambient Light Control: Once the window air conditioner is relocated, it will be necessary to provide a manually operated room-darkening shade at the window,.

Anticipated Electrical Load: The electrical load for the audiovisual equipment in the room is not expected to exceed 3,000 watts. A more detailed breakdown will be made as the project progresses.

Architectural: Wiring to the wall-mounted LCD display will require new conduit.

MEETING ROOM, BASEMENT, LOMBARDI BUILDING

6.0 **EXECUTIVE SUMMARY:**

This meeting room in the Lombardi Building adjacent to City Hall currently is equipped with a speech reinforcement system. We propose that this audio system be retained and a video projector and manual projection screen be added to provide a video presentation capability.

6.1 **OBSERVATIONS AND EXISTING CONDITIONS:**

This meeting room has a very low acoustic tile ceiling and a moderately high level of ambient noise. If the noise levels were lower, the existing speech reinforcement would not be required.

6.2 **RECOMMENDATIONS:**

- A. *Video Display:* A wall-mounted 57.5"x92" manual roll-down projection screen will be provided in the front of the room with a ceiling-mounted video projector. See Figure 5.
- B. *Audiovisual Sources:* Portable equipment, such as laptop computers, will be connected to the display at a new wall-mounted input panel.
- C. *Audio Conferencing:* A conference telephone will be provided on the table to support audio calls.
- D. *Audio Systems:* The existing loudspeakers and amplifier will be retained for speech reinforcement and for playback of audio from source equipment connected to the system.
- E. *Assistive Listening System:* A connection will be provided to allow the City's portable assistive listening system to be connected, providing support for the hearing-impaired.
- F. *Video/Audio Routing:* A basic video and audio routing system will be provided.
- G. *AV Control System:* A control system will be provided to unify and simplify the operation of the audiovisual equipment. A button-type control panel at the credenza will be provided for system control. The control system will be integrated with the existing city data network; to allow technical staff to monitor the operation of the system and to provide technical (help desk) support for users remotely. The audiovisual control system will operate the following:
 - 1. Video display operations (on/off, source select, etc.).
 - 2. Audio volume levels.
- H. *Millwork:* The existing equipment cabinet will house the AV equipment.

6.3 **COORDINATION:**

Lighting: We do not anticipate that the lighting control system will need to be interfaced with the AV control system to allow lighting control from the AV control panel. See lighting narrative.

Acoustics: The current sound absorptive treatment in the room is adequate. We recommend that the steps be taken to reduce the level of mechanical system noise. See acoustics narrative.

Anticipated Electrical Load: The electrical load for the audiovisual equipment in the room is not expected to exceed 3,000 watts. A more detailed breakdown will be made as the project progresses.

MULTIPURPOSE ROOM – SENIOR CENTER

7.0 **EXECUTIVE SUMMARY:**

The existing audiovisual system serving this room is of poor quality. We recommend that, with the exception of the screen on the west wall of the room, that the entire system be replaced and that the system be expanded to provide support for audiovisual presentations as well as better support for video production (better lighting and a link via City Hall for live video production).

7.1 **OBSERVATIONS AND EXISTING CONDITIONS:**

This flat-floor room is divisible into two smaller east and west rooms of unequal size using an operable wall. The existing speech reinforcement is of poor quality and the excessive levels of HVAC system noise reduces its effectiveness further. There is an existing projection screen in the smaller (west) side of the room; but, otherwise, there is no built-in audiovisual capability. The room is currently used periodically by CCTV for video recording; it would be desirable to be able to broadcast live from there. A video display capability is needed, including display of motion pictures on DVDs and videotapes. The existing very large pendent light fixtures conflict with the use of ceiling-mounted video projectors and should be replaced.

The existing ceiling loudspeaker are two far apart to provide uniform coverage of the room. That, and the high level of mechanical system noise, are the basis of the large number of complaints concerning hearing difficulties.

7.2 **RECOMMENDATIONS:**

- A. *Video Display:* A 72.5"x116" electric roll-down projection screen will be provided at the east wall of the room, and the existing screen on the west wall will be retained. Two ceiling-mounted video projectors will be provided, one to serve each projection screen, providing a display capability for each side of the room. See Figure 6.

The city has requested that an LCD display with a portable cart be provided

to allow better viewing at the rear of the multipurpose room or in the dining area, should that be opened up to the main multipurpose room. As discussed for the Sullivan Chamber, we propose to specify a single display that can be used in either area; however, we believe that it would be primarily useful in the Senior Center.

- B. *Audiovisual Sources:* A variety of audiovisual sources will be provided in the room which include:
1. A VCR/DVD combo player located in the existing equipment room to serve either video projector.
 2. Wall-mounted digital connections for laptop computers brought in by users in both rooms. Note an analog VGA connection will also be provided.
 3. Connections for portable audio and video equipment in both rooms.
- C. *Speech Reinforcement:* Two wireless microphone systems will be available for presenter use (one for each room). These systems will be provided with both a lavalier-type and handheld transmitter to allow for choice by the users. Speech audio will be reproduced through the existing ceiling loudspeakers, supplemented by additional loudspeakers to reduce the spacing between loudspeakers by 50%.
- D. *Audio Systems:* All audio will be managed by a digital processor capable of automatically mixing and processing each input and output for optimal performance. Stereo playback loudspeakers will be provided at the projection screens for playback of audio soundtracks.
- E. *Assistive Listening System:* A wireless assistive listening system is included for each room to meet the requirements of the Americans with Disabilities Act. Portable receivers will be stored centrally and issued to participants as required. These receivers are for use by the hard-of-hearing (not deaf) listeners.
- F. *Video/Audio Routing:* A digital video and computer graphics switch are provided for selection of video sources and transmission to each display (and other destinations, as required). Audio and video functions will be controlled via the wall-mounted touch screen.
- G. *AV Control System:* A control system will be provided to unify and simplify the operation of the audiovisual equipment. A color LCD touch screen will be programmed with an intuitive user-friendly graphical user interface (GUI). The control system will be integrated with the existing city data network; to allow technical staff to monitor the operation of the system and to provide

technical (help desk) support for users remotely. The audiovisual control system will operate the following:

1. Room lighting presets (via the lighting control system, by others).
2. Projector display operations (on/off, screen up/down, mute, etc.).
3. Source selection and display.
4. Audio volume levels.
5. Video and audio source selection.

H. *Video Production Support:* Support will be provided for live broadcast of events over CCTV by providing an input from portable video production equipment (composite video and high-definition digital video). This input will be connected to the CCTV control room at the Sullivan Chamber using an existing fiber connection between the two buildings for transmission to the CCTV main studio.

7.3 **COORDINATION:**

Lighting: The room must have a lighting system to support video production, providing lighting levels of ideally 40-50 vertical footcandles for faces. The color temperature must be uniform, ideally at 3200 K. Ambient lighting on the projection screens should not exceed 7 footcandles. The lighting control system will be interfaced with the AV control system to allow lighting control from the AV control panels. See lighting narrative.

Acoustics: The mechanical system serving the room is very noisy and interferes with the intelligibility of the sound system. Noise levels must be reduced. See acoustics narrative.

Ambient Light Control: There are existing manually-controlled blinds on the windows, which are not very effective in reducing daylight for projection purposes as well as for video production. Replacing them with more effective light control is desirable. Total blackout is not required; motorized operation may be desirable.

Anticipated Electrical Load: The electrical load for the audiovisual equipment in the room is not expected to exceed 7,000 watts. A more detailed breakdown will be made as the project progresses.

Architectural: Installation of some AV equipment (screens, projectors, loudspeakers, etc.) will require alterations to the ceiling.

COMMUNITY ROOM – CITY HALL ANNEX

8.0 EXECUTIVE SUMMARY:

This room is currently equipped with an overly elaborate audiovisual presentation system that is so difficult to operate that it is rarely used. The system will be re-designed to be more appropriate for the uses of the room and much easier for users to operate. The system will also be upgraded to support digital sources. Some of the equipment in this system is of good quality and will be re-purposed for other spaces that are part of this project.

8.1 OBSERVATIONS AND EXISTING CONDITIONS:

The system serving this space is extremely complex, with many wired and wireless microphones, complex video and audio routing, a video production system that apparently has never been used, and a control system that is not easy to use. In addition, the city does not have a copy of the audiovisual system software and therefore cannot easily modify or repair the program. In addition, the video projector does not support digital video sources. This system needs to be greatly simplified to provide a more appropriate level of functionality.

8.2 RECOMMENDATIONS:

- A. *Video Display:* The existing electric roll-down projection screen will be retained for use with a new video projector that supports digital video sources.
- B. *Audiovisual Sources:* A variety of audiovisual sources will be provided in the room and for a presenter's use which include:
 - 1. Blu-ray DVD player.
 - 2. Digital connections for laptop computers. Note an analog VGA connection will also be provided.
 - 3. Connections for portable audio and video equipment.
- C. *Speech Reinforcement:* The existing loudspeakers will be provided with wired microphones and a pair of wireless microphones (the existing microphones will be re-used).
- D. *Audio Systems:* All audio will be managed by a digital processor capable of automatically mixing and processing each input and output for optimal performance. The existing ceiling loudspeakers will be used for speech and playback audio.

- E. *Assistive Listening System:* A wireless assistive listening system is included in this room to meet the requirements of the Americans with Disabilities Act. Portable receivers will be stored centrally and issued to participants as required. These receivers are for use by the hard-of-hearing (not deaf) students.
- F. *Video/Audio Routing:* A digital video and computer graphics switch are provided for selection of video sources and transmission to each display (and other destinations, as required). Audio and video functions will be controlled via the touch screen.
- G. *AV Control System:* A control system will be provided to unify and simplify the operation of the audiovisual equipment. A touchpanel control panel at the lectern will be programmed for the required control functions. The control system will be integrated with the existing city data network; to allow technical staff to monitor the operation of the system and to provide technical (help desk) support for users remotely. The audiovisual control system will operate the following:
 - 1. Room lighting presets (via the lighting dimming system, by others).
 - 2. Projector display operations (on/off, screen up/down, mute, etc.).
 - 3. Source selection and display.
 - 4. Audio volume levels.
 - 5. Video and audio source selection.

8.3 **COORDINATION:**

Lighting: The existing room lighting system is adequate and can be retained.

Acoustics: The mechanical system serving the room is very noisy and interferes with the intelligibility of the sound system. Noise levels must be reduced.

Ambient Light Control: There are existing manually-controlled blinds on the windows, providing adequate control of daylight.

Anticipated Electrical Load: The electrical load for the audiovisual equipment in the room is not expected to exceed 5,000 watts. A more detailed breakdown will be made as the project progresses.

MEETING AREA – WATER DEPARTMENT

9.0 EXECUTIVE SUMMARY:

The entry area at the water department at Fresh Pond is frequently used for assemblies too large for the one remaining conference room (the original conference/training room has been taken over to serve as an Emergency Operations Center). Because of the large amount of glazing in this space, there will not be a video display capability as a permanent part of the system (the portable system discussed below will be suitable for use here when video presentation is needed). A permanent speech reinforcement system will be provided.

9.1 OBSERVATIONS AND EXISTING CONDITIONS:

The entry area at the water department at Fresh Pond has no acoustic treatment and the long reverberation time makes intelligibility very poor with the temporary sound systems currently used in the space. There is some intrusive noise from the adjacent pump room; however, this will not prevent intelligible speech reinforcement using a suitable sound system.

9.2 RECOMMENDATIONS:

- A. *Speech Reinforcement:* A speech reinforcement system will be provided using a steerable column loudspeaker system, similar to that proposed for the Sullivan Chamber. This system will provide good intelligibility, even in the somewhat reverberant acoustic conditions that are likely to prevail. A wireless microphone system and receptacles for wired microphones will also be provided. See Figure 7.
- B. *Assistive Listening System:* A connection will be provided to allow the City's portable assistive listening system to be connected, providing support for the hearing-impaired.
- C. *AV Control System:* A basic control system with a button-type control panel will be provided to provide control for audio levels with a wall-mounted control panel.

9.3 COORDINATION:

Acoustics: Absorptive treatment should be added to available room surfaces to reduce reverberation.

Anticipated Electrical Load: The electrical load for the audiovisual equipment in the room is not expected to exceed 1,000 watts. A more detailed breakdown will be made as the project progresses.

PORTABLE AUDIOVISUAL SYSTEM

10.0 DESCRIPTION:

This portable system is intended to provide support for meetings including audiovisual presentations in spaces that are not equipped for speech reinforcement and/or video presentation. It will be housed in transportable cases or racks to allow it to be transported easily with a minimum possibility of damage to the equipment, as well as to minimize setup difficulty and time. At the Water Department, this system may be used after dark when video presentations are required.

10.1 RECOMMENDATIONS:

- A. *Video Display:* A portable projection screen and video projector will be provided. The video projector will be mounted on the equipment cart will height adjustment that will allow the cart to serve as a stand for the projector when it is in use.
- B. *Audiovisual Sources:* Audiovisual sources will include.
 - 1. A VCR/Blu-ray DVD combo player.
 - 2. Input for portable audio equipment such as iPods.
 - 3. Digital connections for laptop computers. Note an analog VGA connection will also be provided.
 - 4. Connections for portable audio and video equipment.
- C. *Speech Reinforcement:* Two wireless microphone systems will be provided with lavalier and handheld transmitters for flexibility of use. Two wired microphones and an audio mixer will also be included.
- D. *Loudspeaker Systems:* Two portable powered loudspeakers with speaker stands will be included. For small speech-only events these loudspeakers can be used without the equipment rack.
- E. *Assistive Listening System:* A wireless assistive listening system is included as part of the system to meet the requirements of the Americans with Disabilities Act. Portable receivers will be stored in the equipment rack and issued to participants as required. These receivers are for use by the hard-of-hearing (not deaf) listeners.
- F. *Video/Audio Routing:* A digital video and computer graphics switch is provided for selection of video sources and transmission to the projector.

G. *AV Control System:* A basic control system will be provided to unify and simplify the operation of the audiovisual equipment. A control panel will be provided for microphone control. VCR/DVD control functions will be provided by the manufacturer's wireless control.

1. Projector display operations (on/off, screen up/down, mute, etc.).
2. Source selection and display.
3. Audio volume levels.
4. Video and audio source selection.

H. *Equipment Rack:* An equipment rack shock-mounted in a castered road case will be provided. This rack will house all equipment except for the loudspeakers, projection screen, and their stands, and will also serve as the stand for the video projector.

10.2 COORDINATION:

Anticipated Electrical Load: The electrical load for the audiovisual equipment in the room is not expected to exceed 1,000 watts. A more detailed breakdown will be made as the project progresses.

EQUIPMENT CUTS

11.0 DESCRIPTION:

The following are cuts of major items of equipment that are anticipated to be part of the audiovisual systems. In certain cases, the specific cuts provided are intended to serve as an example only—other equivalent products will be specified. In other cases, the equipment is selected specifically as the best choice for the application and no alternates will be accepted.

FIGURE 1: SULLIVAN CHAMBER FRONT WALL VIEW

**EXISTING
LOUDSPEAKER
(TYPICAL)**

**SURFACE-MOUNTED
MOTORIZED VIDEO
PROJECTION SCREEN**

**LOUDSPEAKER
(RECESSED OR
SURFACE-MOUNTED,
TBD)**

**VIDEO DISPLAY
MONITOR**

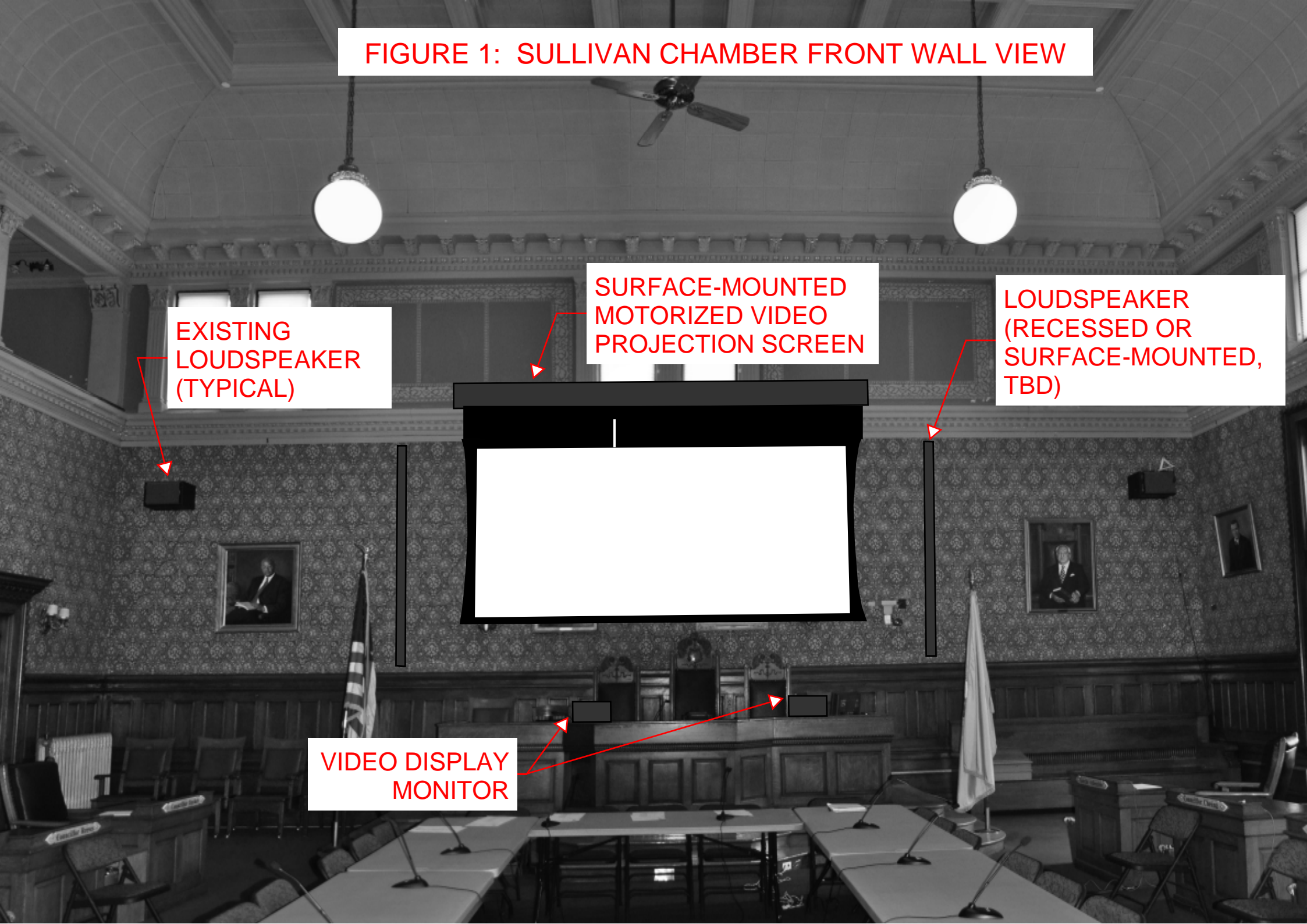


FIGURE 2: SULLIVAN CHAMBER REAR WALL VIEW

VIDEO PROJECTOR
(EXACT HEIGHT TBD)

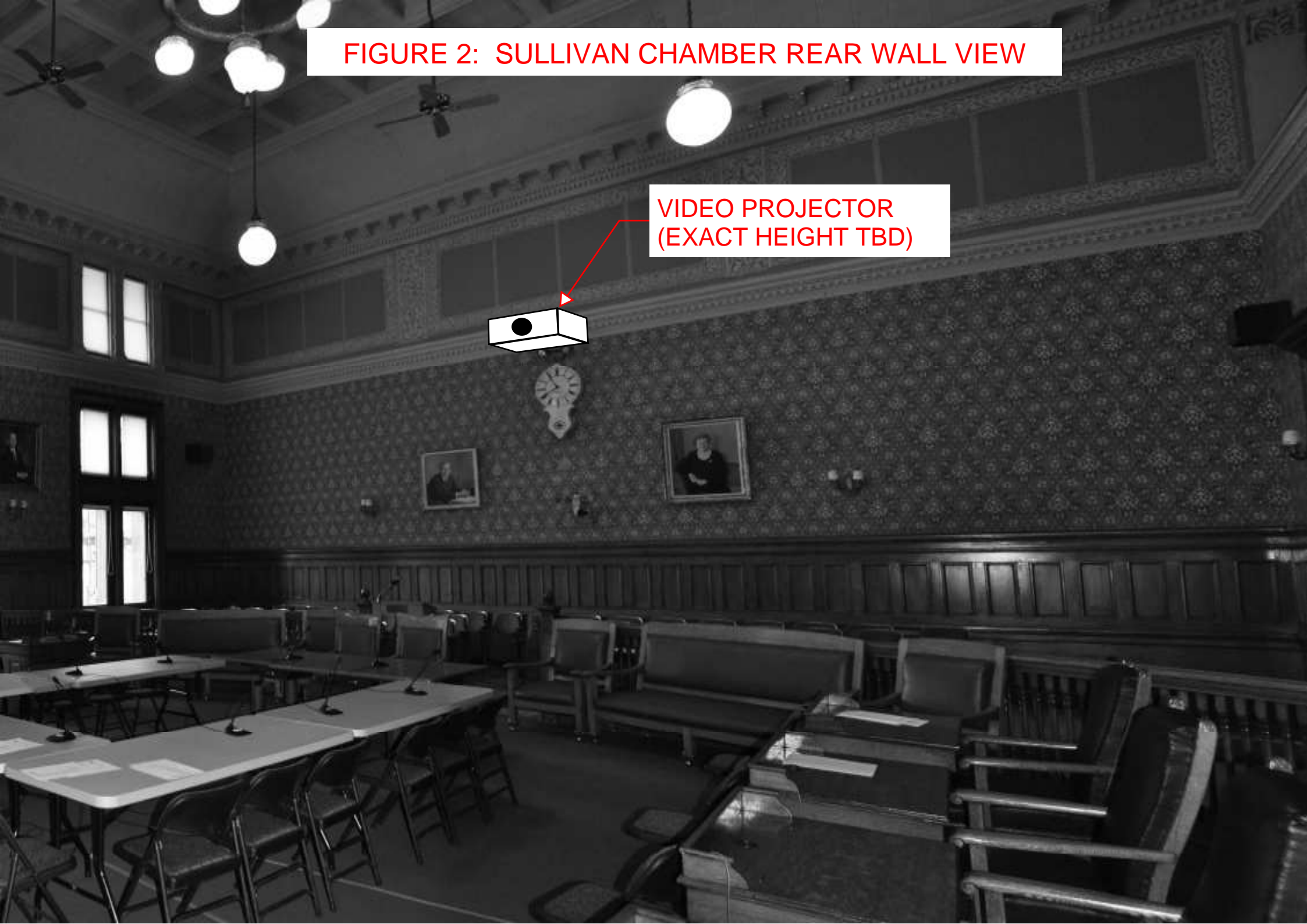
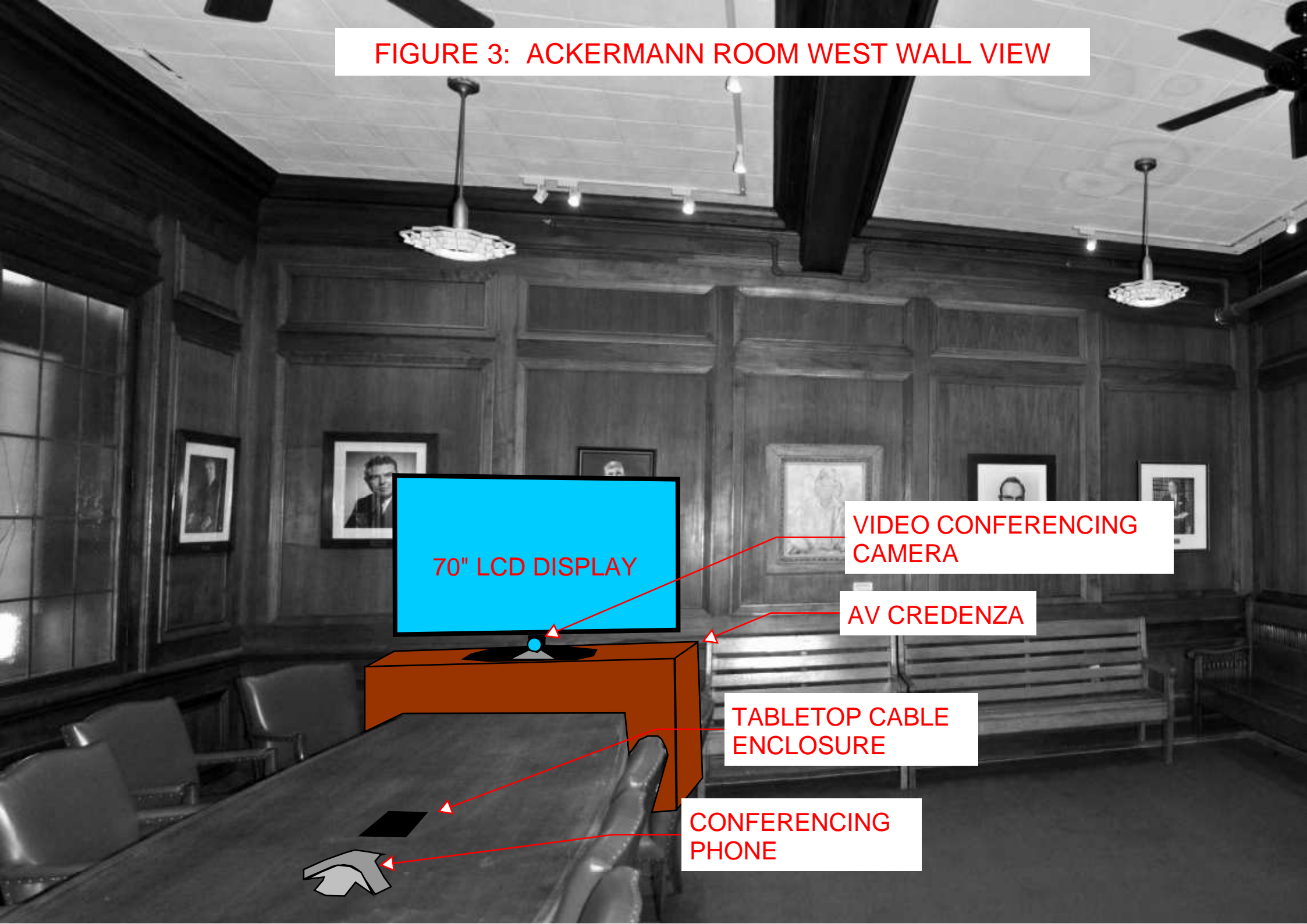


FIGURE 3: ACKERMANN ROOM WEST WALL VIEW



70" LCD DISPLAY

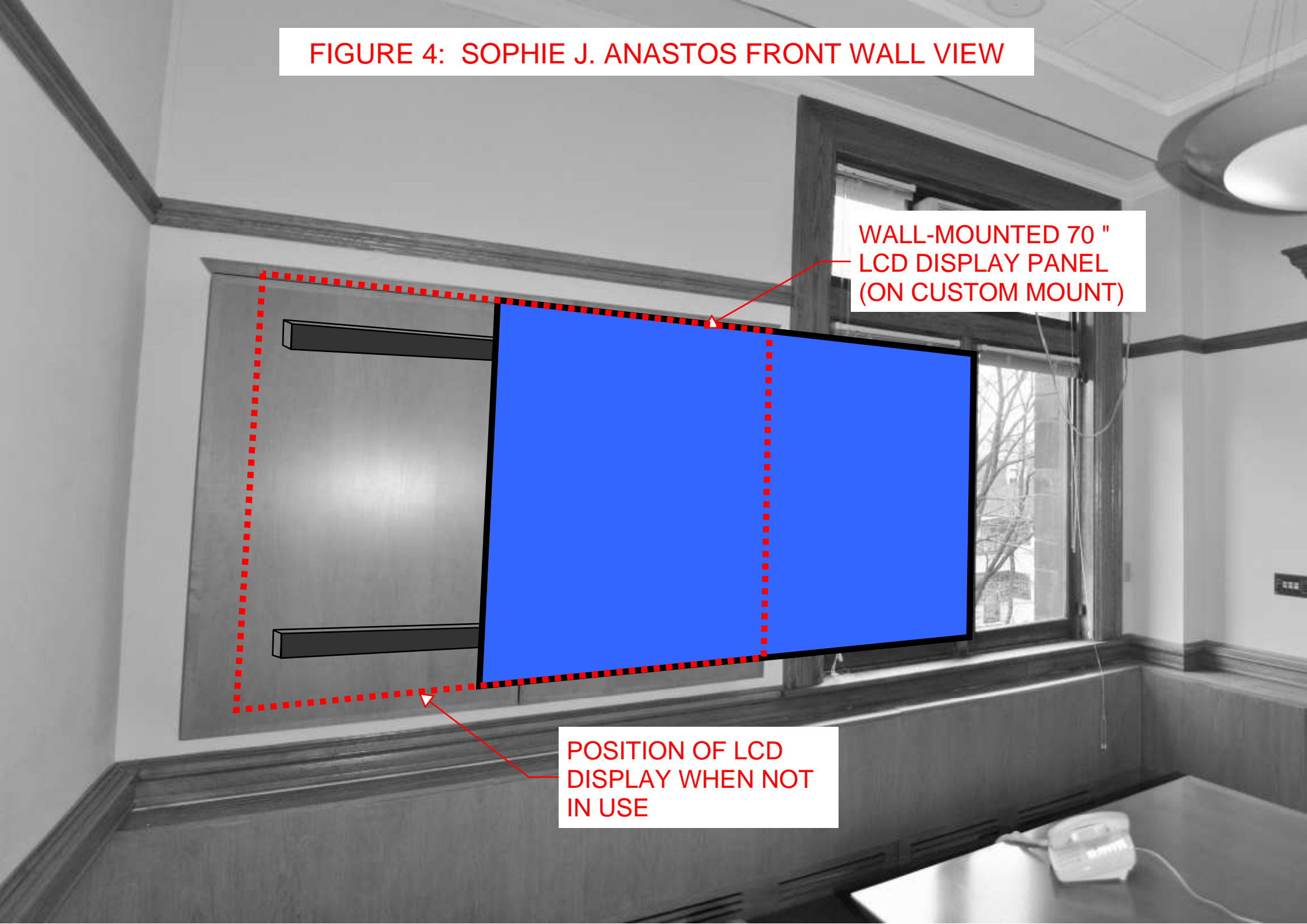
VIDEO CONFERENCING CAMERA

AV CREDENZA

TABLETOP CABLE ENCLOSURE

CONFERENCING PHONE

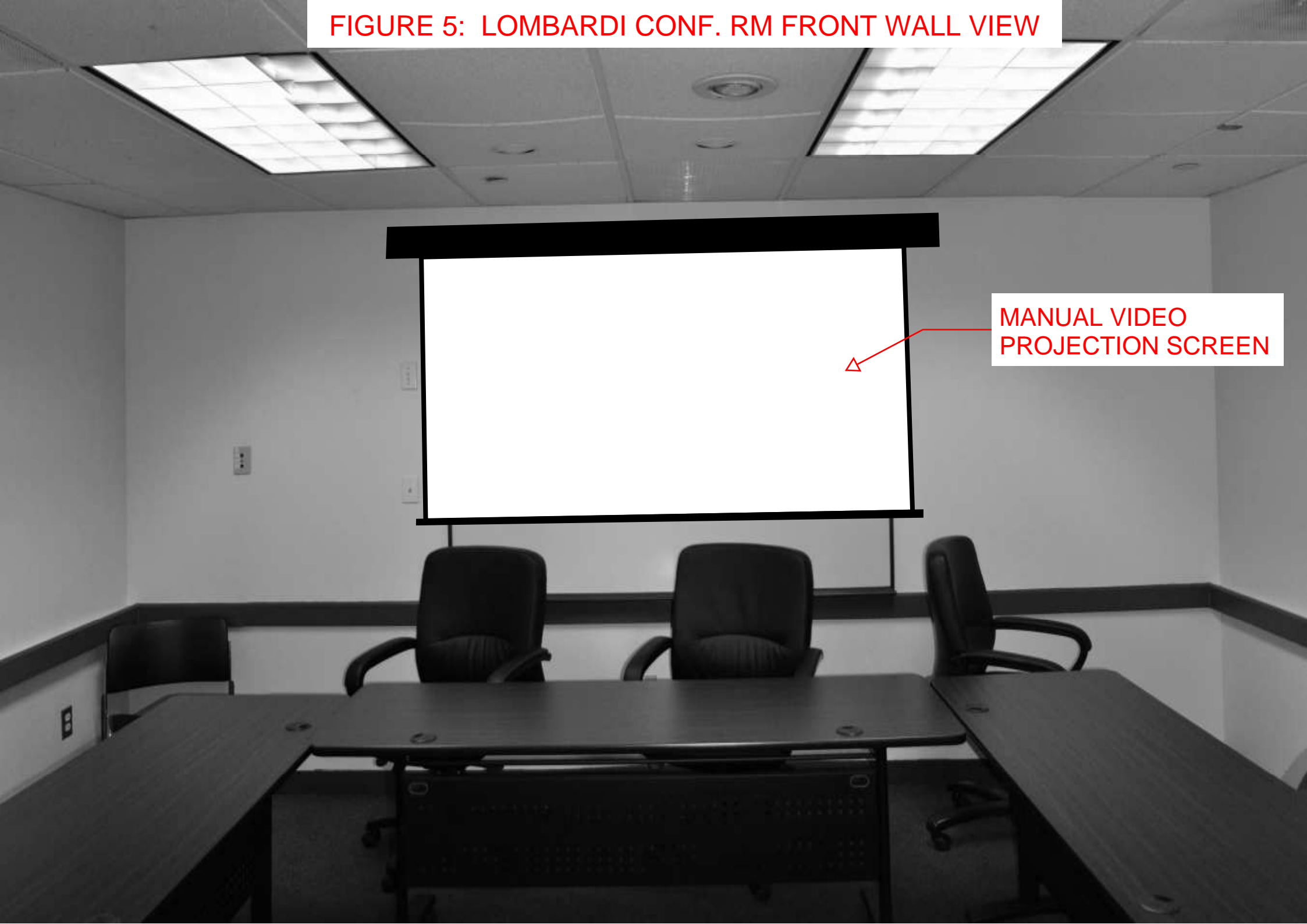
FIGURE 4: SOPHIE J. ANASTOS FRONT WALL VIEW



WALL-MOUNTED 70 "
LCD DISPLAY PANEL
(ON CUSTOM MOUNT)

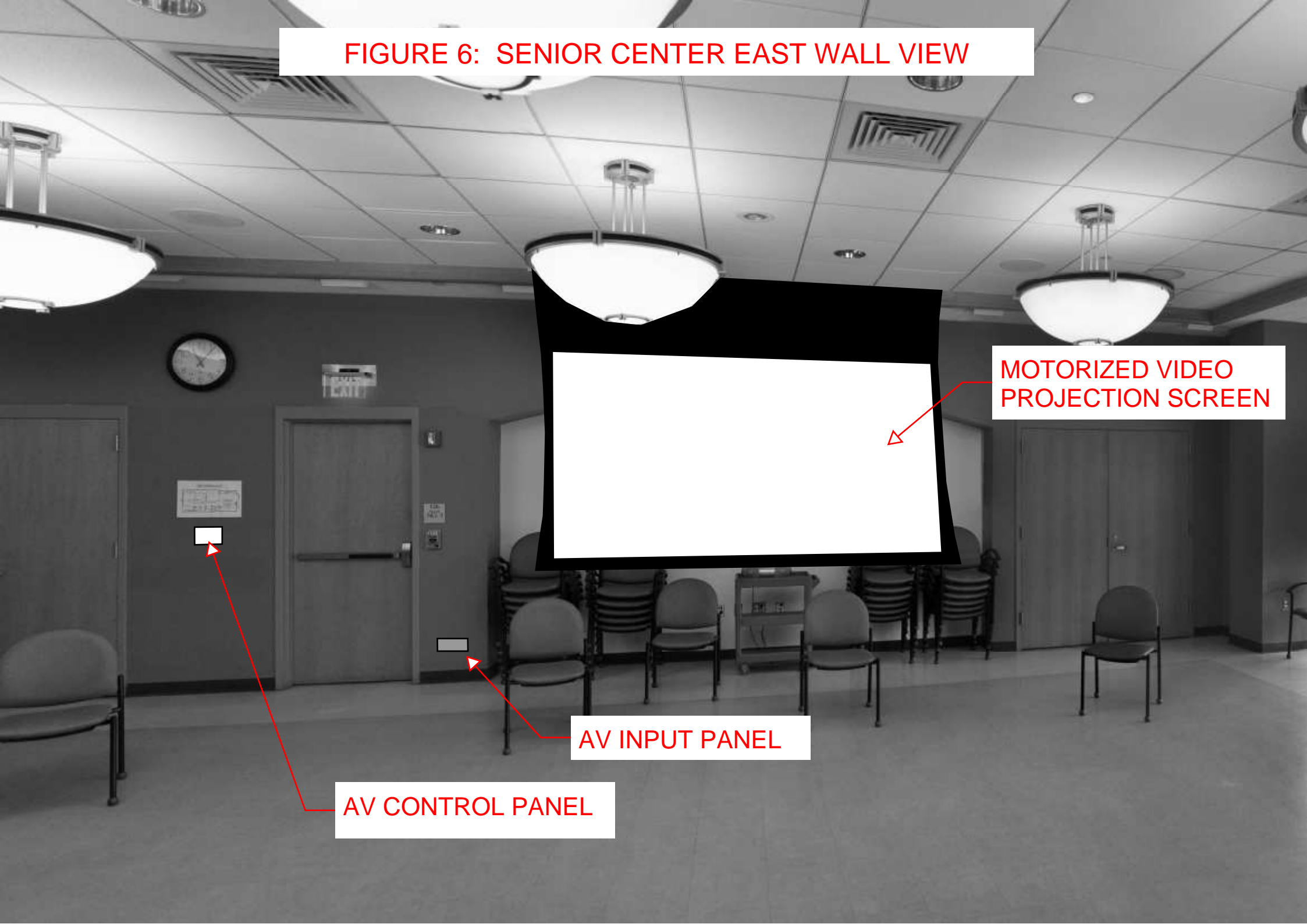
POSITION OF LCD
DISPLAY WHEN NOT
IN USE

FIGURE 5: LOMBARDI CONF. RM FRONT WALL VIEW



MANUAL VIDEO
PROJECTION SCREEN

FIGURE 6: SENIOR CENTER EAST WALL VIEW



MOTORIZED VIDEO
PROJECTION SCREEN

AV INPUT PANEL

AV CONTROL PANEL

FIGURE 7: WATER WORKS MEETING AREA



**SURFACE-MOUNTED
LOUDSPEAKER**



Product Literature – Table of Contents

1.	Video Projector – Sullivan Chamber	32
2.	Projection Screen – Sullivan Chamber	33
3.	Dais Monitor – Sullivan Chamber	38
4.	Motorized Dais Monitor – Sullivan Chamber	40
5.	LCD Display – City Hall	43
6.	Document Camera – Sullivan Chamber	45
7.	Wireless Presentation Device – Sullivan Chamber	53
8.	Cable TV Tuner – Sullivan Chamber	55
9.	Pan/Tilt Video Camera – Sullivan Chamber	57
10.	Secondary Video Camera – Sullivan Chamber	60
11.	Camera Monitors – Sullivan Chamber	63
12.	Program Monitor – Sullivan Chamber	64
13.	Preview/Waveform Monitor – Sullivan Chamber	65
14.	Pan/Tilt Camera Controller – Sullivan Chamber	66
15.	Video Production Switcher – Sullivan Chamber	68
16.	Video Capture/Streaming – Sullivan Chamber	76
17.	Audio and Video Switching and Transmission System	81
18.	Digital Audio Signal Processor – Sullivan Chamber	85
19.	Loudspeaker – Sullivan Chamber & Waterworks	87
20.	Assistive Listening System	96
21.	AV Control Panel – Sullivan Chamber, City Hall Annex, Senior Ctr.	97
22.	AV Control Panel – Conference Rooms	100
23.	Videoconference Codec – Ackermann Room	104
24.	Audio Conference Unit	106
25.	Video Projector – Senior Ctr., Lombardi Bldg, City Hall Annex, Portable System	109
26.	Projection Screen – Senior Center	115
27.	Portable Powered Loudspeaker	116
28.	Portable Projection Screen	118
29.	Portable Wireless Microphone	119

VIDEO PROJECTOR - SULLIVAN CHAMBER

Panasonic
ideas for life

PT-DZ8700 Series

3-Chip DLP™ Projectors

PT-DZ8700U
PT-DS8500U
PT-DW8300U



A Bright 10,600 lm* in a Compact Body

* The PT-DW8300U has 9,600 lm of brightness.



Model CB ElectriScreen

Stewart's Large Venue ElectriScreen models are custom engineered for applications that require large-scale video projection displays



- Production sizes up to 25 feet by 39 feet 6 inches
- 8-inch Diameter "stressed" roller-tube
- Continuous duty outboard motor and brake system
- Available in 120 Volt and 240 Volt motor options

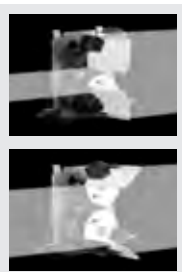
Brightness & Picture Quality

Compact Yet Bright

Panasonic's original dual-lamp system, with its new 355-W lamp, has helped to make the body as compact as Panasonic's original PT-D7700U Series, while providing a full 10,600 lm^{*1} of brightness with 120-VAC operation.

New Dynamic Iris for a High 10,000:1^{*2} Contrast Ratio

Panasonic's new Dynamic Iris uses a scene-linking aperture mechanism to achieve a remarkable 10,000:1^{*2} contrast without lowering its high brightness. This helps to reproduce deeper, richer blacks, and provides images with more detailed textures.



Detail Clarity Processor 3 Brings Depth and Clarity to Details

The frequency of the video signal is analyzed for each scene, and distribution data is extracted for the ultrahigh, high, medium and low range frequencies. This unique Panasonic image correction circuit optimally enhances each area of the screen. High-precision detection is applied from 2-dimensional horizontal/vertical data to produce more natural, lifelike images with high definition.



Without Detail Clarity Processor 3

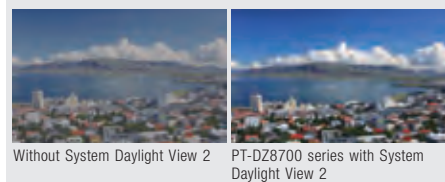


PT-DZ8700U series with Detail Clarity Processor 3

System Daylight View 2 for Enhanced Color Perception

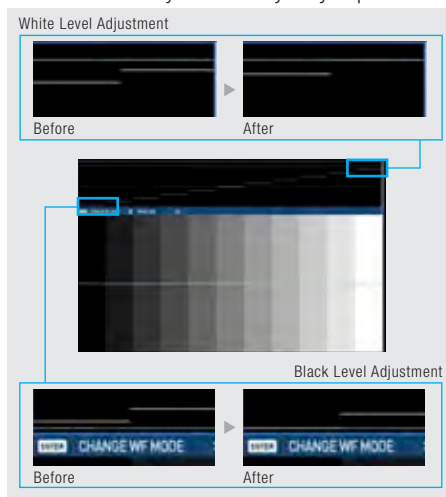
This original Panasonic technology optimizes image quality to improve color perception of the projected image in bright rooms. Gamma curves and sharpness, in addition to conventional color correction, are adjusted to bring a sense of sharpness to the entire screen and reproduce stunning images with lifelike depth. This results in highly comfortable viewing even in bright lighting, and allows viewers

to concentrate easily on the images.



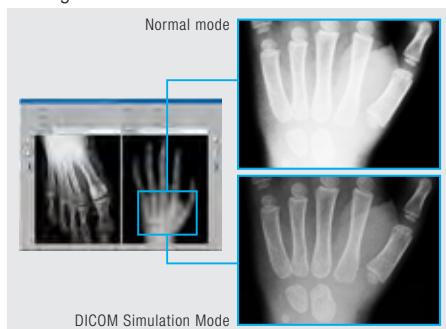
Waveform Monitor Function (PT-DZ8700U)

When the output level of the source device fluctuates due to the performance of the device or its cable connections, the original black and white levels of the image content cannot be reproduced correctly. With the PT-DZ8700U you can view the waveforms on the screen and adjust the settings either automatically or manually as you prefer.



DICOM Simulation Mode^{*3}

This imaging mode is similar to DICOM part 14, which is a medical imaging standard. It reproduces X-ray images with remarkable clarity. It also allows information to be shared by many viewers on a large screen, such as during conferences or training courses.



Full-HD Ready WUXGA Resolution (PT-DZ8700U)

In response to the increasing popularity of wide-screen image viewing, including Blu-ray content, the PT-DZ8700U features native WUXGA resolution for full-HD viewing. This brings you lifelike projection of intricate, highly detailed images.

Advanced Technologies for Excellent Image Quality

- 3D color management system
- Full 10-bit image processing
- Progressive cinema scan

- (3:2 pulldown)
- Dynamic sharpness control
- Digital noise reduction
- IP conversion
- AI scene control
- 2:2 pulldown mode
- 3D Y/C separation
- sRGB compatibility

Reliability & Stability

Panasonic's Original Dual Lamp System

This system eliminates the interruption if a lamp should fail (in dual-lamp operation mode). The Lamp Relay mode also operates the lamps alternately to enable 24/7 projection.

Lamp	Brightness (lumens)		Lamp replacement cycle (hours) ^{*4}
	PT-DZ8700U PT-DS8500U	PT-DW8300U	
Two lamps (high)	10,600	9,600	3,000
Two lamps (low)	8,480	7,680	4,000
One lamp (high)	5,300	4,800	6,000
One lamp (low)	4,240	3,840	8,000

Auto Cleaning Filter Reduces Maintenance Hassles



Panasonic's proprietary Auto Cleaning Filter (ACF) automatically exposes a clean filter surface when it senses that the filter is clogged. The ACF also brushes away dust that adheres to the filter, which helps prevent clogging that can impair operation or cause malfunction. This helps maintain the superior dust-collecting performance of the Micro Cut Filter, which is a highly efficient electrostatic filter. As a result, the filter does not need to be replaced for up to 10,000 hours^{*5} or more, greatly reducing the hassle of maintenance.



Optional Smoke Cut Filter ET-SFD310

The projector can be equipped with an optional, extra-strong air filter to prevent the entry of smoke, such as those used for special effects at events and stage performances.



Quiet 37-dB^{*6} Operation

An original cooling system enhances the compact body and enables the projector to operate at a silent 37 dB.

NOTES

- *1** The PT-DW8300U has 9,600 lm of brightness.
- *2** In Dynamic Iris mode 3.
- *3** This product is not a medical instrument. Do not use it for actual medical diagnosis.
- *4** The values above are maximum values when they are used in cycles of being turned on for 2 hours and off for 0.25 hour. When the lamps are turned on and off more frequently, the lamp replacement cycle is shortened. It is recommended that the mechanical shutter be used to turn images off for a short period.
- *5** The usage environment influences the duration of the filter.
- *6** In dual lamp operation, with lamp low mode. Measurement, measuring conditions, and method of notation all comply with ISO 21118 international standards.

Enhanced Installation Flexibility

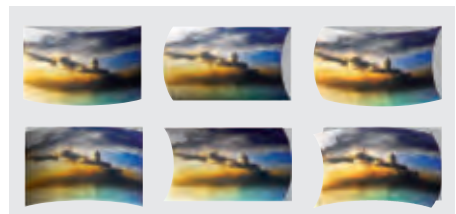
Flexible Installation

The wide adjustment range of the powered horizontal/vertical lens shift function assures virtually distortion-free images and adds convenience and versatility. It lets you easily make adjustments with the remote control. The unit can also be rotated 360° vertically. This means you can install it at any angle you want, to accommodate different installation conditions. The lens-centered design also contributes to easy installation.



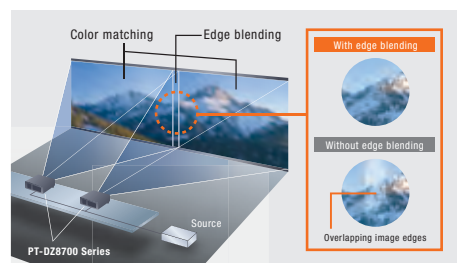
Geometric Adjustment*7 for Specially Shaped Screens

This function adjusts the image for projection onto spherical, cylindrical and other specially shaped screens. You can make the adjustment easily using just the remote control, with no external equipment needed. Used together with the multi-screen support system, Geometric Adjustment expands your application possibilities, letting you create a wide range of image effects for digital signage, concerts, performances and other special events.



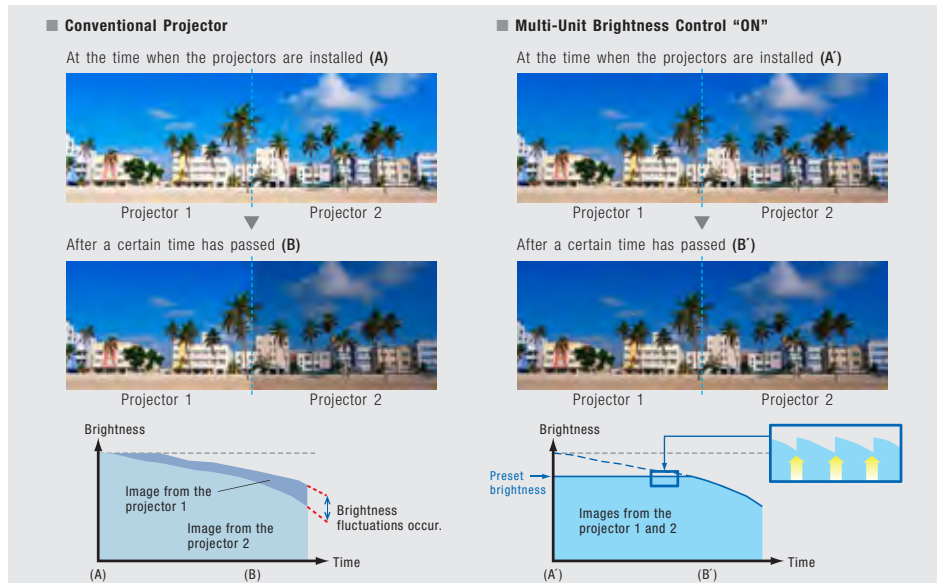
Multi-Screen Support System Seamlessly Connects Multiple Screens

- Edge Blending**
 The edges of adjacent screens can be blended and their luminance controlled.
- Color Matching**
 This function corrects for slight variations in the color reproduction range of individual projectors. The PC software assures easy, accurate control.
- Multi-Screen Processor**
 The PT-DZ8700 series can project large, multi-screen images without any additional equipment. Up to 100 units (10 × 10) can be edge-blended at a time.



Multi-Unit Brightness Control

This function automatically corrects the brightness fluctuations that occur over time in the individual projectors of a multi-screen system. A maximum



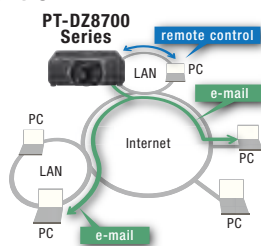
Multi Projector Monitoring & Control Software Ver. 2

Panasonic's original freeware "Multi Projector Monitoring & Control Software Ver. 2" allows the user to control and monitor multiple projectors at the same time over a wired LAN. When a problem occurs, an alarm message is sent to the monitoring/controlling PC.



Web Browser Control

The PT-DZ8700 series can be easily operated remotely over a LAN network, because it is all done using the computer's familiar web browser. Furthermore, the projector sends an e-mail message to notify the operator when an error has occurred, or a lamp needs to be replaced.



PJLink™ Compatibility

The LAN terminals support PJLink™ class 1 connection. Control with the same specifications is also possible when used in a multi-projector system with projectors of another brand.

of eight projectors can be controlled by connecting each other via a hub, and this can be increased to a maximum of 2,048 projectors by using "Multi Projector Monitoring & Control Software Ver. 2".

A Wide Selection of Lenses (optional)

Choose from a wide lineup of lenses for your system, including short-throw, long-throw zoom and fixed-throw lenses for rear projection use. The additional lenses make it easy to adapt your projector to the installation site. The lenses attach and detach with one-touch ease.

Multiple Terminals with HD-SDI Compatibility*8

The PT-DZ8700 series has an array of terminals, including a DVI-D (HDCP compliant), to support a broad range of projection needs. Using the serial terminal (RS-232C), it is possible to connect and operate AMX and Crestron control systems with ease. In addition, the PT-DZ8700U and PT-DS8500U accommodate the HD/SD-SDI input signals that are widely used in broadcasting.

Direct Power Off

The cooling fan continues to operate even when the main power switch is turned off after projection is finished. This also allows the power to be turned off by directly switching off the room's main breaker for systems, such as ceiling mounted systems, where the main power switch cannot be reached.

Scheduling Function

Scheduled operation is possible using the built-in timer function, without having to use a PC and software. For example, when using the projector for digital signage in a store, it can be set to operate with two lamps in the daytime and one lamp at night.

NOTES

*7 Featured on the PT-DZ8700U and PT-DS8500U only. *8 Featured on the PT-DZ8700U and PT-DS8500U only.

Standby Mode: Eco*9

The PT-DZ8700 series has attained a low stand-by power level of 0.2W*10, which is a top-class level for the projector industry. It also helps to slash running costs, and reduces environmental impact.

Other Valuable Features

- Operation in temperatures up to 45°C (113°F)*11
- Picture in picture*12
- Mechanical lens shutter
- 30m long range wireless remote control
- Anti-theft features with chain opening
- ID assignment for up to 64 units
- Built-in test pattern
- Selectable 9-language on-screen menu (English, German, French, Spanish, Italian, Russian, Japanese, Chinese, Korean)

Ecology-Conscious Design

Panasonic works from every angle to minimize environmental impact in the product design, production and delivery processes, and in the performance of the product during its life cycle. The PT-DZ8700 series projector reflects the following ecological considerations.

- No halogenated flame retardants are used in the cabinet.
- Lead-free solder is used to mount components to the printed circuit boards.
- Lamp power switching further reduces power consumption.
- Stand-by power consumption of only 0.2 W*10 has been achieved.
- Auto Power Save activates standby mode when no signal is input.

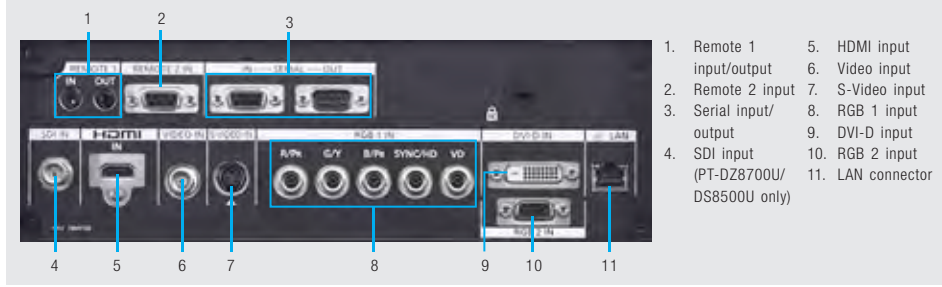


All PT-DZ8700 series projectors are carefully manufactured at the Panasonic factory in Japan, under strict quality control. This is another, very important advantage of a Panasonic projector.

Optional Accessories



Terminals



1. Remote 1
2. Remote 2 input
3. Serial input/output
4. SDI input
5. HDMI input
6. Video input
7. S-Video input
8. RGB 1 input
9. DVI-D input
10. RGB 2 input
11. LAN connector (PT-DZ8700U/DS8500U only)

Projection Distance

PT-DZ8700U (16:10 aspect ratio)

Diagonal image size	Throw distance													
	ET-D75LE6 0.9-1.1:1		ET-D75LE10 1.3-1.7:1		ET-D75LE20 1.7-2.4:1		ET-D75LE30 2.4-4.7:1		ET-D75LE4 4.6-7.4:1		ET-D75LE8 7.3-13.8:1		ET-D75LE5 0.7:1	
	min.	max.	min.	max.	min.	max.	min.	max.	min.	max.	min.	max.	min.	max.
1.78 [70]	1.35 (4.5)	1.62 (5.3)	1.90 (6.3)	2.46 (8.1)	2.46 (8.1)	3.58 (11.9)	3.56 (11.2)	6.94 (22.8)	6.91 (22.7)	11.06 (36.3)	10.78 (36.4)	20.56 (67.5)	0.99 (3.3)	
2.54 [100]	1.96 (6.5)	2.34 (7.7)	2.76 (9.1)	3.56 (11.7)	3.55 (11.7)	5.17 (17.0)	5.13 (17.0)	9.99 (32.8)	9.92 (32.6)	15.85 (51.1)	15.57 (51.1)	29.53 (96.9)	1.45 (4.8)	
3.81 [150]	2.96 (9.8)	3.55 (11.7)	4.18 (13.6)	5.40 (17.8)	5.37 (17.7)	7.81 (25.7)	7.75 (25.5)	15.08 (49.5)	14.93 (49.0)	23.82 (78.2)	23.54 (77.3)	44.47 (146.0)	2.22 (7.3)	
5.08 [200]	3.97 (13.1)	4.75 (15.6)	5.60 (18.4)	7.24 (23.8)	7.19 (23.6)	10.45 (34.3)	10.38 (34.1)	20.17 (66.2)	19.95 (65.5)	31.80 (104.4)	31.52 (103.5)	59.41 (195.0)	2.99 (9.9)	
7.62 [300]	5.99 (19.7)	7.17 (23.6)	8.40 (27.7)	10.91 (35.8)	10.82 (35.6)	15.73 (51.7)	15.62 (51.3)	30.34 (99.6)	29.98 (98.4)	47.75 (156.7)	47.47 (155.8)	89.30 (293.0)	4.53 (14.9)	
10.16 [400]	8.00 (26.3)	9.58 (31.5)	11.28 (37.1)	14.58 (47.9)	14.46 (47.5)	21.01 (69.0)	20.86 (68.5)	40.51 (132.9)	40.01 (131.3)	63.70 (209.0)	63.42 (208.1)	119.19 (391.1)	- (-)	
12.70 [500]	10.01 (32.9)	11.99 (39.4)	14.12 (46.4)	18.25 (59.9)	18.09 (58.4)	26.29 (87.2)	26.11 (86.9)	50.68 (168.3)	50.04 (164.2)	78.65 (261.4)	79.37 (260.5)	149.08 (488.1)	- (-)	
15.24 [600]	12.03 (39.5)	14.40 (47.3)	16.96 (55.7)	21.93 (72.0)	21.73 (71.3)	31.58 (103.6)	31.35 (102.9)	60.85 (199.7)	60.07 (197.1)	95.60 (313.7)	95.32 (312.8)	178.96 (587.2)	- (-)	

unit: meters (feet)

PT-DS8500U (4:3 aspect ratio)

Diagonal image size	Throw distance													
	ET-D75LE6 1.0-1.2:1		ET-D75LE10 1.4-1.8:1		ET-D75LE20 1.8-2.6:1		ET-D75LE30 2.6-5.1:1		ET-D75LE4 5.0-8.0:1		ET-D75LE8 7.9-15.0:1		ET-D75LE5 0.8:1	
	min.	max.	min.	max.	min.	max.	min.	max.	min.	max.	min.	max.	min.	max.
1.78 [70]	1.39 (4.6)	1.66 (5.5)	1.95 (6.3)	2.52 (8.2)	2.52 (8.2)	3.66 (12.1)	3.64 (12.0)	7.10 (23.3)	7.10 (23.3)	11.37 (37.4)	11.09 (36.4)	21.14 (69.4)	1.02 (3.4)	
2.54 [100]	2.01 (6.7)	2.41 (7.9)	2.82 (9.3)	3.64 (12.0)	3.63 (12.0)	5.28 (17.4)	5.24 (17.3)	10.21 (33.6)	10.19 (33.5)	16.29 (53.5)	16.01 (52.6)	30.36 (99.6)	1.50 (5.0)	
3.81 [150]	3.05 (10.0)	3.65 (12.0)	4.27 (14.0)	5.52 (18.2)	5.49 (18.0)	7.98 (26.2)	7.92 (26.0)	15.41 (50.6)	15.35 (50.4)	24.49 (80.4)	24.21 (79.5)	45.72 (150.0)	2.29 (7.5)	
5.08 [200]	4.08 (13.4)	4.89 (16.1)	5.72 (18.9)	7.39 (24.3)	7.34 (24.1)	10.67 (35.1)	10.60 (34.9)	20.60 (67.9)	20.50 (67.5)	32.69 (107.3)	32.40 (106.4)	61.08 (200.4)	3.08 (10.1)	
7.62 [300]	6.15 (20.2)	7.37 (24.2)	8.62 (28.3)	11.14 (36.6)	11.06 (36.3)	16.07 (52.8)	15.96 (52.4)	30.99 (101.7)	30.81 (101.1)	49.08 (161.1)	48.80 (160.2)	91.79 (301.2)	4.66 (15.3)	
10.16 [400]	8.22 (27.0)	9.85 (32.4)	11.52 (37.9)	14.80 (48.9)	14.77 (48.8)	21.46 (70.5)	21.31 (70.0)	41.38 (135.8)	41.12 (135.0)	65.47 (214.9)	65.19 (213.9)	122.51 (402.0)	- (-)	
12.70 [500]	10.29 (33.9)	12.33 (40.5)	14.42 (47.4)	18.65 (61.2)	18.48 (61.0)	26.86 (88.2)	26.67 (87.9)	51.77 (168.9)	51.43 (168.3)	81.87 (271.1)	81.59 (270.7)	155.23 (509.2)	- (-)	
15.24 [600]	12.36 (40.6)	14.81 (48.6)	17.33 (56.9)	22.40 (73.5)	22.20 (72.9)	32.25 (105.9)	32.03 (105.1)	62.15 (204.0)	61.74 (202.6)	98.26 (322.4)	97.98 (321.5)	183.95 (603.6)	- (-)	

unit: meters (feet)

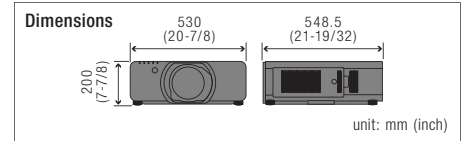
PT-DW8300U (16:9 aspect ratio)

Diagonal image size	Throw distance													
	ET-D75LE6 1.0-1.2:1		ET-D75LE10 1.4-1.9:1		ET-D75LE20 1.8-2.7:1		ET-D75LE30 2.7-5.2:1		ET-D75LE4 5.2-8.2:1		ET-D75LE8 8.2-15.4:1		ET-D75LE5 0.8:1	
	min.	max.	min.	max.	min.	max.	min.	max.	min.	max.	min.	max.	min.	max.
1.78 [70]	1.56 (5.2)	1.87 (6.2)	2.18 (7.2)	2.82 (9.3)	2.82 (9.3)	4.10 (13.5)	4.07 (13.4)	7.94 (26.1)	7.94 (26.1)	12.71 (41.8)	12.43 (40.8)	23.65 (77.6)	1.15 (3.8)	
2.54 [100]	2.25 (7.4)	2.70 (8.9)	3.16 (10.4)	4.08 (13.4)	4.06 (13.4)	5.91 (19.4)	5.87 (19.3)	11.42 (37.5)	11.40 (37.4)	18.21 (59.8)	17.92 (58.9)	33.94 (111.4)	1.68 (5.6)	
3.81 [150]	3.41 (11.2)	4.08 (13.4)	4.78 (15.7)	6.18 (20.3)	6.14 (20.2)	8.92 (29.3)	8.86 (29.1)	17.23 (56.6)	17.15 (56.3)	27.36 (90.8)	27.08 (88.9)	51.10 (167.7)	2.56 (8.5)	
5.08 [200]	4.56 (15.2)	5.47 (18.2)	6.40 (21.0)	8.27 (27.2)	8.21 (27.0)	11.93 (39.2)	11.85 (39.0)	23.03 (75.6)	22.91 (75.2)	36.51 (120.5)	36.23 (120.4)	68.25 (224.0)	3.45 (11.4)	
7.62 [300]	6.87 (22.6)	8.24 (27.1)	9.64 (31.7)	12.46 (40.9)	12.36 (40.6)	17.96 (59.0)	17.83 (58.6)	34.63 (113.7)	34.42 (113.0)	54.82 (179.9)	54.54 (179.0)	102.55 (338.5)	5.21 (17.1)	
10.16 [400]	9.18 (30.2)	11.01 (36.2)	12.88 (42.3)	16.65 (54.7)	16.50 (54.2)	23.98 (78.2)	23.81 (78.2)	46.23 (151.7)	45.93 (150.8)	73.13 (240.0)	72.85 (239.1)	136.85 (449.0)	- (-)	
12.70 [500]	11.49 (37.8)	13.78 (45.2)	16.12 (52.9)	20.84 (69.4)	20.65 (67.8)	30.01 (98.5)	29.80 (97.8)	57.83 (188.9)	57.45 (188.3)	91.43 (300.2)	91.16 (300.1)	171.16 (562.8)	- (-)	
15.24 [600]	13.80 (45.3)	16.55 (54.3)	19.36 (63.6)	25.02 (82.1)	24.80 (81.4)	36.03 (118.3)	35.78 (117.4)	69.43 (227.8)	68.96 (226.3)	109.74 (360.7)	109.47 (359.2)	205.46 (674.1)	- (-)	

unit: meters (feet)

NOTES

*9 When the standby mode is set to ECO, network functions such as power on over the LAN network will not operate, and the serial output terminal cannot be used. Also, only certain commands can be received for external control using the serial terminal. *10 With the standby mode set to ECO. *11 The operating temperature is 0°C to 40°C (32°F to 104°F) when the fan control is set to High Altitude mode (for over 1,400 m (4,593 ft) to 2,700 m (8,858 ft) above sea level). *12 This function cannot be used with some input signals and selected inputs.



Specifications

Model	PT-DZ8700U	PT-DS8500U	PT-DW8300U
Power supply	120 V AC, 9.5 A, 60 Hz	120 V AC, 9.0 A, 60 Hz	
Power consumption	970 W (1,000 VA) (0.2 W with standby mode set to ECO*2 6 W with standby mode set to NORMAL. Both with fan stopped.)	920 W (970 VA) (0.2 W with standby mode set to ECO*2 6 W with standby mode set to NORMAL. Both with fan stopped.)	
DLP™ chip	Panel size Display method Pixels	Panel size Display method Pixels	Panel size Display method Pixels
Lens	Optional powered zoom/focus lenses		
Lamp	355 W UHM lamp × 2 (dual lamp system)		
Screen size (diagonal)	1.78–15.24 m (70–600 in)*3 (16:10 aspect ratio)	1.78–15.24 m (70–600 in)*3 (4:3 aspect ratio)	1.78–15.24 m (70–600 in)*3 (16:9 aspect ratio)
Brightness*1	10,600 lm (dual lamp, high mode)		9,600 lm (dual lamp, high mode)
Center-to-corner uniformity*1	90 %		
Contrast*1	10,000:1 (full on/full off, in dynamic iris 3 mode)		
Resolution	1,920 × 1,200 pixels	1,400 × 1,050 pixels (Input signals that exceed this resolution will be converted to 1,400 × 1,050 pixels.)	1,366 × 768 pixels (Input signals that exceed this resolution will be converted to 1,366 × 768 pixels.)
Scanning frequency	SDI SD-SDI signal: 480i, 576i (SMPTE 259M compliant) Single-link HD-SDI signal: 720/50p, 720/60p, 1035/60i, 1080/50i, 1080/60i, 1080/25p, 1080/24p, 1080/24sF, 1080/30p (SMPTE 292M compliant)		–
HDMI/DVI-D/RGB YPbPr (YCbCr)	fH 15 kHz–100 kHz, fV 24 Hz–120 Hz, dot clock 162 MHz or lower fH 15.75 kHz, fV 60 Hz [525i (480i)] fH 45.00 kHz, fV 60 Hz [750 (720)/60p] fH 28.13 kHz, fV 50 Hz [1125 (1080)/50i] fH 33.75 kHz, fV 30 Hz [1080/30p] fH 15.63 kHz, fV 50 Hz [625i (576i)] fH 37.50 kHz, fV 50 Hz [750 (720)/50p] fH 28.13 kHz, fV 25 Hz [1080/25p] fH 67.50 kHz, fV 60 Hz [1080/60p] fH 31.50 kHz, fV 60 Hz [525p (480p)] fH 33.75 kHz, fV 60 Hz [1035/60i] fH 27.00 kHz, fV 24 Hz [1080/24p] fH 56.25 kHz, fV 50 Hz [1080/50p] fH 31.25 kHz, fV 50 Hz [625p (576p)] fH 33.75 kHz, fV 60 Hz [1125 (1080)/60i] fH 27.00 kHz, fV 48 Hz [1080/24sF]		
Video/S-Video	fH 15.75/15.63 kHz, fV 50/60 Hz [NTSC, NTSC4.43, PAL, PAL60, PAL-N, PAL-M, SECAM]		
Optical axis shift	Vertical ±55% from center of screen (powered) (±44% with the ET-D75LE6)	±50% from center of screen (powered) (±40% with the ET-D75LE6)	±70% from center of screen (powered) (±60% with the ET-D75LE6)
	Horizontal ±20% from center of screen (powered) (±15% with the ET-D75LE6)	±30% from center of screen (powered) (±20% with the ET-D75LE6)	±30% from center of screen (powered) (±20% with the ET-D75LE6)
Keystone correction range	Vertical: ±40° (±22° with the ET-D75LE5, ±28° with the ET-D75LE6)*4, horizontal: ±15° (±10° with the ET-D75LE6)*4		
Installation	Ceiling/floor, front/rear		
Terminals	SDI IN BNC × 1 SD-SDI signal (YCbCr 4:2:2 10-bit): SMPTE 259M compliant: 480i, 576i Single-link HD-SDI signal (YPbPr 4:2:2 10-bit): SMPTE 292M compliant: 720/50p, 720/60p, 1035/60i, 1080/50i, 1080/60i, 1080/25p, 1080/24p, 1080/24sF, 1080/30p		–
	HDMI IN HDMI 19-pin × 1 (Deep Color, compatible with HDCP, 480p, 576p, 720/60p, 720/50p, 1080/60i, 1080/50i, 1080/24p, 1080/24sF, 1080/25p, 1080/30p, 1080/60p, 1080/50p (non-interlaced signals only), VGA (640 × 480)–WUXGA*5 (1,920 × 1,200), dot clock: 25–162 MHz		
	DVI-D IN DVI-D 24-pin × 1 (DVI 1.0 compliant, compatible with HDCP, compatible with single link only, 480p, 576p, 720/60p, 720/50p, 1080/60i, 1080/50i, 1080/24p, 1080/24sF, 1080/25p, 1080/30p, 1080/60p, 1080/50p, VGA (640 × 480)–WUXGA*5 (1,920 × 1,200), compatible with non-interlaced signals only, dot clock: 25–162 MHz		
	RGB 1 IN RGB 2 IN VIDEO IN S-VIDEO IN SERIAL IN SERIAL OUT REMOTE 1 IN REMOTE 1 OUT REMOTE 2 IN LAN	BNC × 5 (RGB/YPbPr/YCbCr × 1) D-sub HD 15-pin (female) × 1 (RGB/YPbPr/YCbCr × 1) BNC × 1 (composite video) Mini DIN 4-pin × 1 (S-Video) D-sub 9-pin (female) × 1 (for external control, RS-232C compliant) D-sub 9-pin (male) × 1 (for link control, RS-232C compliant) M3 jack × 1 (for wired remote control) M3 jack × 1 (for link control) D-sub 9-pin (female) × 1 (for external control, contact control) RJ-45 × 1 (for network connection, 10Base-T/100Base-TX, compliant with PLink™)	
Cabinet materials	Molded plastic		
Dimensions (W × H × D)	530 × 200 × 548.5 mm (20-7/8 × 7-7/8 × 21-19/32 in) (with legs at shortest position, optional lens not included)		
Weight	Approximately 24 kg (52.9 lb) (optional lens not included)		
Operating environment	Operating temperature: 0°C–45°C (32°F–113°F)*6, operating humidity: 10%–80% (no condensation)		
Supplied accessories	Power cord with security lock, wireless/wired remote control unit, batteries for remote control (AA type × 2), safety wire rope		

*1 Measurement, measuring conditions, and method of notation all comply with ISO 21118 international standards. *2 With the standby mode set to ECO. When the standby mode is set to ECO, network functions such as power on over the LAN network will not operate, and the serial output terminal cannot be used. Also, only certain commands can be received for external control using the serial terminal. *3 1.78–7.62 m (70–300 inches) with the ET-D75LE5. *4 When using only the KEYSTONE correction. When using both the KEYSTONE and ARC corrections of the Geometric Adjustment function: vertical ±5°, horizontal ±10° and horizontal ±15° with the ET-D75LE4/D75LE8. *5 WUXGA resolution is supported only when the signals are compliant with VESA CVT-RB (Coordinated Video Timing-Reduced Blanking). *6 The operating temperature range is 0°C (32°F) to 40°C (104°F) when used in High-Altitude mode (1,400 m (4,593 ft) to 2,700 m (8,858 ft)).

NOTES ON USE

- Do not install the projector in locations that are subject to excessive water, humidity, steam, or oily smoke. Doing so may result in fire, malfunction, or electric shock.
- The projector uses a high-voltage mercury lamp that contains high internal pressure. This lamp may break, emitting a large sound, or fail to illuminate, due to impact or extended use.
- The projector uses of high-wattage lamp that becomes very hot during operation. Please observe the following precautions.
 - Never place objects on top of the projector while it is operation.
 - Make sure there is an unobstructed space of 500 mm (19-11/16 in) or more around the projector's exhaust openings.
 - Do not stack projector units directly on top of one another for the purpose of multiple (stacked) projection.
 - When stacking projector units, be sure to provide the amount of space indicated between them. These space requirements also apply to installation where only one projector unit is operating at one time and the other unit is used as a backup.
 - If the projector is placed in a box or enclosure, temperature of the air surrounding the projector must be between 0°C (32°F) and 35°C (95°F). Also make sure the projector's intake and exhaust openings are not blocked. Take particular care to ensure that hot air from the exhaust openings is not sucked into the intake.
- If the projector is to be operated continuously 24 hours a day, use the multi-lamp optical system's alternating lamp operation (lamp changer) function. The projector can be operated continuously 24 hours a day in four-lamp operation mode, but it will automatically operate with three lamps for 8 hours of the 24 hours.
- The lamp replacement cycle duration becomes shorter if the projector is operated repeatedly for short periods.
 - The length of time that it takes for the lamp to break or fail to illuminate varies greatly depending on individual lamp characteristics and usage conditions.
 - The brightness of the lamp will gradually decrease with use.
- Because the ET-D75LE5 is a fixed short-throw lens, the lens shift function cannot be used with it.
- Due to natural characteristics of lamps, screen brightness may vary (flicker). This is not an indication of faulty lamp performance.

Panasonic®

For more information about Panasonic projectors

➡ <http://panasonic.net/avc/projector>



Factories of Systems Business Group have received ISO14001:2004 – the Environmental Management System certification. (Except for 3rd party's peripherals.)

Weights and dimensions shown are approximate. Specifications are subject to change without notice. This product may be subject to export regulations. All other trademarks are the property of their respective trademark owners. Projection Image Audio/Visual Program Medallion logo are trademarks or registered trademarks of Texas Instruments. The PLink trademark is an application trademark in Japan, the United States, and other countries and regions or registered trademarks. © 2010 Panasonic Corporation All rights reserved.

All information included here is valid as of September 2010. Page 37

PT-DZ8700U1 Printed in Japan.

DAIS MONITOR - SULLIVAN CHAMBER



[Products](#) | [Solutions](#) | [Support](#) | [Where to buy](#) | [Acer Store](#)



S230HL Abd

ET.VS0HP.A03

\$ 169.99 [Buy now](#)

[Home page](#) > [Products](#) > [Monitors](#) > [Everyday](#) > [S230HL Abd](#)

S230HL Abd

Share On:

[All Models](#)

[OVERVIEW](#)

[FEATURES](#)

[DATASHEET](#)

[REVIEWS](#)

[COMMENTS](#)

[RELATED](#)

23" widescreen LCD display - 1366 x 768 resolution - 16:9 aspect ratio - 100 million:1 contrast ratio - 5ms response time - 60Hz refresh rate - VGA - DVI (HDCP) - adjustable display angle - 3-year limited warranty



Technical Information

Number of Screens	1
Screen Size	23"
Response Time	5ms
Aspect Ratio	16:9
Horizontal Viewing Angle	170°
Vertical Viewing Angle	160°
Adjustable Display Angle	Yes
HDCP Supported	Yes
Features	Antiglare
Video	
Maximum Resolution	1920 x 1080
Standard Refresh Rate	60Hz
Color Supported	16.7 million
Contrast Ratio	100,000,000:1
Brightness	250 cd/m ²
Audio	

Speakers	No
Interfaces/Ports	
DVI	Yes
VGA	Yes
Power Description	
Operating Power Consumption	<26Watts
Off-Mode Power Consumption	<1 Watts
Physical Characteristics	
Color	Black
Height with Stand	15.1"
Width with Stand	21.58"
Depth with Stand	6.6"
Weight (Approximate)	5.28"
Miscellaneous	
Green Compliance Certificate/Authority	Energy Star®, UL, cUL, FCC Class B, NOM, CE, TUV/GS, VCCI, RoHS, MPRII
Warranty	
Warranty	Limited Warranty agreement applies.

NEED HELP?

[Get support](#)

[Driver downloads](#)

[Acer Community](#)

REGISTER A
PRODUCT

¹ Specifications vary depending on model.

Sale subject to Limited Warranty and Terms & Conditions agreement. All offers subject to change without notice or obligation and may not be available at all retail locations. Prices listed are manufacturer suggested retail prices and may vary by retail location. Applicable taxes extra. Not responsible for pricing or other typographical errors.

Country:  [United States](#)

LATEST POST

Allie's Acer Aspire V5 Touchscreen has the performance to handle multiple tasks at the same time. Explore more: ...

FOLLOW US:

[FACEBOOK](#)

[YOUTUBE](#)

Professional 17.1" widescreen retractable data monitor
with 20 degrees of inclination, to be integrated into meeting and conference room tables

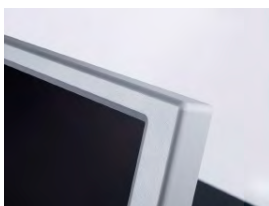
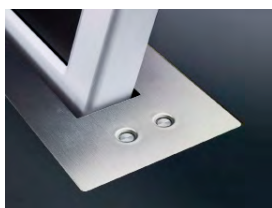
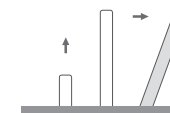
Ref. AH17D216A

GENERAL SPECIFICATIONS

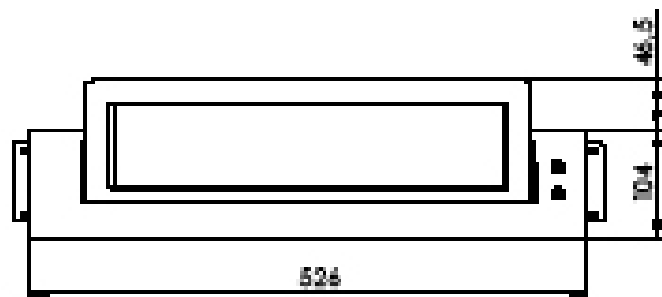
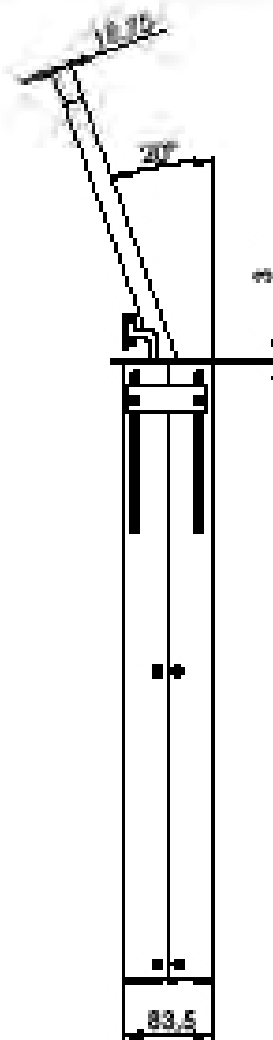
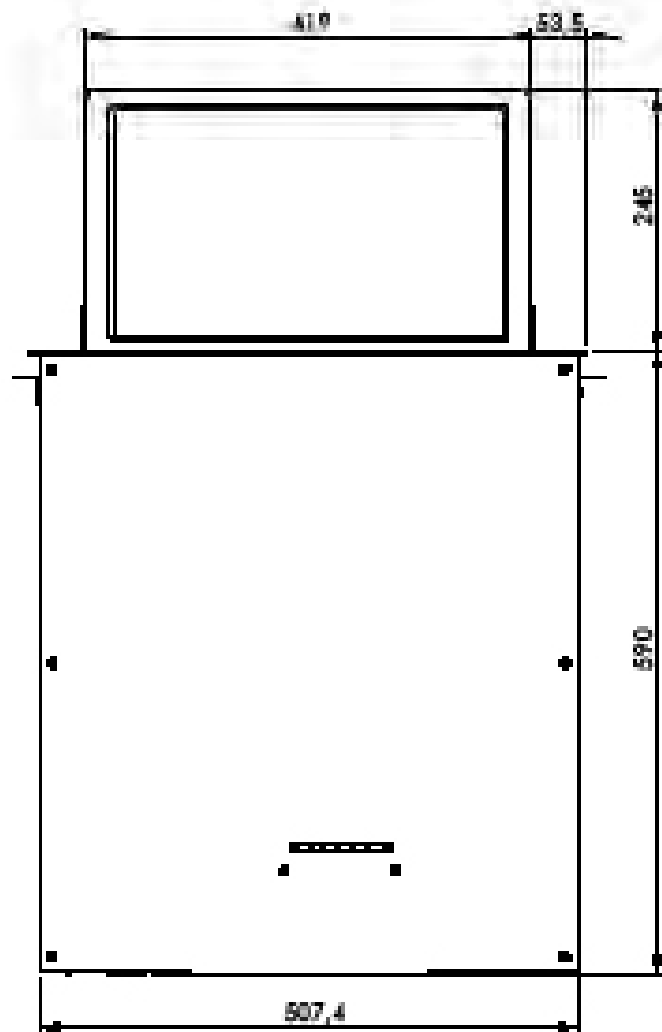
LCD type	17.1" TFT Active Matrix, widescreen format
Cabinet & cover plate	Solid mechanized aluminium housing in anodised finishing. Upper cover plate in brushed stainless steel. Electrical powered lift system with variable speed, 20 degrees of inclination
Controls	Digital
DISPLAY	
Brightness	250cd/m ²
Contrast ratio	800:1
Resolution (dots)	1440 (h) x 900 (v)
Pixel	0.255 (h) x 0.255 (v) mm
Viewing angle	75°/85° (u/d) / 80°/80° (l/r)
Viewing area	367.2 (h) x 229.5 (v) mm
Lamp life	40,000 hrs
ENGINE	
Control UP/DOWN	Buttons on upper cover plate, GPI, RS422
Electronic control	PWM
OTHER	
Response time	Tr 2 ms, Tf 6 ms
Temperature	Operating +0°C ~ +40°C, Storage -20°C ~ +60°C
Monitor control	RS422 (RJ45 CAT5)

CONNECTIONS

Input signal	RGB SubD 15 (1 input) DVI-D (1 input)
RJ45 CAT5 (with loop)	Addressable RS422 monitor control by AH NET protocol
GPI (SubD9)	Up/down control
ELECTRICAL	
External power supply	100-240 Vac, 47/63Hz, 12Vdc - 6.67A
Power consumption	50W
MECHANICAL	
Screen	419 x 245 x 18.75 mm [16.5"x9.6"x0.74"]
Upper cover plate	526 x 104 x 3.1 mm [20.70"x4.09"x0.12"]
Housing below the table	507.4 x 590 x 83.5 mm [20"x23.2"x3.3"]
Weight	15Kg
OPTIONS	
TS17016	SAW touch screen
VCM	Built in videoconferencing camera
EMM	Electrically retractable microphone
CC	Customised cover plate with speaker, voting system, USB connector
ACCESSORIES	
ERT	Ethernet interface unit
AHN	Arthur Holm NET software



Professional 17.1" widescreen
 reproducible data monitor with 30°
 of inclination, to be integrated into
 meeting and conference room tables.

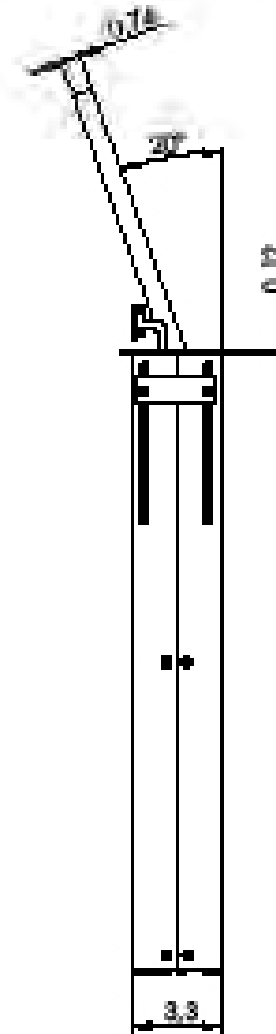
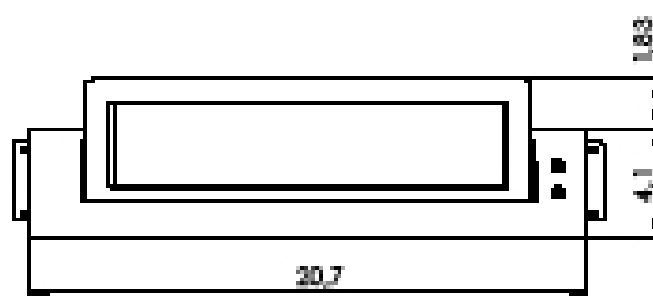
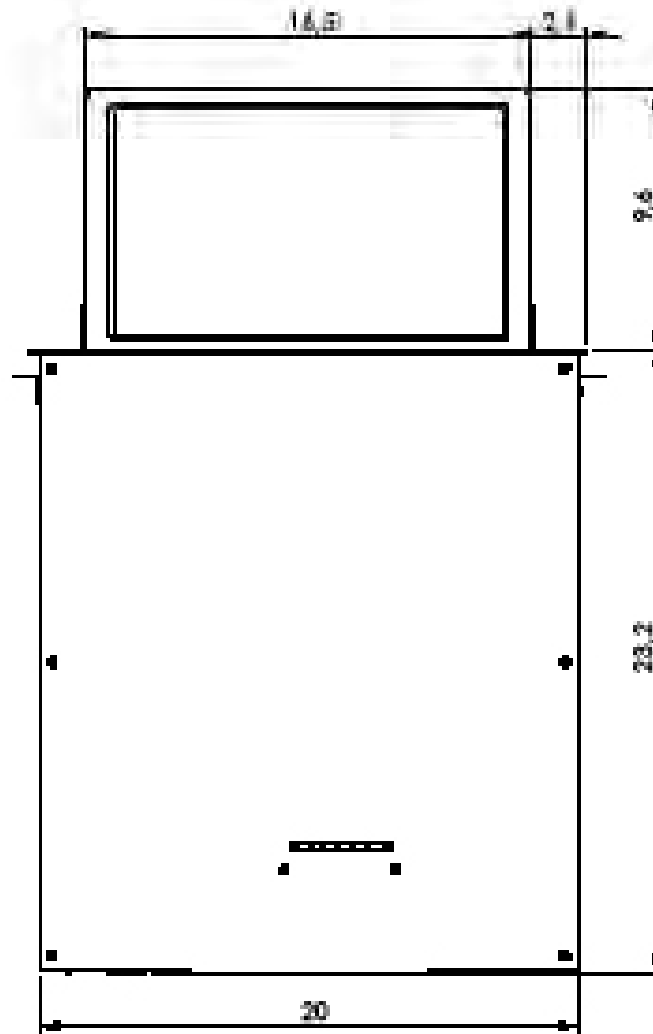


GENERAL DIMENSIONS

Scale 1:1
 Dimensions in millimeters
 Precision 0,1
 Projection

Audiovisual Program

Professional 17.1" widescreen, retractable date monitor with 3D of installation, to be integrated into meeting and conference room tables.



GENERAL DIMENSIONS

Scale 1:1
 Dimension in inches
 Precision 0.1
 Projection

Audiovisual Program

LCD DISPLAY - CITY HALL

Professional, Around-the-Clock Durability That's Also Energy Efficient



Display Your Message – Where You Want, When You Want

With impressive **70" class (69 1/2" diagonal)** and **60" class (60" diagonal)** screens, the PN-E702/E602 let you get your message across with brilliant clarity in nearly any indoor venue. Their sleek and lightweight design – **less than 4" at their thickest points** – allows for nearly limitless installation possibilities, so your message is displayed exactly where it should be.

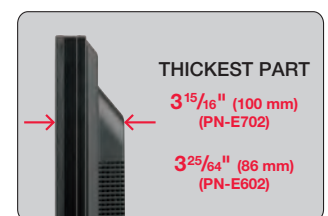


Image Quality That Gets Noticed

We started with **full-array LED backlighting** (PN-E702) and **edge-lit LED backlighting** (PN-E602). Then we incorporated **Sharp's UV2A* technology**, which prevents light leakage and helps ensure the display of truly bright whites, amazingly vivid colors, and extraordinarily deep blacks. Finally, 1920 (h) x1080 (v)-pixel **full HD resolution** helps ensure fine text and intricate graphics are stunningly crisp and clear.

*UV2A technology stands for "Ultraviolet-induced Multi-domain Vertical Alignment," a photo-alignment technology that ensures uniform alignment of liquid crystal molecules in a certain direction.

Durability You Can Put to Work

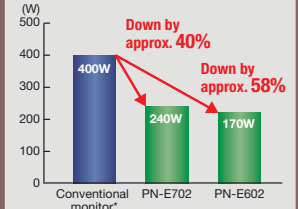
The PN-E702/E602 are **professional-grade** LED digital signage displays built to withstand the rigors of professional use. Operate these workhorses **around-the-clock** and still enjoy stunning image quality and uniform brightness.

Display More, Consume Less

Why use more energy than you have to? The PN-E702/E602 consume **less energy** than traditional CCFL-backlit displays*.

*Compared to Sharp PN-E601

Power Consumption Comparison



Ideal for:

- Conference rooms
- Hotel or office lobbies
- Trade show exhibit halls
- Classrooms and lecture halls
- Indoor shopping plazas and retail spaces

Model Name	PN-E702	PN-E602	
Installation	Landscape and Portrait Mode		
LCD Panel	70" class (69-1/2" diagonal) widescreen, UV-A LCD	60" class (60" diagonal) widescreen, UV-A LCD	
Max. Resolution	1920 x 1080 pixels		
	1,064 million		
	Pixel Pitch (H x V)	0.802 mm x 0.802 mm	0.692 mm x 0.692 mm
	Max. Brightness ¹	450 cd/m ²	
	Contrast ratio	4,000:1	
	Viewing Angle (H/V)	176° / 176° (CR>=10)	
	Active Screen Area (WxH)	60-9/16" x 34-1/16"	52-5/16" x 29-7/16"
	Response Time	6 ms (gray to gray, avg)	
	Backlight	White LED, full array	White LED, edge lit
	Computer Input	Analog RGB (0.7V p-p) (75-ohms), Digital (conforms to DVI 1.0 standards)	
Horizontal/vertical separation (TTL: positive/negative), sync on green, composite sync (TTL: positive/negative)			
VESA DDC2B			
VESA DPMMS, DVI DMPM			
Video Color System	With Optional PN-ZB01 NTSC (3.58 MHz; 4.43 MHz), PAL, PAL60, SECAM		
Input Terminals ²	Standard PC analog: Mini D-sub 15-pin x 1, HDMI x 1 ³ , 3.5 mm diameter-mini stereo jack x 1, RS-232C D-sub 9-pin x 1		
	With Optional PN-ZB01 PC digital: DVI-D 24-pin x 1, PC analog: BNCx1, Video: BNC x 1, S-Video x 1, Component video: BNC (Y, Cb/Pb, Cr/Pr) x 1 ⁴ , Audio RCA pin (L/R) x 2		
Output Terminals	Standard Audio: RCA pin (L/R) x 1, RS-232C D-sub 9-pin x 1		
	With Optional PN-ZB01 PC digital: DVI-24-pin x 1, External speakers: 7W + 7W (6-ohms)		
Input/Output Terminals	With Optional PN-ZB01 LAN port		
Speaker Output	7W + 7W		
Power Supply	100V - 240V AC, 50/60 Hz		
Power Consumption	240 W	170 W	
Environmental	Operating Temperature 0°C to 40°C		
	Operating Humidity 20% to 80% RH		
Dimensions (W x D x H) (approx.) (display only)	63-19/32" x 3-15/16" x 37-9/32"	55-13/32" x 3-3/8" x 32-5/32"	
Weight (not including PN-ZB01) (approx.)	110 lbs.	83.8 lbs.	
Packing Dimensions (W x H x D) (approx.)	72-1/4" x 11-1/4" x 42-5/8"	64-3/16" x 11-1/4" x 37-13/16"	
Carton Weight (approx.)	132 lbs.	105.8 lbs.	
Limited Warranty	3 years on-site, parts and labor		
UPC	074000069244	074000069251	

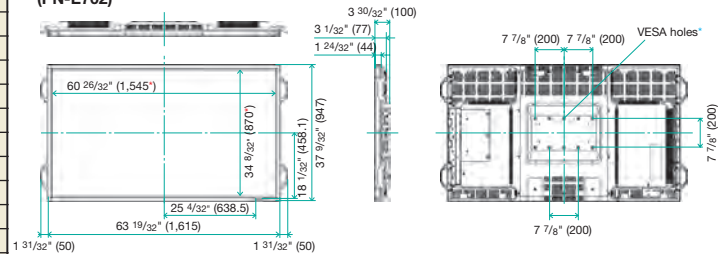
¹ Brightness will depend on input mode and other picture settings. Brightness level will decrease over time. Due to the nature of the equipment, it is not possible to precisely maintain a constant level of brightness. ² Use a commercially available cable for PC and other video connections. ³ For both PC and AV components. ⁴ The analog and component BNC terminals are swappable. Use the menu to select. ⁵ Does not support plug & play.

Sophie & Ackermann Rooms

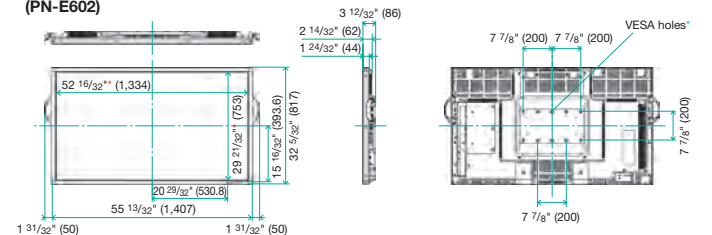
Gallery, Sullivan Chamber

Dimensions

(PN-E702)



(PN-E602)

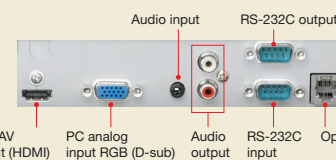


Units: inch (mm)

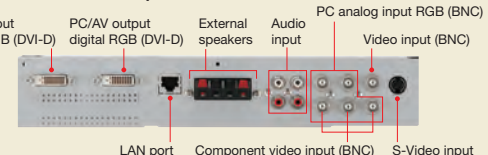
* Screen dimensions * To use the VESA-standard mounting bracket, use M6 screws that are 8 to 10 mm plus the thickness of the bracket.

Input/Output Terminals

(standard)



(option) PN-ZB01 Interface Expansion Board



VZ-9plus³ Desktop Visualizer



Top of the line
performance



Unique Design & Usability

VZ-9plus³ Desktop Visualizer



WolfVision is a globally successful family owned company based in Austria/Europe. As “technology leader“ in the Visualizer market, WolfVision is the company that sets the worldwide standards of product quality, innovation, reliability and ease of use.

The Visualizer VZ-9plus³ is the top of the line model amongst WolfVision’s desktop Visualizers. The advanced version of WolfVision’s popular VZ-8 Visualizer Series.

Additional useful and unique features such as the synchronized lasermarkers and LCD monitor for easier positioning of objects underline its leading position in the Visualizer market. Now in its third generation, the award-winning VZ-9plus³ comes with a completely redesigned housing - new, modern and elegant.



More detailed feature descriptions,
photos and 3D animation at

www.wolfvision.com

Long Lifetime

Our customers appreciate the exceptional mechanical quality and solid design of WolfVision Visualizers. They are built to last for a very long time.



Outstanding Picture Quality

WolfVision Visualizers have always been famous for their outstanding picture quality, which is due to a perfect mix of high end components and remarkable know-how. Perfect picture quality means high resolution throughout the whole picture (including the edges). It means lifelike colors, a high frame rate, fast and precise auto focus, smooth zooming, an overall distortion free picture, even lighting without reflections or hot spots and much more.

WolfVision's high priority on perfect picture quality can be seen throughout the entire Visualizer product line - from entry level models right through to the top of the range units. The picture quality of a Visualizer or camera can only be as good as it's weakest component. Five basic elements are responsible for perfect picture quality:



Main Features

Large Zoom Range

A large optical zoom range is one of the most important features of a Visualizer, because only an optical zoom can pick up objects in full resolution.

WolfVision's 16x optical zoom offers the possibility to pick up objects as large as an open book and as small as a postage stamp in full size to fill the screen. For enlarging even smaller objects the Visualizer also offers 4x digital zoom.

High End Camera

A high definition 1-CCD camera with native image formats of SXGA-, WXGA and 720p HD, gives 820 lines of visible resolution in every part of the picture, including the edges as WolfVision only uses high end camera lenses in its Visualizers.

No Light Adjustments Necessary

The light system is optimized for the working surface, so there is never any need to make any light adjustments.

Synchronized Lasermarkers & Preview Monitor

The unique combination of the "Synchronized Lasermarkers" and the built-in preview monitor makes it easier than ever before to position an object on the working surface.

Turntable

The VZ-9plus³ makes recording outside of the working surface very comfortable as it is mounted on a turntable. In this way a Visualizer can be used just like a camera on a tripod.

Easy To Use / Zoom Wheel

For smooth presentations, it is very important that a Visualizer is extremely easy to use. Less experienced users only need to use the zoom wheel on top of the camera head (or the zoom keys on the remote control) as everything else (focus, iris etc) is adjusted automatically.

290° Tilt Range of Camera

WolfVision's VZ-9 series Visualizers offer the possibility to record almost anywhere in front of or behind the unit.

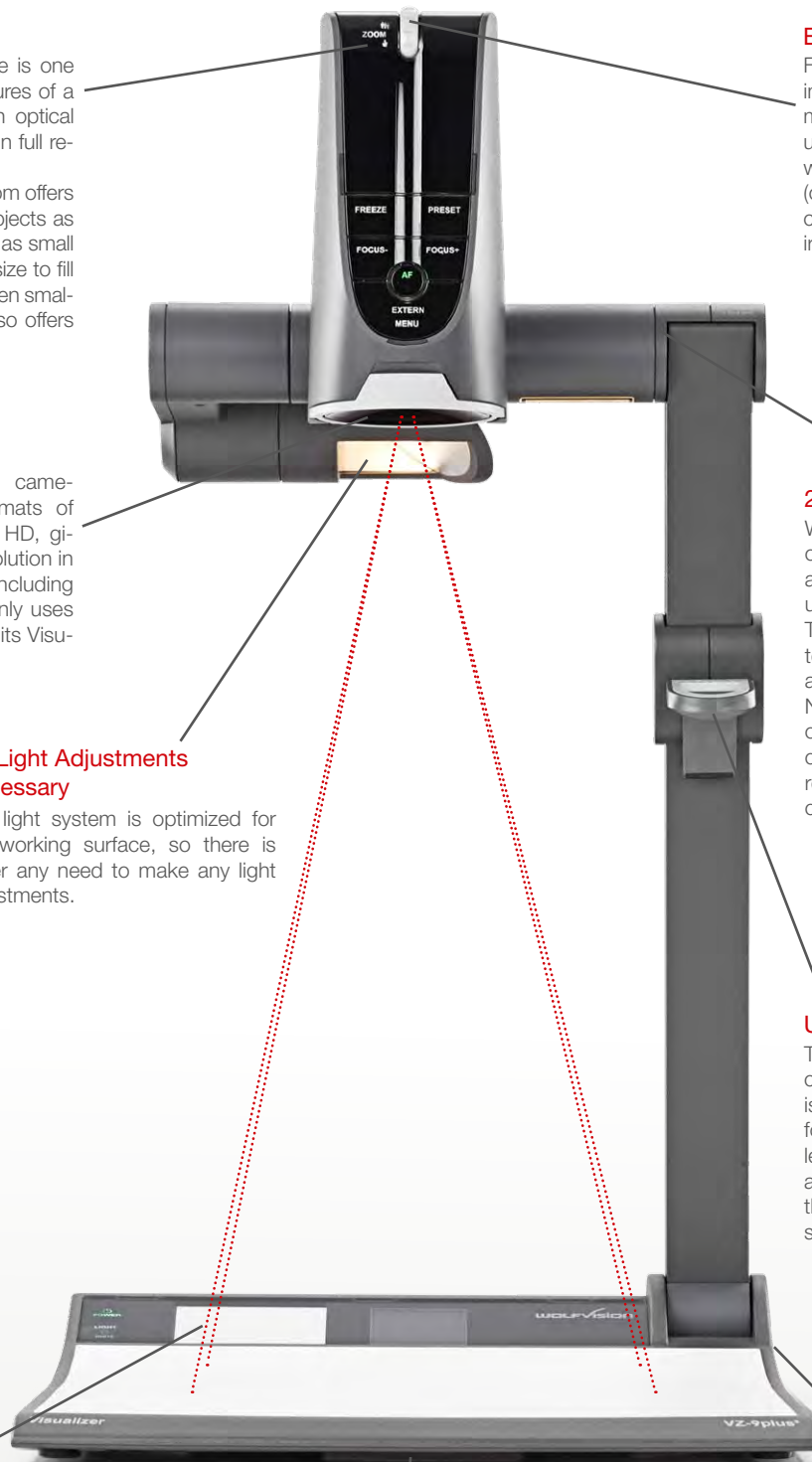
The camera and light can be tilted 180° towards the audience and 110° towards the speaker. Not many Visualizers can record outside of the working surface because tilting the camera and light requires high-grade mechanical components.

Unique Folding System

The most sophisticated mechanical part of the Visualizer VZ-9plus³ is the intelligent arm with its 1-step folding system. With just one simple pull, the arm comes up, camera and light automatically move into the working position and the unit switches on.

Anti-Theft Devices

The Visualizer has two anti-theft devices. There is a thread on the bottom of the working plate for attaching the unit to a table with the supplied table lock bolt. Additionally, T-Lock (Kensington® Lock) devices can also be used.



Feature Highlights



290° tilt range of camera

Synchronized Lasermarkers

Small dots of laser light, projected from the camera head onto the working surface, mark the edges of the pickup area of the camera. This allows for easy positioning of objects on the working surface.

The "lasermarkers" are synchronized with the camera and change accordingly when zooming in and out.

While the "Synchronized Lasermarkers" can clearly be seen on the working surface, they remain invisible in the picture picked up by the camera. The edges of images in 4:3 and 16:10 aspect ratios are marked on the working surface.



Professional PowerPoint Integration

A Visualizer can greatly improve an otherwise stiff PowerPoint presentation by adding the "live factor". It's also the perfect solution to show an unexpected item during a PowerPoint presentation. Simply connect the computer to the external input of the

Visualizer and switch between PowerPoint and Visualizer images using the fade-over effects of the integrated Seamless Switch. This makes the live image of the Visualizer appear to be an integrated part of the PowerPoint presentation.



Outstanding Mechanical Stability and Long Lifetime

Outstanding mechanical quality and durability are basic requirements for all WolfVision products. WolfVision units are solid and not easily damaged. They are built to last for a very long time. If you want to check out the difference

in mechanical stability and reliability between a WolfVision Visualizer and any other document camera on the market, just "touch" the units. You will immediately "feel" the difference.

Advanced Connectivity

USB Device Port/Connectivity Software

The VZ-9plus³ can be connected to a computer using the USB 2.0 or the LAN port. Communication is possible via the WolfVision Connectivity Software or a dedicated WIA, Twain or video capture driver. The supplied Connectivity Software allows for saving still images and videos onto a PC or

Mac, controlling the unit, updating the firmware, adding annotations, instant printing of Visualizer screenshots and even streaming live images over a network. Firmware updates allow new features and technical improvements to be added at no cost!



External Controlling

A wide range of connectivity options ensures that effective external controlling is possible. Serial RS232, USB, LAN and infrared connections can be used to con-

trol the Visualizers from external devices, such as a room control system, a videoconferencing system or a computer.



Internal and External Image Memory/USB Host Port

Nine images can be stored in the internal memory of the unit and recalled instantly by pressing one of the numerical keys on the infrared remote control. The USB host port can be used for connecting

USB sticks and other "passive" USB devices. USB sticks can be used as an extension of the image memory and for uploading and downloading images.



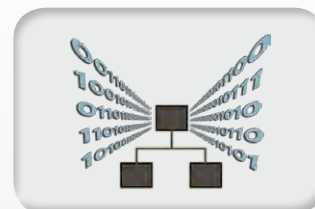
LAN Port / Additional Network Features

The LAN port is a key feature of all high end Visualizers from WolfVision. It makes the Visualizer a part of the internal computer network and it can be used for communication over the Internet, if it is assigned an official (WAN) IP address.

Administrators of a larger number of Visualizers can use the LAN port to control, support and update all of their units from their

local desktop PC. It can be used for controlling, capturing still images, viewing live video streams, firmware updates, adjustments, menu settings and maintenance purposes.

The VZ-9plus³ offers streaming of live images directly from the Visualizer (without a connected PC) in Singlecast (Unicast) and Multicast mode.



More detailed feature descriptions, photos and 3D animation at

www.wolfvision.com

Technical Data

	VZ-9plus ³
Camera	1-CCD 1/3" Progressive Scan
Pictures per second (as picked up by the camera)	30 frames (in all resolutions)
Effective Pixel (=pixels actually used for image information)	1280 x 960 (=1,228,800)
Total pixels of CCD(s)	1,320,000
Pixels processed per second (=effective pixels x frames per second)	36,864,000
Color reproduction / precision	very good colors (sRGB color precision)
Native signal output	SXGA- (1280x960) and WXGA (1280x800) and 720p HD (1280x720)
Converted output signals (4:3 and 5:4)	UXGA (1600x1200), SXGA+ (1400x1050), SXGA (1280x1024), XGA (1024x768), SVGA (800x600)
Converted Widescreen output signals (16:9 and 16:10)	WUXGA (1920x1200), 1080p HD (1920x1080), WSXGA+ (1680x1050), WXGA+ (1440x900), WXGA (1360x768)
Resolution (measured)	820 lines
Resolution in Image Turn mode	1050 lines
Image Rotation	90, 180 and 270 degrees
Iris and White Balance	automatic and manual
Autofocus / Speed	yes (continuously working, high speed)
Manual focus	yes
Shutter	auto, manual, flickerless
Easy positioning of objects with "Synchronized Lasermarkers"	yes (with marks for 4:3 and 16:10 aspect ratio)
Built-in LCD preview monitor	yes (70x45mm / 2.7"x1.8")
Live to Freeze comparison (on two monitors or screens with just one Visualizer)	yes (RGB and DVI output can output different signals. One can output a live image and the other one a "freeze" image)
On screen menu with on screen help	yes
Firmware Updates via	USB, RS232, LAN, USB stick
Zoom / Lens	64 x zoom (16x optical + 4x digital), zoom wheel with multiple speed
Max object height on working surface	230mm (9.6") in tele position 370mm (15") in wide position
Max. pick-up area on working surface	length: 300mm (11.81"), width: 400 mm (15.75")
Max. pick-up area on working surface in Image Turn mode	length: 400mm (15.75"), width: 300 mm (11.81")
Min. pick-up area on working surface (in full resolution, with optical zoom)	25 x 19 mm (0.98" x 0.75")
Min. pick-up area on working surface (with digital zoom)	6 x 4,5 mm (0,23" x 0,16")
Max. pick-up area outside of working surface	unlimited
Depth of focus on small object (42 x 33 mm)	10mm (0.4")
Depth of focus on large object (360 x 270 mm)	260mm (10.2")
Tilt range of camera	290° (110° to speaker + 180° to audience)
Blinding of audience or speaker	none
Light source	long life halogen spot light with aligned facet mirror, vertical rotation 270 degrees, lamp lifetime 5000 hours 50W, 12V
Connectivity Software (USB/LAN), for controlling, image and video capturing and firmware updates	included (for 32- and 64-bit Windows and Macintosh, Twain/WIA compatible, with video capture driver)
Reflection free area on working surface (suitable for transparencies)	whole working surface
Recordings outside of the working surface	yes (to the back and to the front of the unit)
Automatic image flip	yes (for recordings to the front of the unit)
Turntable mounted (for horizontal pan shots outside of the working surface)	yes
Intelligent folding system	articulated arm, 1-step set up
User programmable presets	3 (plus 8 fixed presets through RS232)
Slide pick-up	through integrated slide lightfield
External computer input / Input switch	yes (15-pin D-Sub/VGA plug)
Built-in digital scaler for the computer input	yes (processes the signal from computer input for RGB- and DVI-output)
Seamless switch with fading effects	yes
Image memory	9 pictures in internal memory + unlimited number on USB stick
9 image split-screen ("View function")	yes
Alternative Image display	Text enhancer / negative image / negative-blue image / black and white image
RGB output	one (15-pin D-Sub/VGA-plug)
DVI output	DVI-I (digital and analog)
HDMI output	when using a DVI-HDMI cable
USB standard / port	USB 2.0 Device Port and two USB Host Ports
Ethernet/LAN port, IP-addressable	yes, 10/100 Mbps
Additional network features: multicast and unicast streaming, authentication	yes
RS232 port	9-pin D-Sub
Advanced controlling with professional protocol via RS232, LAN and USB	yes
Weight	6,5kg (14,3lbs)
Infrared remote control	yes (with laserpointer)
Anti-theft device	T-Lock (Kensington® Lock) and table lock bolt
Power (external power pack)	multi range 100-240 V, 80W weight: 0.3kg (0.6lbs)
Carrying case / dust cover	carrying case and dust cover included
Warranty	5 years

All units made in the European Union (Austria)

Design and specifications subject to change!

Your WolfVision dealer:



www.wolfvision.com

Head Office:

WolfVision GmbH
6833 Klaus / Austria
Tel. +43-5523-52250
wolfvision@wolfvision.com

Japan Sales Office
WolfVision Co. Ltd.
Tel. +81-3-33603231
wolfvision.japan@wolfvision.com

USA West Region Sales Office
WolfVision, Inc.
Tel. +1-650-648-0002
sales@wolfvision.us

USA East Region Sales Office
WolfVision, Inc.
Tel. +1-770-931-6802
sales@wolfvision.us

Middle East Sales Office
WolfVision Middle East (Dubai)
Tel. +971-354-2233
middle.east@wolfvision.net

UK Sales Office
WolfVision UK Ltd.
Tel. +44-161-435-6081
wolfvision.uk@wolfvision.com

Canada Sales Office
WolfVision Canada, Inc.
Tel. +1-613-741-9898
wolfvision.canada@wolfvision.com

Asia Sales Office
WolfVision Asia (Singapore)
Tel. +65 6636 1268
info@wolfvisionasia.com

Germany Sales Office
WolfVision GmbH
Tel. 0800-9828-787
wolfvision.deutschland@wolfvision.com

ClickShare

Wireless presentation and collaboration system



ClickShare makes connecting to the meeting room's video system a matter of clicking a button. This one click wonder not only helps the presenter get the presentation on-screen in a second, but it also allows the other people in the meeting to participate more actively. The result is enhanced meeting efficiency and better decision-making.

How it works

A standard ClickShare set-up consists of four USB-powered devices (the 'ClickShare Buttons'), a storage basket to neatly store the Buttons when they're not used (the 'ClickShare Tray') and a Base Unit. The Base Unit has a fixed connection to the meeting room's visualization system, and takes care of all the needed processing. Users who want to get their presentation on the large meeting room screen, simply connect a Button to their PC or MAC. They start the application, click the ClickShare Button and immediately their desktop is wirelessly transferred to the large visualization system. What's more, ClickShare does not interfere with your laptop's resolution, and automatically displays the screen content in the most optimal way.

Confidence and collaboration

ClickShare simply works. This sounds obvious, but considering all the time lost today trying to connect the laptop to the meeting room display, it means a big relief for presenters. The result is enhanced confidence, resulting in better presentations. ClickShare also allows other meeting attendees to participate more actively. When connecting one of the other ClickShare Buttons to their laptop, they can put their content on-screen as well. In total, four participants can be on-screen simultaneously.

ClickShare set

A ClickShare set consists of a Tray, four Buttons and a Base Unit. Additional items are sold separately.

BARCO

Visibly yours

Technical specifications

General specifications	
Operating system	Windows XP Pro, Vista Pro and Windows 7 Pro 32 & 64 bit Mac OS X 10.6, 10.7, 10.8
Video outputs	DisplayPort, Single link DVI-I VGA (via included convertor, highest resolutions only with reduced blanking) In "Dual screen" mode, connection can occur either through DVI and DisplayPort, or through VGA and DisplayPort.
Frame rate	Up to 20fps
Output resolution	XGA, WXGA, SXGA, SXGA+, WXGA+, WSXGA+, UXGA, HD, WUXGA
Input Resolutions	Up to 2048x1536 (QXGA)
Noise Level	Max. 28dBA
Number of sources simultaneous on screen	4
Number of simultaneous connections	25
Audio	Audio compatible from ClickShare Base Unit in software version available at end of Q1 2013
iPad	iPad connectivity possible via optional "ClickShare Link", from ClickShare Base Unit software version available at end of Q1 2013
Authentication protocol	WPA2-PSK
Encryption	CCMP
Wireless transmission protocol	IEEE 802.11 a/g/n
Reach	Max. 30m (100 ft) between ClickShare Button and ClickShare Base Unit
Band	2.4 GHZ and 5 GHz
Connections	1x Ethernet LAN 4x (back) + 1x (front) USB Analog line out on mini jack socket (3.5mm) Analog line in on mini jack socket (3.5mm) <i>(audio available through software update by Q1 2013)</i>
Temperature range	Operating: +5°C to +40°C (+41°F to +104°F) Storage: -20°C to +60°C (-4°F to +140°F)
Humidity	Storage: 0 to 90% relative humidity, non-condensing Operation: 0 to 85% relative humidity, non-condensing
Altitude	Max 3000m (9842 ft)
Lifetime	<ul style="list-style-type: none"> ■ Environment: Ground Benign ■ Temperature: 25°C ■ Method: MIL-HDBK-217F Notice 2
System requirements	<ul style="list-style-type: none"> ■ CPU: Intel Pentium Dual Core E2140 – 2 * 1600 Mhz (or equivalent: AMD Athlon 64 X2 3800+ - 2 * 2000 Mhz) ■ Memory: 1024 MB RAM ■ OS: Windows XP Pro/Home (SP3) (Windows Vista/7 supported, but requires more RAM)
ClickShare Base Unit dimensions	
Dimensions (HxWxD)	181mm (incl. antennas) x 260mm x 276mm (Min.) / 7.125" (incl. antennas) x 10.236" x 10.9" (Min.)
Weight	2.6 kg/5.75 lb

CABLE TV TUNER - SULLIVAN CHAMBER**AVT 100**

TV AND CABLE DEMODULATOR

- High performance demodulator for TV/cable tuning
- Preset channel memories
- NTSC and PAL versions
- Balanced or unbalanced stereo audio output
- RS-232 control
- Optional IR remote
- Versatile mounting options



The Extron AVT 100 is a high performance analog television and cable demodulator available in NTSC and PAL versions. With control features such as selective channel access, the AVT 100 is ideal for use in boardrooms, conference rooms, and classrooms.



Extron® Electronics
 Audiovisual Program

www.extron.com Page 55

DESCRIPTION

The Extron AVT 100 is a compact, high performance analog cable and television demodulator designed to provide maximum performance and control in professional A/V environments. Primary applications include boardrooms, conference rooms, and classrooms. The AVT 100 can also be employed in large-area RF distribution systems in stadiums, arenas, and campus CCTV systems.

Channels may be selected directly from the front panel, which includes a three-digit alphanumeric display. Expanded control is available via RS-232 with Extron SIS™ - Simple Instruction Set, as well as extended range IR operation with the optional IR remote.

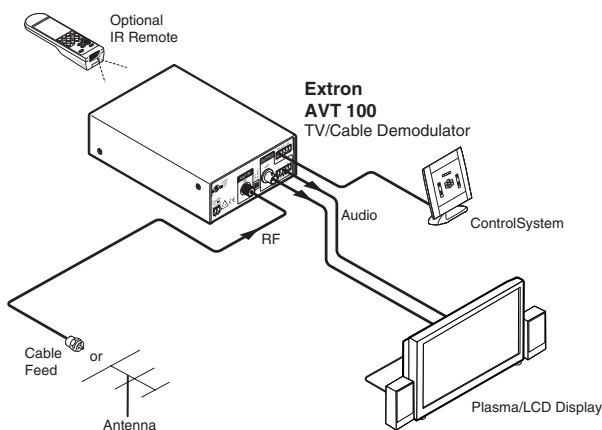
The AVT 100 can be set for full or selective channel access. Configuration settings for channel presets can be exported to a file and then uploaded to other units, saving installation time.

The AVT 100 is available in both NTSC and PAL versions, and is housed in a 1U, quarter rack width metal enclosure.

FEATURES

- High performance analog cable and TV demodulator
- Balanced or unbalanced stereo audio output on captive screw connectors
- Front panel, RS-232, and modulated IR control
- Save and recall configuration files via RS-232
- AVT 100N NTSC and AVT 100P PAL versions
- Preset channel memories
- RS-232 serial control with Extron SIS™ - Simple Instruction Set
- Optional AVT 100 IR remote control, part # 70-366-01
- Back panel IR input for modulated IR
- Rack-mountable 1U, quarter rack width metal enclosure
- External international power supply included, part # 70-055-01

APPLICATION DIAGRAM



SPECIFICATIONS

RF INPUT

Number/signal type.....	1 radio frequency (RF)
Connectors	
NTSC 3.58 model.....	1 female F connector
International model.....	1 female IEC 169-2, 75 ohm connector
Sensitivity	-20 to +20 dBmV
Frequency range.....	55 MHz to 802 MHz
Off air TV channels.....	2 to 69
CATV cable channels.....	2 to 125
Impedance	75 ohms
Vertical frequency	
NTSC model.....	60 Hz
International model.....	50 Hz

VIDEO OUTPUT

Number/signal type.....	1 composite video
Connectors	1 BNC female
Nominal level	1 Vp-p for composite video
Minimum/maximum levels	0.4 V to 1.0 Vp-p (follows input)
Impedance	75 ohms
DC offset	±10 mV with input at 0 offset

AUDIO OUTPUT

Gain	Unbalanced/balanced output: 0 dB
THD + Noise.....	0.2% @ 1 kHz at 100% modulation
S/N	65 DIN weighting
Stereo channel separation.....	>20 dB @ 1 kHz
Number/signal type.....	1 stereo, balanced/unbalanced
Connectors	(1) 3.5 mm captive screw connector, 5 pole
Impedance	50 ohms unbalanced, 100 ohms balanced
Gain error.....	±0.1 dB channel to channel
Nominal level	0 dBu
Level at 100% modulation.....	>+4 dBu, balanced at 0.2% THD+N (min.), 0.3% THD+N (typical), 1% THD+N (max.) >-6 dBV, unbalanced at 0.2% THD+N (max.)

CONTROL/REMOTE

Serial control port.....	RS-232; 3.5 mm captive screw connector, 5 pole
Baud rate and protocol	9600 baud, 8 data bits, 1 stop bit, no parity
Serial/IR control pin configurations	1 = TX, 2 = RX, 3 = GND, 4 = modulated IR, 5 = +12 VDC
IR controller module	IR 501 (optional), 30' maximum, 40 degrees off axis
Program control	Extron's control/configuration program for Windows® Extron's Simple Instruction Set (SIS™)

GENERAL

External power supply	100 VAC to 240 VAC, 50/60 Hz, external, autoswitchable; to 12 VDC, 1 A, regulated
Power input requirements.....	12 VDC, 0.5 A
Rack mount	Yes, with optional 1U rack shelf, part #60-190-01 or 60-604-01
Enclosure type	Metal
Enclosure dimensions.....	1.7" H x 4.3" W x 6.7" D (1U high, quarter rack wide) 4.3 cm H x 10.9 cm W x 17.0 cm D (Depth excludes connectors.)
Product/Shipping weight.....	0.8 lbs (0.4 kg) / 3 lbs (2 kg)
Listings	UL, CUL
Compliances.....	CE, FCC Class A, VCCI, AS/NZS, ICES

NOTE: All nominal levels are at ±10%

Model	Version Description	Part Number
AVT 100 NTSC	NTSC.....	60-647-01
AVT 100 PAL	PAL.....	60-647-02
Optional Accessories		
AVT Remote	Handheld IR Remote Control for the AVT 100	70-366-01
IR Link	Wall-Mountable IR Signal Repeater - Black.....	60-404-02
RSU 129	1U 9.5" Deep Universal Rack Shelf Kit.....	60-190-01
PMK 100	1/4 Rack Width Mini Projector Mount Kit.....	70-217-01

Specifications are subject to change without notice.



Extron Electronics, USA
1230 South Lewis Street
Anaheim, CA 92805
800.633.9876 714.491.1500
FAX 714.491.1517

Extron Electronics, Europe
Beeldschermweg 6C, 3821 AH Amersfoort
The Netherlands
+800.3987.6673 +31.33.453.4040
FAX +31.33.453.4050

Extron Electronics, Asia
135 Joo Seng Rd. #04-01
PM Industrial Bldg.
Singapore 368363
+65.6383.4400 FAX +65.6383.4664

Extron Electronics, Japan
Kyodo Building, 16 Ichibancho
Chiyoda-ku, Tokyo 102-0082
Japan
+81.3.3511.7655 FAX +81.3.3511.7656

Smart operation with IP control

An Integrated Pan-tilt HD/SD Camera for a Wide Range of Shooting Conditions

new

HD Integrated Camera

For indoor use

AW-HE120WP/WE/KP/KE

- Full HD 3MOS
- HD/SD
- 20x optical zoom
- 10x digital zoom
- IP/Serial control
- DRS
- Turn-Lock mounting mechanism
- 60Hz/50Hz switchable

HD 1080/59.94p (HDMI only), 59.94i, 50p (HDMI only), 50i, 720/59.94p, 50p,

SD 576/50p (HDMI only), 50i, 480/59.94p (HDMI only), 59.94i



AW-HE120WP/WE (White Model)
*Suspended (Hanging) style

AW-HE120KP/KE (Black Model)
*Stand-alone (Desktop) style

Option		Wireless remote control AW-RM50G ■ "R6" or "LR6" battery × 2 are not included.		Direct Ceiling Mount Bracket WW-Q105
---------------	--	---	--	--

System example

HD/SD camera system

Ideal for shooting in large places such as concert halls and government chambers.

Key Points

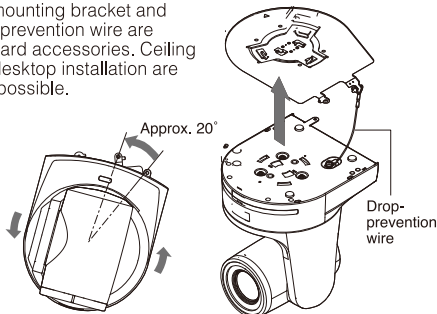
- Up to a hundred AW-HE120WP/WE/KP/KE units can be controlled by AW-RP50N/E via IP connections when using Ethernet hubs.

[Key Products]

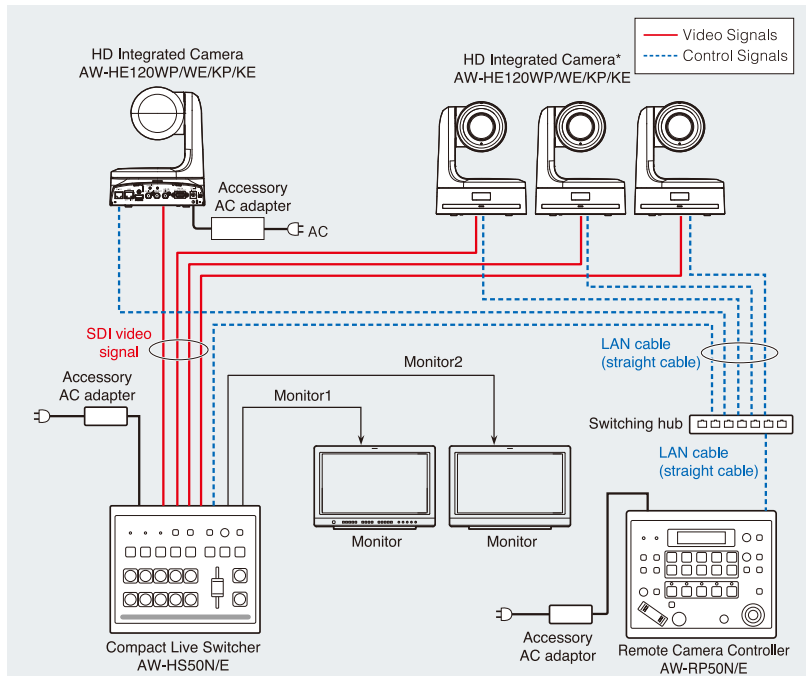
AW-HE120WP/WE/KP/KE AW-HS50N/E AW-RP50N/E

Optimal for both hanging and desktop installation.

The mounting bracket and drop-prevention wire are standard accessories. Ceiling and desktop installation are both possible.



* Wiring, mounting, and removal must be done by a qualified technician. To ensure safety, consult with the dealer from whom you purchased the system.



*The AC adaptor provided with the unit is not shown in the above figure.

Integrated Pan-tilt Camera with a Compact Body and Simple System Configuration.

Both SDI and HDMI are supported, and IP connection enables flexible system configuration, easy connection and settings. It can also be connected to current camera controllers. Both size and weight have been reduced by approximately 60% compared to our previous model (the AW-HE100), to achieve a lightweight, compact body. With its sleek design and color variation, it blends with atmospheres in a variety of situations.



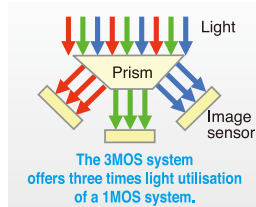
Compared with the previous AW-HE100 model.

Shoot High-Quality Images with 1/3 Type Full-HD "U.L.T." 3MOS Image Sensors.

•Ultra Luminance Technology

High resolution and high image quality are produced by the newly developed 1/3 type 2.2 mega pixels "U.L.T." 3MOS sensors and digital signal processor (DSP).

The 3MOS System uses three MOS sensors to process the three primary colors (R, G, B) of light. (MOS = Metal Oxide Semiconductor)



A 20x Optical Zoom Lens Covers Wide-Angle to Ultra Telephoto Shots.

In addition to a wide-angle design that features 32.13mm (35mm equivalent) at the wide end and a 20x optical zoom lens, a 10x digital zoom provided. This lets you shoot a wide variety of sharp and crisp images from wide angle to close up.



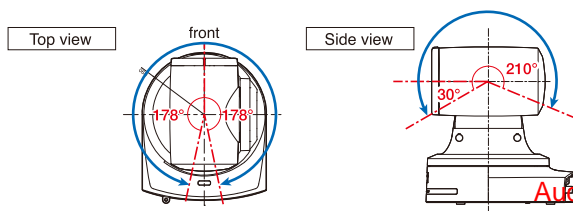
From wide angle to telescopic shots - the cameras deliver clear and crisp images for a wide range of applications.

(Photos are simulated.)

A Wide Range Pan-tilt, High-Speed Control, and Silent Design apply for Versatile Operations.

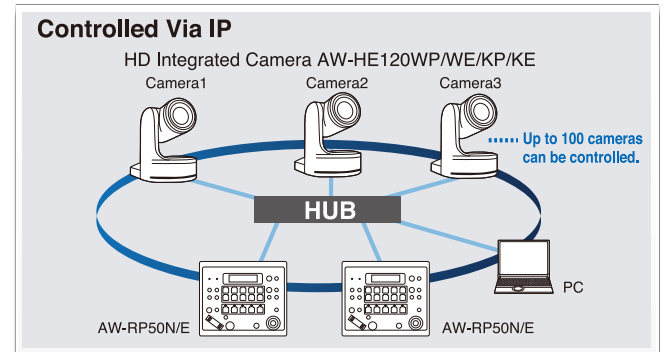
More smooth and natural movement is achieved for the pan-tilt operation. The pan-tilt head also allows a wide range* shooting, with a pan range of $\pm 175^\circ$ and a tilt range of -30° to 210° . The newly developed pan tilt drive provides high-speed operation at maximum 60°/s, excellent response from remote control operation, and highly precise stop control. These features combine to accurately capture fast-action sports scenes with comfortable remote shooting. The noise level during operation is also very low, at NC35 or less, which is ideal for shooting in concert halls.

* Depending on the position of the pan and tilt, its own unit may be reflected in the image.



IP Control Provides Easy Connection and Settings for Comfortable Camera Control.

Up to 100 AW-HE120WP/WE/KP/KE units can be controlled from the AW-RP50N/E through a Ethernet HUB using the IP connection. IP connection also allows one AW-HE120WP/WE/KP/KE to be controlled simultaneously from up to five AW-RP50N/E units.



Dynamic Range Stretch (DRS) automatically optimizes images that have a wide contrast range.

A gamma curve and knee slope are estimated to match the contrast of each pixel, in real time. When dark, bright, and intermediate areas are all contained in the same scene, this function produces excellent gradation for each area and minimizes blocked shadows and blown highlights. The images of results are enhanced by a visually wider dynamic range.



DRS OFF

With the iris expanded, this blown highlight appears on the blackboard.



DRS OFF

With the iris contracted, a blocked shadow appears on the figure.



DRS ON

Both highlights and shadows are clearly visible.

(Photos are simulated.)

Other features

● Setting camera menus with a PC.

Camera menus can be set up via a web browser by connecting the AW-HE120WP/WE/KP/KE to a PC.

● Wireless remote controller for easy operation (option).

Up to 4 cameras can be controlled by an optional wireless remote controller (AW-RM50G). Functional setting and change can also be adjusted via wireless remote controller.

● Simple connection and installation enable a flexible camera layout.

IP control, a lightweight body, and the turn-lock mounting mechanism enable easy connection and mounting by a single person (indoor mounting only).

● Compact design for energy-saving.

The compact, lightweight body realizes low power consumption and low cost operation of multiple cameras.

Specifications

		AW-HE120WP/WE/KP/KE		
General	Power Requirements	DC 12 V (AC adaptor supplied)		
	Power Consumption	1.75 A		
	Operating Temperature	0°C to 40°C (32°F to 104°F)		
	Allowable Humidity Range	35 % to 90 % (no condensation)		
	Storage Temperature	-20°C to 50°C (-4°F to 122°F)		
	Weight	Approx.3.0 kg (Approx 6.61 lbs) (Including mount bracket)		
	Dimensions (W x H x D)	180 mm x 228 mm x 220 mm (7-3/32 inches x 8-31/32 inches x 8-21/32 inches) (excluding protrusions, cable cover, direct ceiling mount bracket)		
Camera	Image Sensors	1/3 type Full-HD 3MOS		
	Lens	Motorized 20x zoom, F1.6 to F3.4 (f=4.5 mm to 90 mm; 35 mm equivalent:32.13 mm to 642.5 mm)		
	Focus	Switching between auto and manual		
	Focus distance	Entire zooming range:800 mm. Wide end:400 mm		
	Color Separation Optical System	3MOS		
	Minimum Illumination	7 lx (50 IRE, F1.6, +18 dB)		
	Horizontal Resolution	1 000 TV lines Typ (Center area)		
	Gain Selection	Auto, 0 dB to 18 dB		
	Frame Mix ¹	0 dB, 6 dB, 12 dB, 18 dB, 24 dB		
	Electronic Shutter Speed	59.94 Hz	1/100, 1/250, 1/500, 1/1000, 1/2000, 1/4000, 1/10000	
		50 Hz	1/120, 1/250, 1/500, 1/1000, 1/2000, 1/4000, 1/10000	
	SynchroScan	59.94 Hz	60.17 Hz to 644.26 Hz	
		50 Hz	50.19 Hz to 537.13 Hz	
Gamma	Off, Normal (Low, Mid, High), Cinema			
White Balance	AWB A, AWB B, ATW, 3 200K, 5 600K			
Camera	Scene File	Scene1, Scene2, Scene3,Scene4		
	Output Format	HD	1080/59.94p ² , 1080/59.94i, 1080/50p ² , 1080/50i	
SD		576/50p ² , 576/50i, 480/59.94p ² , 480/59.94i		
Camera	Synchronization System	Internal/External synchronization (BBS/Tri-level sync)		
	Input Connector	DC 12 V IN, G/L IN (BNC×1) ³ *BBS (Black Burst Sync), tri-level sync supported		
Output	HDMI	HDMI×1		
	HD/SD SDI OUT	BNC×1 Compliant with the SMPTE292M/SMPTE259M standards/75 Ω		
	VIDEO OUT	BNC×1 NTSC/PAL 1.0 V[p-p]/75 Ω		
Output	HD/SD ANALOG OUT	Y/Pa/Pb or R/G/B D-sub 15 pin x 1		
	Input/Output Connector	LAN	LAN connector for IP control (RJ-45)	
RS-422		CONTROL IN RS422A (RJ-45)		
Pan-Tilt Mechanism	Pan/Tilt Operation Speed	MAX 60°/s		
	Panning Range	±175°		
	Tilting Range ⁴	-30° to 210°		
	Quietness	NC35		
Standard Accessories		Mount bracket for installation surface (Hanging ⁵ / Desktop) Drop-prevention wire, Drop-prevention wire mounting screw (already attached to the unit), Bracket mounting screws (bind-head) M4 x 10 mm, Main unit mounting screw (with flat washer, spring washer) M3 x 6 mm, Cable cover, Power cable (1.8 m [5.9 ft]), AC adaptor		

*1 Cannot be set when using 1080/59.94i nor 1080/50i formats.

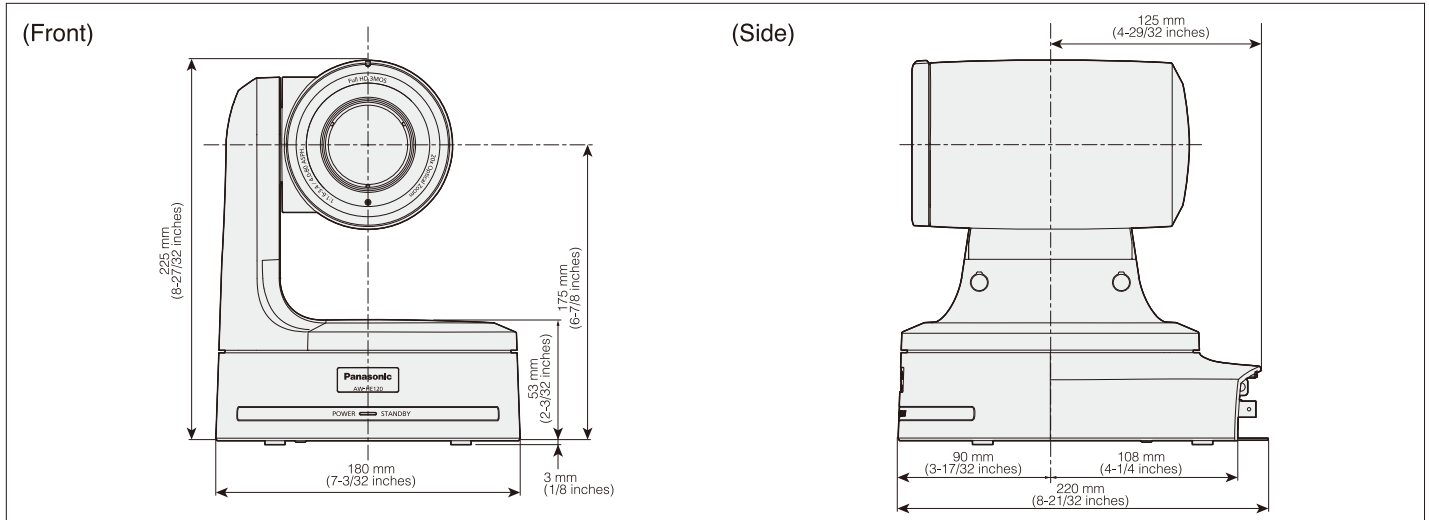
*2 When 1080/59.94p, 1080/50p, 480/59.94p, or 576/50p mode is selected, a Progressive signal is output to HDMI and an Interlace signal is output to SDI and analog component outputs.

*3 Supports BBS (Black Burst Sync) and Tri-level Sync. BBS does not allow locking of the color subcarrier.

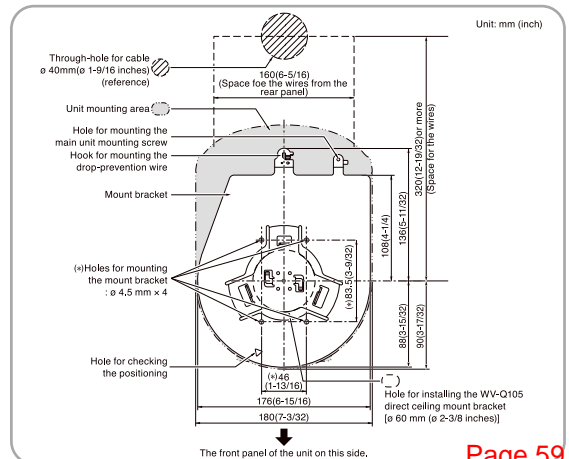
*4 The camera may be subject to external glare, depending on the pan and tilt position.

*5 To ensure more safety, AW-HE120WP/WE/KP/KE can be secured by using the direct ceiling mount bracket (WV-Q105).

Dimensions



Rear view



Small Size and High Quality
Integrated Pan-Tilt HD/SD Cameras
 with SDI and HDMI models.

HD Integrated Camera For indoor use
AW-HE50HN/HE [HDMI Model]

HD Integrated Camera For indoor use
AW-HE50SN/SE [SDI Model]

- Full HD
MOS
- HD/SD
- 18x
optical zoom
- 10x
digital zoom
- IP/Serial
control
- DRS
- Turn-lock
mounting
mechanism

HD 1080/59.94i, 50i, 720/59.94p, 50p

SD 576/50i, 480/59.94i



Suspended (Hanging) style

Stand-alone (Desktop) style

Option

Upgrade Kit
AW-HEF5SG [for AW-HE50SN/SE]
AW-HEF5HG [for AW-HE50HN/HE]

- [Effect of AW-HEF5SG/HG]**
- R-Gain and G-Gain are adjustable independently.
 - 16 axis Color Matrix setup function.
 - 1080/29.97PsF (NTSC) and 1080/25PsF (PAL) are added in format selection.
 - 1080/59.94p (NTSC) and 1080/50p (PAL) are added in format selection. (AW-HE50HN/HE only)

Option



Wireless remote control
AW-RM50Q

■ "R6" or "LR6" battery x 2, are not included.



Direct Ceiling Mount Bracket
WW-Q105

Multi-interface Cable **AW-CA20T6G**

System example

HD/SD camera system

For small or medium scale shooting, such as education, businesses and wedding halls.

Key Points

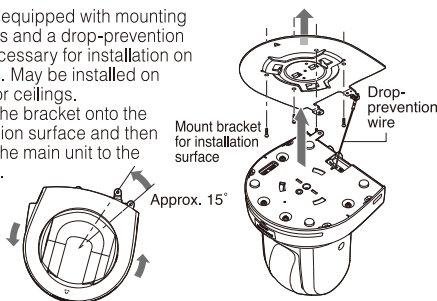
- Up to 100 x AW-HE50HN/HE/SN/SE units can be controlled by AW-RP50N/E via IP connections through Ethernet hubs.

[Key Products]

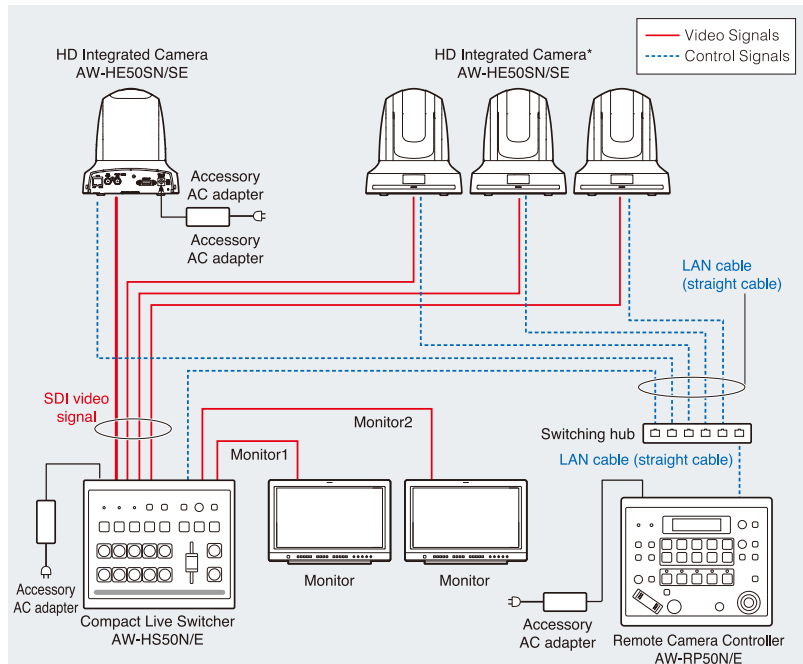
AW-HE50SN/SE AW-HS50N/E AW-RP50N/E

Optimal for both hanging and desktop installation.

Comes equipped with mounting brackets and a drop-prevention wire necessary for installation on ceilings. May be installed on tables or ceilings. Mount the bracket onto the installation surface and then attach the main unit to the bracket.



* Wiring, mounting, and removal must be done by a qualified technician. To ensure safety, consult with the dealer from whom you purchased the system.



*The AC adapter provided with the unit is not shown in the above figure.

Camera, lens and pan-tilt in one compact, lightweight body.

The lineup consists of two models, the AW-HE50SN/SE SDI model, which is optimal for content production, and the AW-HE50HN/HE HDMI model, which is ideal for image distribution in situations such as videoconferences. In addition to IP control, both models can be connected to existing controllers with serial control. An attractive form that blends with its surroundings and a cable cover that minimizes clutter allow shooting without adversely affecting the mood of the installation location.



1/3 type Full-HD MOS sensor and high-performance zoom lens.

The cameras are equipped with the newly developed 1/3 type Full-HD MOS sensor and digital signal processor (DSP). Shoots clear, crisp HD video even in environments with less light (minimum illumination of up to 3 lx). In addition to the 18x optical zoom lens, the camera features a 10x digital zoom. This makes it possible to shoot a wide variety of sharp and crisp images, from wide angle to close up face.

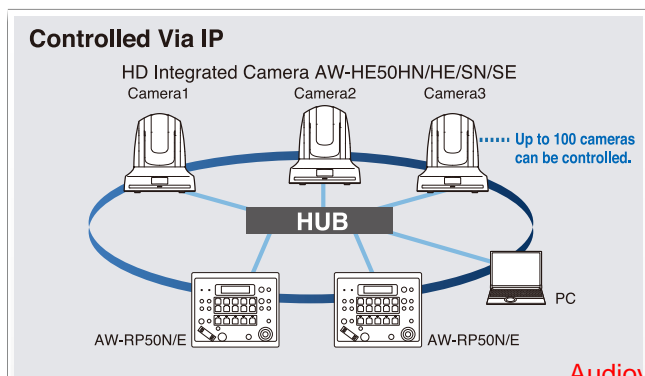


From wide angle to telescopic shots - the cameras deliver clear and crisp images for a wide range of applications.

(Photos are simulated.)

IP Control Provides Easy Connection and Settings for Comfortable Camera Control.

Up to 100 AW-HE50HN/HE/SN/SE units can be controlled from the AW-RP50N/E through a Ethernet HUB using the IP connection. IP connection also allows one AW-HE50 to be controlled simultaneously from up to five AW-RP50N/E units.



Dynamic Range Stretch (DRS) automatically optimizes images that have a wide contrast range.

A gamma curve and knee slope are estimated to match the contrast of each pixel, in real time. When dark, bright, and intermediate areas are all contained in the same scene, this function produces excellent gradation for each area and minimizes blocked shadows and blown highlights. The images of results are enhanced by a visually wider dynamic range.



DRS OFF

With the iris expanded, this blown highlight appears on the blackboard.



DRS OFF

With the iris contracted, a blocked shadow appears on the figure.



DRS ON

Both highlights and shadows are clearly visible.

(Photos are simulated.)

Hybrid (2D/3D) Noise Reduction

The innovative Hybrid (2D/3D) Noise Reduction function also suppresses afterimages, even in difficult lighting conditions.



Without Noise Reduction

Some noise appear when gain control is turned up.



3D Noise Reduction Alone

Afterimage and some loss of resolution appear.



The Hybrid (2D/3D) Noise Reduction

Clearer images in difficult conditions.

(Photos are simulated.)

Other features

Setting camera menus with a PC.

Camera menu can be set up via a web browser by connecting the AW-HE50HN/HE/SN/SE to a PC.

Wireless remote controller for easy operation (option).

Up to 4 cameras can be controlled by an optional wireless remote controller (AW-RM50G). Functional setting and change can also be adjusted via wireless remote controller.

Simple connection and installation enable a flexible camera layout.

IP control, a lightweight body, and the turn-lock mounting mechanism enable easy connection and mounting by a single person (indoor mounting only).

Compact design for energy-saving.

The compact, lightweight body realizes low power consumption and low cost operation of multiple cameras.

Specifications

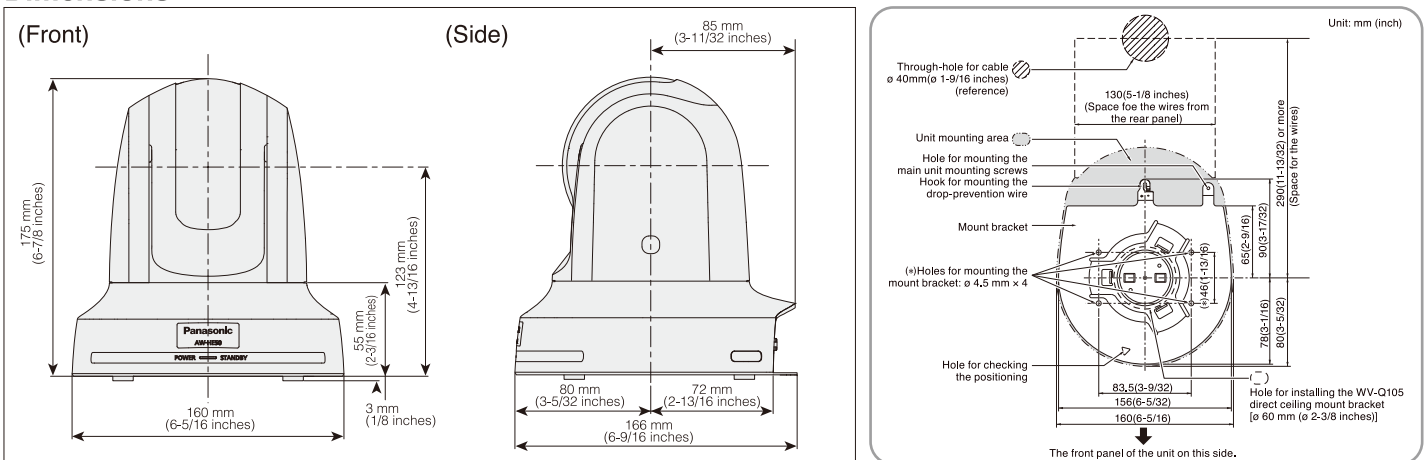
		AW-HE50HN/SN	AW-HE50HE/SE	
General	Power Requirements	DC 12 V ±10 % (AC adaptor supplied)		
	Power Consumption	1.2 A (AW-HE50H), 1.3 A (AW-HE50S)		
	Operating Temperature	0°C to 40°C (32°F to 104°F)		
	Allowable Humidity Range	20 % to 90 % (no condensation)		
	Storage Temperature	-20°C to 50°C (-4°F to 122°F)		
	Weight	Approx.1.4 kg (Approx.3.1 lbs)		
	Dimensions (W x H x D)	160 mm x 178 mm x 166 mm (6-5/16 inches x 7 inches x 6-9/16 inches) (excluding protrusions, cable cover, direct ceiling mount bracket)		
	Image Sensors	1/3 type Full-HD MOS		
Camera	Lens	Motorized 18x zoom,F1.6 to F2.8 (f=4.7 mm to 84.6 mm; 35 mm equivalent:36.9 mm to 664.5 mm)		
	Focus	Switching between auto and manual		
	Focus distance	Entire zooming range: 1.5 m (4.9 ft.), Wide end: 30 cm (0.98 ft.)		
	Color Separation Optical System	On-chip color filter system		
	Minimum Illumination	3 lx (50 IRE, F1.6, +36 dB)		
	Horizontal Resolution	850 TV lines Typ (Center area)		
	Gain Selection	Auto, 0 dB, 3 dB, 6 dB, 9 dB, 12 dB, 15 dB, 18 dB		
	Frame Mix	0 dB, 6 dB, 12 dB, 18 dB		
	Electronic Shutter Speed	1/100, 1/250, 1/500, 1/1000, 1/2000, 1/4000, 1/10000	1/120, 1/250, 1/500, 1/1000, 1/2000, 1/4000, 1/10000	
	Synchro Scan	60.24 Hz to 646.21 Hz	50.20 Hz to 538.51 Hz	
	Gamma	Off, Normal (Low, Mid, High), Cinema		
	White Balance	AWB A, AWB B, ATW		
	Scene File	FullAuto, Manual1, Manual2, Manual3		
	Output Format	HD SD	1080/59.94i, 720/59.94p 480/59.94i	1080/50i, 720/50p 576/50i
Synchronization System	Internal synchronization (AW-HE50H), Internal/External Synchronization (BBS) (AW-HE50S)			
Input Connector	DC 12 V IN, EXT SYNC IN (BNC) (AW-HE50S only) *BBS (Black Burst Sync) signal supported			
Output Connector	HDMI	HDMIx1 (AW-HE50H)		
	SDI	BNCx1 Compliant with the SMPTE292M/SMPTE259M standards / 75 Ω (AW-HE50S)		
	Composite	MULTI-I/Fx1 1.0 V [p-p] / 75 Ω		
	Y/Pa/Pb(HD/SD)	MULTI-I/Fx1 Y:1.0 V[p-p]/75 Ω, PB/PR:0.7V[p-p]/75 Ω *For Y/Pa/Pb, the 1080, 720 or SD format is selected depending on the format setting.		
Input/Output Connector	LAN	LAN connector for IP control (RJ-45)		
	RS-422	MULTI-I/Fx1 CONTROL IN RS422A*1		
Pan-Tilt Mechanism	Pan/Tilt Operation Speed	MAX 90°/s		
	Panning Range	±175°		
	Tilting Range*2	90° to -30°		
	Quietness	NC35 (at normal speed), NC40 (at fastest speed when preset)		
Standard Accessories	Mount bracket for installation surface (Hanging ³ /Desktop), Drop-prevention wire (already attached to the unit), Bracket mounting screws (bind-head) M4 x 10 mm, Main unit mounting screw (with flat washer ,spring washer)M3 x 6 mm, Cable cover, Power cable (2 m[6.6 ft]), AC adaptor			

*1 Multi-interface Cable (AW-CA20T6G) is required.

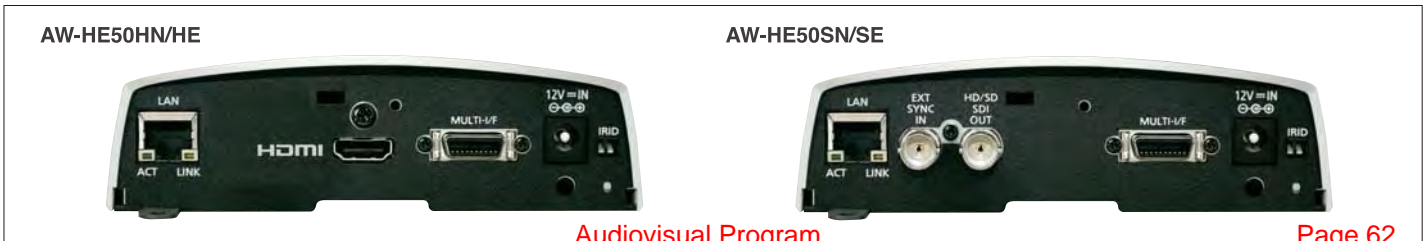
*2 The camera may be subject to external glare, depending on the pan and tilt position.

*3 To ensure more safety, AW-HE50HN/HE/SN/SE can be secured by using the direct ceiling mount bracket (WV-Q105).

Dimensions



Rear view



CAMERA MONITORS - SULLIVAN CHAMBER

V-MD563

Triple 3RU 5.6" High Resolution LCD Rack Mount Monitor with Modular Inputs/Outputs



[ENLARGE IMAGE](#)

OVERVIEW NETWORK CONTROL FALSE COLOR FILTER IMD & TALLY OPTIONAL MODULES

Marshall Electronics proudly presents the MD series of rack mount monitors that offer a flexible modular solution to system integration. These new rack-mountable monitors can be configured with a variety of video inputs that can be "swapped" or interchanged in the field based on your evolving needs and requirements. This eliminates the need to upgrade or replace equipment when a different input or application is required. This "future proof" solution provides flexibility and reassurance when necessary, especially in multi-monitor rack mount units.

The V-MD563 offers three high resolution 1280 x 800 LED-backlit LCDs in one single configuration, along with excellent viewing angles. The V-MD563 includes Composite and Component loop-through, Status Display, False Color Filter, Markers, Freeze Function, Color Temperature Presets, RGB Gain / Bias Adjust, Pixel-to-Pixel, Blue Gun, Hard Tally, four user-definable function buttons, and more. A variety of modules will become available including the availability of 3G/HD/SDI with loop-through, Fiber-Optic Input/output modules, and more.

Marshall's new MD monitors integrate Telecast Fiber System's TeleCube™ Fiber-Optic HD/SDI transmission input/output modules. These new fiber modules deliver the industry's broadest range of digital rates while maintaining pristine signal quality that broadcasters and integrators demand.

\$3599.00

SPECIFICATIONS

Display (Viewing Area)	5.6" x 3
Resolution (Pixels)	1280 x 800
Aspect Ratio	16:10
Pixel Pitch (h x v)	TBD
Brightness (in cd/m ²)	300
Contrast Ratio	500:1
Standard Inputs	Composite, Component
Available # of Optional Input Slots	1 (per screen)
Dimensions	19" x 5.2" x 1.3"
Weight	4 lbs.
Power Consumption	3 Amp @ 12VDC

* Pricing does not reflect freight costs and applicable taxes and duties

* Pricing, specification and features are subject to change

PROGRAM MONITOR - SULLIVAN CHAMBER

Marshall Camera-Top Monitors for Video and DSLR Cameras

[HOME](#) » [Monitors](#) » VMD171XN

V-MD171XN

6RU 17" Full Resolution Rack Mount / Standalone Monitor with Modular Inputs



- [Overview](#)
- [Tech Specs](#)
- [Features](#)
- [Gallery](#)
- [Modules](#)



- 1920 x 1200 Full Resolution Panel
- Flexible "future proof" solution
- World's 1st HD Monitor with Fiber-Optic Input
- Swap and interchange modular inputs at any time
- Choose from a variety of inputs including 3G-SDI and Fiber
- Multi-format Compatibility
- False Color Filter
- Thin mechanical design

Marshall Electronics proudly presents the MD series of rack mount monitors that offer a flexible modular solution to system integration. These new rack-mountable monitors can be configured with a variety of video inputs that can be "swapped" or interchanged in the field based on your evolving needs and requirements. This eliminates the need to upgrade or replace equipment when a different input or application is required. This "future proof" solution provides flexibility and reassurance when necessary, especially in multi-monitor rack mount units.



\$55.95

Optional Accessory:

V-ST15

Optional Desktop Stand

[More Accessories](#)

The V-MD171XN includes Composite and Component loop-through, Status Display, False Color Filter, Markers, Freeze Function, Color Temperature Presets, RGB Gain / Bias Adjust, Pixel-to-Pixel, Blue Gun, Hard Tally, user-definable function buttons, and more. A variety of modules will become available including the availability of 3G/HD/SDI with loop-through, Fiber-Optic input/output modules, and more.

The V-MD171XN can be used as a standalone monitor without the rack ears attached or mounted in any standard EIA 19" equipment rack. The attached rack ears can be angled to provide the user control over the viewing angle. A VESA standard 75mm hole pattern also allows custom mounting installations. Alternately, the V-MD171XN can be used in a desktop configuration with optional stand (Marshall part number V-ST15).

The MD Series monitors are the WORLD'S FIRST HD MONITORS WITH DIRECT FIBER OPTIC VIDEO INPUTS. Marshall's new MD monitors integrate Telecast Fiber System's TeleCube™ Fiber-Optic HD/SDI transmission input/output modules. These new fiber modules deliver the industry's broadest range of digital rates while maintaining pristine signal quality that broadcasters and integrators demand.

With broadcast production facilities looking to the future with 3Gb/s SDI integration, Marshall fills the void with fully-featured, high-end monitors with full 3G-SDI support. For distances beyond 150 meters, fiber-optic signaling may be required. To fulfil this need, Marshall looked to Telecast Fiber Systems, the company that developed fiber-optic video technology for television broadcast production. Telecast's comprehensive systems are used worldwide.

The V-MD171XN received TV Technology's STAR (Superior Technology Award Recipient) at IBC 2009 in Amsterdam. These awards are designed to celebrate and showcase the preeminent technological innovations available to the media industry. A panel of judges consisting of TV Technology editors and columnists reviewed a variety of products and services, examined the technical applications and their overall contribution to the industry, and then submitted their award nominees.

[Contact](#) [Careers](#) © 2013 [Marshall Electronics](#)

Price: \$2299.00

PREVIEW/WAVEFORM MONITOR - SULLIVAN CHAMBER

Marshall Camera-Top Monitors for Video and DSLR Cameras

[HOME](#) » [Monitors](#) » V-R171X-DLW

V-R171X-DLW

17" Full Resolution Dual Link / Waveform Monitor



- [Overview](#)
- [Tech Specs](#)
- [Features](#)
- [Gallery](#)



\$55.95

Optional Accessory:

V-ST15

Optional Desktop Stand

[More Accessories](#)

Marshall Electronics introduces the new DLW Series to the expanding line of IMD (In-Monitor Display) Monitors. The 17" V-R171X-DLW and the 26" V-R261-DLW IMD monitors include Dual Link with Waveform & Vectorscope. These new models incorporate a 10-bit "no compromise" video path along with one of the industry's first monitors equipped with 3G capability. In Quad-View mode, the monitors break the screen into four quadrants and display Audio Bars, a Waveform Monitor, Vectorscope, and live video simultaneously. Both models have two inputs supporting 3G / HD / SDI and Dual Link. A DVI input supports all HDMI modes and DVI to 170MHz.

Marshall's IMD monitors are a cost-effective "all-in-one" solution for post production houses, broadcasters, and mobile units. This fully-integrated approach eliminates the need for additional or separate Under Monitor Displays and allows UMD information and tallies to be displayed directly within a Marshall flat panel monitor, while saving precious rack space. These new monitors also offer our RotoMenu™ feature which allows fast, direct, and easy menu navigation. This 6RU unit also ships ready to rack mount and can be wall or ceiling mounted with an optional VESA adapter.

Price: \$3999.00

[Download Manual](#)

[Contact](#) [Careers](#) © 2013 [Marshall Electronics](#)

Panasonic
ideas for life

AW-RP120G

Remote Camera Controller

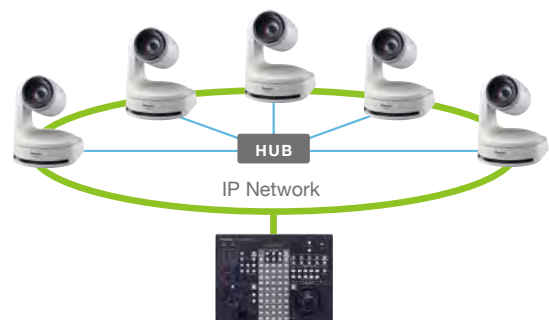
Preliminary



IP Connection and Control of Up to 100 Remote Cameras. Highly Functional Remote Controller with New Joystick and Other Operating Enhancements.

The AW-RP120G Remote Camera Controller supports a variety of Panasonic remote camera systems. IP connection allows a large-scale, flexible, and simple system configuration for controlling up to 100 remote cameras and the simultaneous use of multiple controllers. A new joystick enables high-response pan and tilt operation, and a newly designed control panel adds color adjustment dials. A preset memory with a new batch recall function and tracing memory save labor by allowing single-person operation.

Equipped with Paint and other camera adjustment functions, the AW-RP120G meets a wide range of high-end needs. It is the ideal all-in-one controller for many applications such as event, conference hall, public facility, wedding and broadcasting use.



IP Connection and Control of Up to 100 Remote Cameras

- **IP connection:** Up to 100 remote cameras can be connected and controlled via a switching hub. Automatic IP allocation simplifies the configuration of large-scale systems.
- **Multi-control:** IP connection allows five AW-RP120G controllers to simultaneously control one remote camera.
- **Serial control compatibility:** Up to five remote cameras can be connected and controlled. Also compatible with existing systems, and an RS232C port enables external control.
- **AW-HS50N/E linking:** IP connection allows linking with an AW-HS50N/E Compact Live Switcher, for a highly efficient operating environment.

High-Response Pan, Tilt, Zoom and Memory Functions

- **Newly designed control panel:** Features a pan/tilt joystick, seesaw zoom lever, focus dial, and iris dial. A special speed adjustment dial is provided for each of the pan/tilt, zoom and focus functions.
- **Tracing memory:** The remote camera operations (pan, tilt, zoom, focus, iris, and white balance modes) can be memorized and recalled. Up to ten memory items can be stored for each camera.
- **Preset memory:** Up to 100 camera angle settings (pan, tilt, zoom operation) can be registered and retrieved for each camera to greatly simplify a variety of camera controls.
- **New preset batch retrieval function:** By creating groups of any desired preset memories (up to four groups), multiple camera angle settings (up to ten cameras) can be retrieved in a single batch. This enables one-touch control of routine operations.

Image Adjustments, Easy Operation and Versatile Functions

- **Camera image adjustments:** Gain, Shutter, Detail, AWB, ABB, Master Pedestal, R/B Pedestal, and R/B Gain can be adjusted.
- **Direct selection buttons:** Features ten camera selection buttons. Numerical buttons (1-50) on the panel allow retrieval of 50 preset memories and ten tracing memories.
- **Zoom, focus, and iris indicator display.**
- **Equipped with an LCD panel for menu operation.**
- **Functions can be allocated to eight User buttons for one-touch ease.**
- **SCENE one to four buttons allow one-touch switching of remote camera shooting modes (Scene Files).**
- **Settings can be backed up on a SD memory card. This also allows settings to be copied to other controllers.**

Supporting Remote Camera Systems*1

(Tentative)

- **HD integrated cameras:** AW-HE50HN/HE/SN/SE, AW-HE60HN/HE/SN/SE, AW-HE120WP/WE/KP/KE, AW-HE100N/E,*2 AW-HE2P/E
- **Cameras (used with supporting pan/tilt head):** AK-HC1500G, AK-HC1800G, AW-HE870N/E, AW-E860N/L,*2, AW-E750P/E,*2, AW-E650P/E,*2, AW-E350P/E,*2
- **Pan/tilt heads:** AW-PH360N/L, AW-PH405N/E, AW-PH650N/L, AW-PH400P/E (requires AW-IF400G)

*1: Controllable items vary depending on the model. *2: Production discontinued.

Specifications

(Tentative)

Power supply:	DC 12 V
Power consumption:	8 W
Weight:	Approx. 3.1 kg (Approx. 6.9 lb)
Dimensions (W x H x D):	Approx. 342 mm x 77 mm x 265 mm (Approx. 13-1/2 inches x 3-1/16 inches x 10-7/16 inches) excluding protrusions
Connectors:	DC 12 V IN (XLR 4-pin) LAN (RJ-45) 10BASE-T/100BASE-TX, to control remote cameras SERIAL (RJ-45) RS-422, to control remote cameras x 5 TALLY/GPI (D-sub 25-pin) REMOTE (D-sub 9-pin) RS-232C, for external control



Operation Panel

Specifications and design are subject to change without notice.

Panasonic

Countries and Regions

Panasonic Corporation
Professional AV Business Unit
2-15 Matsuba-cho, Kadoma, Osaka 571-8503
Japan
<http://pro-av.panasonic.net/>

Argentina	+54 1 308 1610
Australia	+61 (0) 2 9491 7400
Bahrain	+973 252292
Belgium	+32 (0) 2 481 04 57
Brazil	+55 11 3889 4035
Canada	+1 905 624 5010
China	+86 10 6515 8828
Hong Kong	+852 2313 0888
Czech Republic	+420 236 032 552/511
Denmark	+45 43 20 08 57
Egypt	+20 2 23938151
Finland, Latvia, Lithuania, Estonia	+358 (9) 521 52 53
France	+33 (0) 1 47 91 64 00
Germany, Austria, Switzerland	+49 (0) 611 235 459
Greece	+30 210 96 92 300
Hungary	+36 (1) 382 60 60
India	+91 120 247 1000
Indonesia	+62 21 385 9449
Iran (Vida)	+98 21 2271463
(Panasonic Office)	+98 2188791102
Italy	+39 02 6788 367
Jordan	+962 6 5859801
Kazakhstan	+7 727 298 0891
Korea	+82 2 2106 6641

Kuwait	+96 522431385
Lebanon	+96 11665557
Malaysia	+60 3 7809 7888
Mexico	+52 55 5488 1000
Netherlands	+31 73 64 02 577
New Zealand	+64 9 272 0100
Norway	+47 67 91 78 00
Pakistan	+92 5370320 (SNT)
Palestine	+972 2 2988750
Panama	+507 229 2955
Peru	+51 1 614 0000
Philippines	+63 2 633 6163
Poland	+48 (22) 338 1100
Portugal	+351 21 425 77 04
Puerto Rico	+1 787 750 4300
Romania	+40 21 211 4855
Russia & CIS	+7 495 6654205
Saudi Arabia	+96 626444072
Singapore	+65 6270 0110
Slovak Republic	+421 (0) 2 52 92 14 23
Slovenia, Albania, Bulgaria, Serbia, Croatia, Bosnia, Macedonia, Montenegro	+36 (1) 382 60 60
South Africa	+27 11 3131622
Spain	+34 (93) 425 93 00
Sweden	+46 (8) 680 26 41
Syria	+963 11 2318422/4

Taiwan	+886 2 2227 6214
Thailand	+66 2 731 8888
Turkey	+90 216 578 3700
U.A.E. (for All Middle East)	+971 4 8862142
Ukraine	+380 44 4903437
U.K.	+44(0)1344 70 69 13
U.S.A.	+1 877 803 8492
Vietnam	+848 38370280



Factories of Business Solutions Business Group have received ISO14001:2004-the Environmental Management System certification. (Except for 3rd party's peripherals.)

Panasonic
ideas for life

AV-HS410

Live Switcher

(AV-HS410N, AV-HS410E)

A Rival to High-End Switchers in Performance and Ease of Operation
into a Compact, Integrated Body



High-End Performance and Functions in a Compact Body.

A User Interface Designed for Live Operation, and Plug-in Compatibility for Easy Expansion.



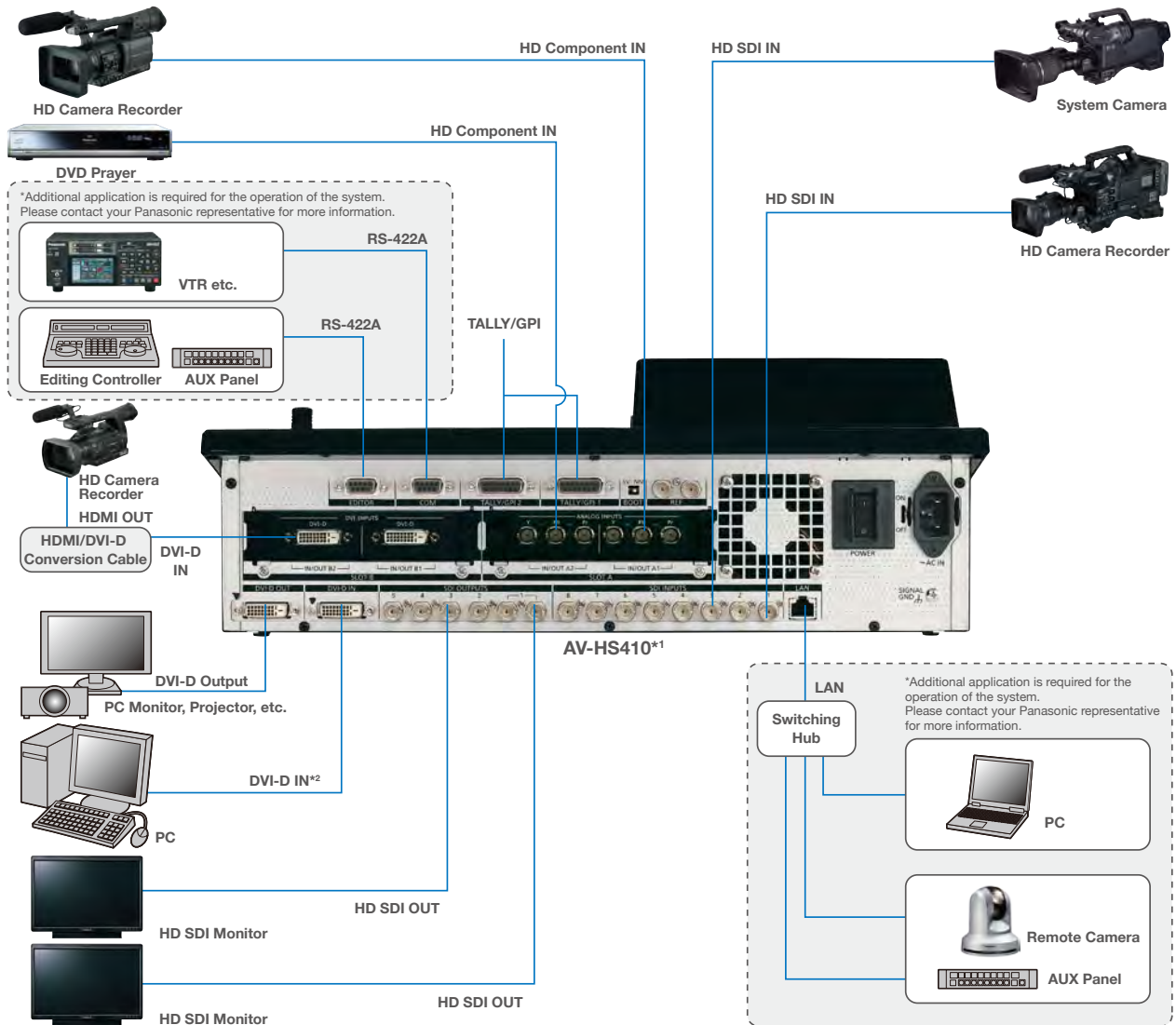
picture simulated

- **Nine Standard Inputs:** Eight SDI and One DVI
Six Standard Outputs: Five SDI and One DVI
Optional: Additional Four inputs/Four outputs maximum
- **Built-in 178 mm (7 inches) multi-mode color LCD monitor** displays versatile menus, image monitor, waveform/vectorscope, etc.
- **Featuring High-quality Primatte® chroma keying and Versatile transitions,** including DVE functions
- **Enhanced MultiViewer Display** with up to 16 splits enables nine screen variations, clock, level meter and 4:3 marker display.
- **Video Memory function** allows playback of two channels of still or moving images.
- **Memory Preview function** provides previews of shot memory and event memory image effects.
- **Supports Plug-in API function** for external control, external camera control, output of status data, etc.
- **Control panel** with additional direct button control, numeric keypad, etc achieves enhanced ease of operation.

* Primatte® is a registered trademark of IMAGICA DIGIX Inc. The copyrights of Primatte® belong to IMAGICA DIGIX Inc. The patents for Primatte® belong to IMAGICA DIGIX Inc.

Power Requirement:	AC 100 V to 240 V, 50 Hz/60 Hz, 88 W
Operating Temperature:	0 °C to 40 °C (32 °F to 104 °F)
Operating Humidity:	10 % to 90 % (no condensation)
Dimensions: (W x H x D)	440 mm x 158 mm x 361 mm (17-5/16 inches x 6-7/32 inches x 14-7/32 inches) excluding protrusions
Weight:	Approx. 6.2 kg (13.669 lb) excluding accessory parts when no options have been installed Approx. 6.6 kg (14.550 lb) excluding accessory parts when all the possible options have been installed
Video Inputs (13 signal lines maximum):	Standard SDI: 8 signal lines, BNC x 8 (SDI INPUT 1 to SDI INPUT 8) (The up-converter function can be used for the SDI INPUT 5 to SDI INPUT 8 connectors.) Standard DVI-D: 1 signal line, DVI-D x 1 Optional: Up to 4 additional signal lines (IN A1, IN A2, IN B1, IN B2) (Up to two option boards can be installed in the two input/output slots.)
Video Outputs (10 signal lines, maximum):	Standard SDI: 5 signal lines, BNC x 6 (SDI OUTPUT 1 to SDI OUTPUT 5 x 1 line each, 2 distributed outputs for SDI OUTPUT 1 only) Standard DVI-D: 1 signal line, DVI-D x 1 Optional: Up to 4 additional lines (OUT A1, OUT A2, OUT B1, OUT B2) • PGM, PVW, AUX1 to AUX4, MV (MULTI_VIEW), CLN, KEYOUT and MEM PVW can be assigned to SDI OUTPUT 1 to SDI OUTPUT 5, DVI-D OUT, OUT A1, OUT A2, OUT B1 and OUT B2. • CLN can be pre-selected from KEY or DSK using a menu. (Up to two option boards can be installed in the two input/output slots.)
Signal Formats:	SD: 480/59.94i, 576/50i HD: 1080/59.94i, 1080/50i, 720/59.94p, 720/50p, 1080/24PsF*, 1080/23.98PsF* *The following option boards are not supported: AV-HS04M1, AV-HS04M2, AV-HS04M3, AV-HS04M4, AV-HS04M5, AV-HS04M6, AV-HS04M7
Signal Processing:	Y: Pb: Pr 4: 2: 2, 10 bit (8 bit for video memory), RGB 4:4:4, 8 bit
ME Number:	1 ME
SDI Inputs:	HD-SDI: HD Serial digital (SMPTE 292M) SD-SDI: SD Serial digital (SMPTE 259M) 8 signal lines, standard: IN1 to IN8 12 signal lines, maximum: IN A1, IN A2, IN B1, IN B2 (When two AV-HS04M1 boards are used; with active through) HD: SMPTE 292M (BTA S-004B) standard complied with • 0.8 V [p-p] ±10 % (75 Ω) • Automatic equalizer More than 100 m (328 ft) (when 1.5 Gbps/5C-FB cable is used) SD: SMPTE 259M standard complied with • 0.8 V [p-p] ±10 % (75 Ω) • Automatic equalizer 200 m (656 ft) (when 5C-2V cable is used)
SDI Outputs:	HD-SDI: HD Serial digital (SMPTE 292M) SD-SDI: SD Serial digital (SMPTE 259M) 5 signal lines, standard: OUT1 x 2; OUT2 to OUT5 x 1 each 9 signal lines, maximum: OUT A1, OUT A2, OUT B1, OUT B2 (When two AV-HS04M7 boards are used) HD: SMPTE 292M (BTA S-004B) standard complied with • Output level 0.8 V [p-p] ± 10 % • Rise time HD: Less than 270 ps • Fall time HD: Less than 270 ps • Difference between rise time and fall time HD: Less than 100 ps • Alignment jitter HD: Less than 0.2 UI (130 ps) • Timing jitter HD: Less than 1.0 UI • Eye aperture ratio More than 90 % • DC offset 0 ±0.5 V SD: SMPTE 259M standard complied with • Output level 0.8 V [p-p] ±10 % • Rise time Less than 1.5 ns • Fall time Less than 1.5 ns • Difference between rise time and fall time Less than 0.5 ns • Jitter Less than 0.2 UI
Composite Input: (Option board)	Analog composite signal (NTSC/PAL) (1.0 V [p-p], 75 Ω) 4 signal lines, maximum: IN A1, IN A2, IN B1, IN B2 (When two AV-HS04M6 boards are used; with loop-through)
Analog Input: (Option board)	SD/HD analog component Y/Pb/Pr (1.0 V [p-p], 75 Ω) 4 signal lines, maximum: IN A1, IN A2, IN B1, IN B2 (When two AV-HS04M2 boards are used)
Analog Output: (Option board)	SD/HD analog component Y/Pb/Pr (1.0 V [p-p], 75 Ω) 4 signal lines, maximum: OUT A1, OUT A2, OUT B1, OUT B2 (When two AV-HS04M4 boards are used) • 2 signal lines (OUT A1, OUT B1) when two AV-HS04M5 boards are used.
DVI-I Input: (Option board)	Analog/digital RGB: XGA (1024 x 768), WXGA (1280 x 768), SXGA (1280 x 1024) Vertical frequency: 60 Hz • This connector does not support the HDCP technologies. 4 signal lines, maximum: IN A1, IN A2, IN B1, IN B2 (When two AV-HS04M3 boards are used)

DVI-I Output: (Option board)	Analog/digital RGB: XGA (1024 x 768), WXGA (1280 x 768), SXGA (1280 x 1024), WSXGA+* (1680 x 1050), UXGA* (1600 x 1200), WUXGA* (1920 x 1200) * Selectable only when digital signals are output. Vertical frequency: 60 Hz • This connector does not support the HDCP technologies. 2 signal lines, maximum: OUT A2, OUT B2 (When two AV-HS04M5 boards are used)
DVI-D Input: (Option board)	Digital RGB: XGA (1024 x 768), WXGA (1280 x 768), SXGA (1280 x 1024), WSXGA+ (1680 x 1050), UXGA (1600 x 1200), WUXGA (1920 x 1200) Vertical frequency: 60 Hz Digital RGB: 1080/50p, 1080/59.94p • Analog input signals are not supported. • This connector does not support the HDCP technologies. 4 signal lines, maximum: IN A1, IN A2, IN B1, IN B2 (When two AV-HS04M8 boards are used) • The DVI-I connector cable cannot be used. • For the DVI-D connector cable, use a cable with a length of up to 5 m (16.4 ft).
DVI-D Input/Output:	Digital RGB: XGA (1024 x 768), WXGA (1280 x 768), SXGA (1280 x 1024), WSXGA+ (1680 x 1050), UXGA (1600 x 1200), WUXGA (1920 x 1200) Vertical frequency: 60 Hz Video format inputs: Digital RGB: 1080/50p, 1080/59.94p Vertical frequency: Same as system formats Video format outputs: Digital RGB: 1080/50p, 1080/59.94p, 1080/50i, 1080/59.94i, 720/50p, 720/59.94p • The input and output of analog signals are not supported. • Output support the high-resolution multi view mode: Signals are output with a high resolution even when SD is set as the system mode. (When high-resolution multi view mode has been enabled, MV is selected as the DVI-D OUT output, and it is not possible to select MV with SDI OUT.) • This connector does not support the HDCP technologies. Standard input/output: 1 line each (DVI-D IN, DVI-D OUT) • The DVI-I connector cable cannot be used. • For the DVI-D connector cable, use a cable with a length of up to 5 m (16.4 ft).
Reference Input/Output:	In GENLOCK mode: Black burst or Tri-level Sync input signals (with loop-through) In internal sync mode: Black burst output signals x 2 • Same field frequencies as those of the system formats supported. • With the 1080/24PsF format, only GENLOCK mode supported. • With the 1080/23.98PsF format, black burst with 10F-ID (SMPTE318M standard met) or TRI signals supported.
Video Delay Time:	1 line (H), When the frame synchronizer setting is "Off" and the up-converter setting is "Off". 1 frame (F), When the frame synchronizer setting is "On" or the up-converter setting is "On". • When the signals have passed through PinP, DVE, multi view, down-converter, DVI-IN or DVI-OUT, a maximum delay of 1 frame is applied in each case.
Control I/O (LAN):	RJ-45 LAN 10BASE-T/100BASE-TX (For IP control) Connecting cable: LAN cable (category 5 or above), max. 100 m [328 ft], STP (Shielded Twisted Pair) cable recommended • When connecting to a hub (switching hub), use a straight cable. Use a crossover cable when connecting the unit and computer on a 1:1 basis without going through a hub. • Use with the same segment is recommended for the equipment which is connected to the unit. If the unit is connected to equipment whose segments are different, events dependent upon the settings inherent to the network equipment, for instance, may occur so thoroughly check the connections with the equipment to which the unit will be connected prior to the start of operation.
Control I/O (EDITOR):	D-sub, 9-pin, female EDITOR Used to control an editor RS-422 control connector Communication format Baud rate: 38400 bps, Character length: 8 bit, Parity: Odd Stop bit: 1 bit, Flow control: None
Control I/O (COM):	D-sub, 9-pin, female COM Used to control an external device RS-422 control connector Communication format (selected using a menu) • Mode: 1 (default setting), Baud rate: 9600 bps, Character length: 8 bit Parity: None, Stop bit: 1 bit, Flow control: None • Mode: 2, Baud rate: 38400 bps, Character length: 8 bit, Parity: Odd Stop bit: 1 bit, Flow control: None • Mode: 3, Baud rate: 38400 bps, Character length: 8 bit, Parity: None Stop bit: 1 bit, Flow control: None
Control I/O: (TALLY/GPI 1 TALLY/GPI 2)	D-sub, 15-pin, female (x 2) Input: 8 inputs, general-purpose, photocoupler sensing Output: 19 outputs; selected from R/G tally, general-purpose Alarm: 1 output, open collector output (negative logic)
Other:	BOOT switch [SV/NM (service/normal)] (for maintenance purposes) Normally, this switch is used as the "NM" position.



*1: The photo shows a system example with the optional AV-HS04M8 and AV-HS04M2 boards mounted.
 *2: This connector does not support the HDCP technologies.

Nine Standard Inputs/ Six Standard Outputs (Max. 13 Inputs/10 Outputs)

The AV-HS410 comes standard with Nine inputs (Eight SDI (HD/SD) and One DVI-D) and Six outputs (Five SDI (HD/SD) and One DVI-D). Two expansion slots accommodate either input or output optional boards, providing a maximum of 13 inputs, and 10 outputs.

HD/SD Multi-Format Support

The AV-HS410 supports standard HD/SD multi-format, including 1080/24PsF. System frequency is 59.94 Hz/50 Hz/24 Hz switchable. This makes the system ideal for digital cinema production and worldwide operation. A wide range of optional boards also allows the input and output of analog component and various other signals. (Please see the table at the right for more details.)

Input/Output Signal		Standard				Option Board							
						AV-HS 04M1	AV-HS 04M2	AV-HS 04M3	AV-HS 04M4	AV-HS 04M5	AV-HS 04M6	AV-HS 04M7	AV-HS 04M8
Video Signal	Video Format	SDI x 8 IN	DVI-D x 1 IN	SDI x 5 OUT	DVI-D x 1 OUT	SDI x 2 IN	COMP x 2 IN	DVI-I x 2 IN	COMP x 2 OUT	DVI-I/COMP x 2 OUT	VIDEO x 2 IN	SDI x 2 OUT	DVI-D x 2 IN
SDI	480/59.94i	✓		✓		✓							✓
	576/50i	✓		✓		✓							✓
	1080/59.94i	✓		✓		✓							✓
	1080/50i	✓		✓		✓							✓
	720/59.94p	✓		✓		✓							✓
	720/50p	✓		✓		✓							✓
	1080/24PsF	✓		✓									
1080/23.98PsF	✓		✓										
DVI Analog	XGA (1024 x 768) 60 Hz/50 Hz							✓		✓			
	WXGA (1280 x 768) 60 Hz/50 Hz							✓		✓			
	SXGA (1280 x 1024) 60 Hz/50 Hz							✓		✓			
DVI Digital (PC)	XGA (1024 x 768) 60 Hz/50 Hz		✓		✓			✓		✓			✓
	WXGA (1280 x 768) 60 Hz/50 Hz		✓		✓			✓		✓			✓
	SXGA (1280 x 1024) 60 Hz/50 Hz		✓		✓			✓		✓			✓
	UXGA (1600 x 1200) 60 Hz/50 Hz		✓		✓					✓			✓
	WSXGA+ (1680 x 1050) 60 Hz/50 Hz		✓		✓					✓			✓
WUXGA (1920 x 1200) 60 Hz/50 Hz		✓		✓					✓			✓	
DVI Digital (VIDEO)	1080/59.94i		✓		✓								✓
	1080/59.94p		✓		✓								✓
	1080/50i		✓		✓								✓
	1080/50p		✓		✓								✓
	720/59.94p		✓		✓								✓
720/50p		✓		✓								✓	
Analog Composite	NTSC											✓	
	PAL											✓	
Analog Component	480/59.94i							✓		✓	✓		
	576/50i							✓		✓	✓		
	1080/59.94i							✓		✓	✓		
	1080/50i							✓		✓	✓		
	720/59.94p							✓		✓	✓		
720/50p							✓		✓	✓			

Various Switching Functions and High Image Quality are Achieved with an Intuitive User Interface.

Built-in Frame Synchronizer for All Input Channels

All input channels feature a built-in frame synchronizer for use in switching unsynchronized video signals. A gen-lock function also supports synchronizing systems based on external sync signals (black burst or tri-level).

Up-Converter, Dot by Dot and Video Processing

The AV-HS410 is equipped with an SD/HD up-converter function for four inputs, and a dot by dot function for eight inputs. Dot by dot input can be used for P-in-P display of HD images from SD footage without degradation. A video processing function with color correction is also provided for eight inputs.

Four Aux Buses and Two P-in-P

Two P-in-P buses and four Aux buses are provided. Borders and software effects can be applied to the P-in-P buses. In addition to a Cut transition, the bus transition function (P-in-P bus and Aux bus switching effect) also enables a Mix transition (Aux 1 only). Flexible operation is achieved by combining Aux buses and M/E sections.

Versatile Transitions and Effects

In addition to standard wipe, mix and cut effects, DVE transition patterns using two channels, such as reduce, slide, squeeze and 3D wipe are included.



Circle wipe



Page turn

New Video Memory Function for Two Inputs

Two inputs for still (STILL) or moving (CLIP) images can be saved in Video Memory, and selected as bus footage. Moving pictures can be recorded and played with key signals (for a maximum of approximately 20 seconds/600 frames with 59.94i). Moving picture and still files can also be transferred over a LAN network from an SDHC/SD Memory Card or PC.

* Uploading of moving picture and still images from an Ethernet LAN will be supported in the future.

SDHC/SD Memory Card Slot

Video memory, shot memory, event memory and set-up data can be saved to SDHC/SD Memory Cards.

Primatte® High-Quality Chroma Key

Linear, luminance and chroma keying are provided. Chroma keying employs the Primatte® algorithm, which is widely used as a plug-in for nonlinear editors. The same excellent Primatte® image quality that is used worldwide for movies, TV programs, music videos and commercials is achieved by the AV-HS410's real time processing. Superior blue-spill processing naturally combines translucent objects, such as thin cloth and glass, with background colors. Extremely fine objects, such as individual strands of hair, are faithfully reproduced. One DSK channel is also provided to add borders, shadows, and other edge effects.



Primatte® chroma key (picture simulated)



Conventional chroma key (picture simulated)

* Primatte® is a registered trademark of IMAGICA DIGIX Inc. The copyrights of Primatte® belong to IMAGICA DIGIX Inc. The patents for Primatte® belong to IMAGICA DIGIX Inc.

Shot Memory

Up to 100 image effects, such as background transition patterns, P-in-P sizes and border widths, can be registered in shot memory for instant retrieval. The AV-HS410's Effect Dissolve function enables smooth switching from a current image to one of the images or operations registered in the shot memory.

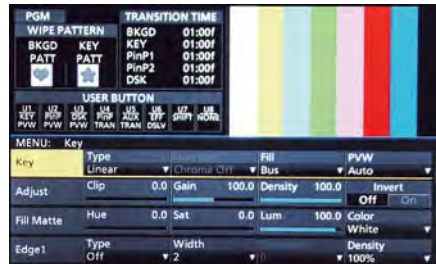
Event Memory

Up to 64 of the image effects that are registered in the shot memory can be sequentially registered in the event memory for instant retrieval. This allows highly expressive consecutive effects to be easily and smoothly executed. Up to 100 event memories can be registered.





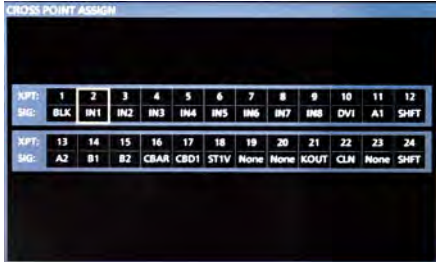
Menu display in Matrix type



Menu display/Subscreen/Image display



One line of menu display on a image monitor



Assign of cross point



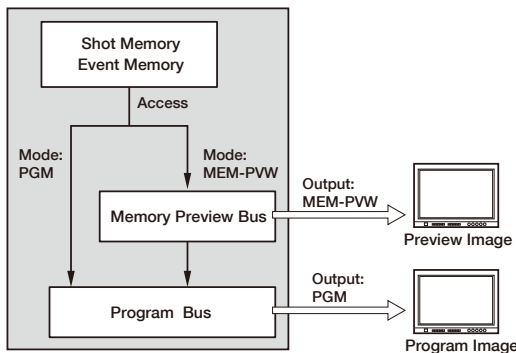
WFM display



VECTOR display

New Memory Preview

This new function lets you preview the shot memory and event memory content. It allows image effects to be easily confirmed while on-air with this 1 M/E switcher. This is particularly convenient for live operation.



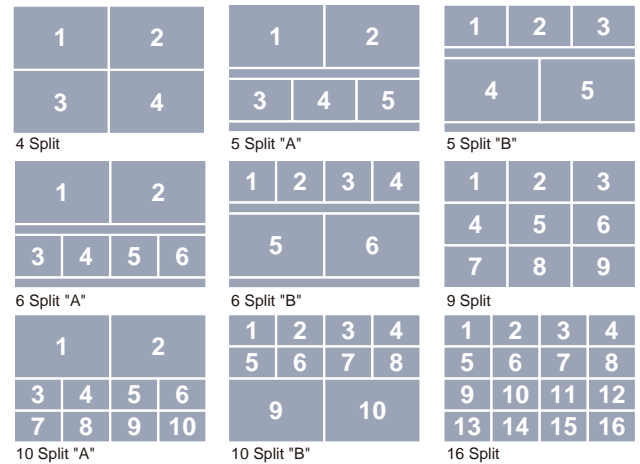
* The resolution of images output from memory is slightly lower than the usual resolution.

Built-in 178 mm (7 inches) Color LCD Monitor with Multi-Mode Display

A 178 mm (7 inches) color LCD monitor with WVGA (800 x 480) resolution is built into the control panel. It can be switched to a wide variety of display modes, including setting menus, image monitoring and waveform/vectorscope. (See the table above.) It also supports the MultiViewer and Memory Preview functions. AV-HS410 provides comfortable operation eliminating the need to view multiple displays in different locations.

Enhanced MultiViewer Display

The MultiViewer function lets you split the screen to display P/W, PGM and all source images on a single screen. It enables 4/5/6/9/10/16 split screens. The input signal name, audio level meter and 4:3 marker can also be overlaid onto each screen, and a clock can be displayed. This makes it possible to efficiently operate a multi-channel system with a single monitor.



Easy-to-Use Panel Layout

Features such as a total of 12 crosspoint buttons in each A bus and B bus (for a maximum of 22 with the Shift function) allow direct control with this simple panel layout. Function settings and registrations are made quickly and intuitively with the LCD monitor's matrix menu and rotary switches. Various functions can also be assigned to eight user buttons for one-touch operation. This level of easy operation supports speed and accuracy in live-relay operation.



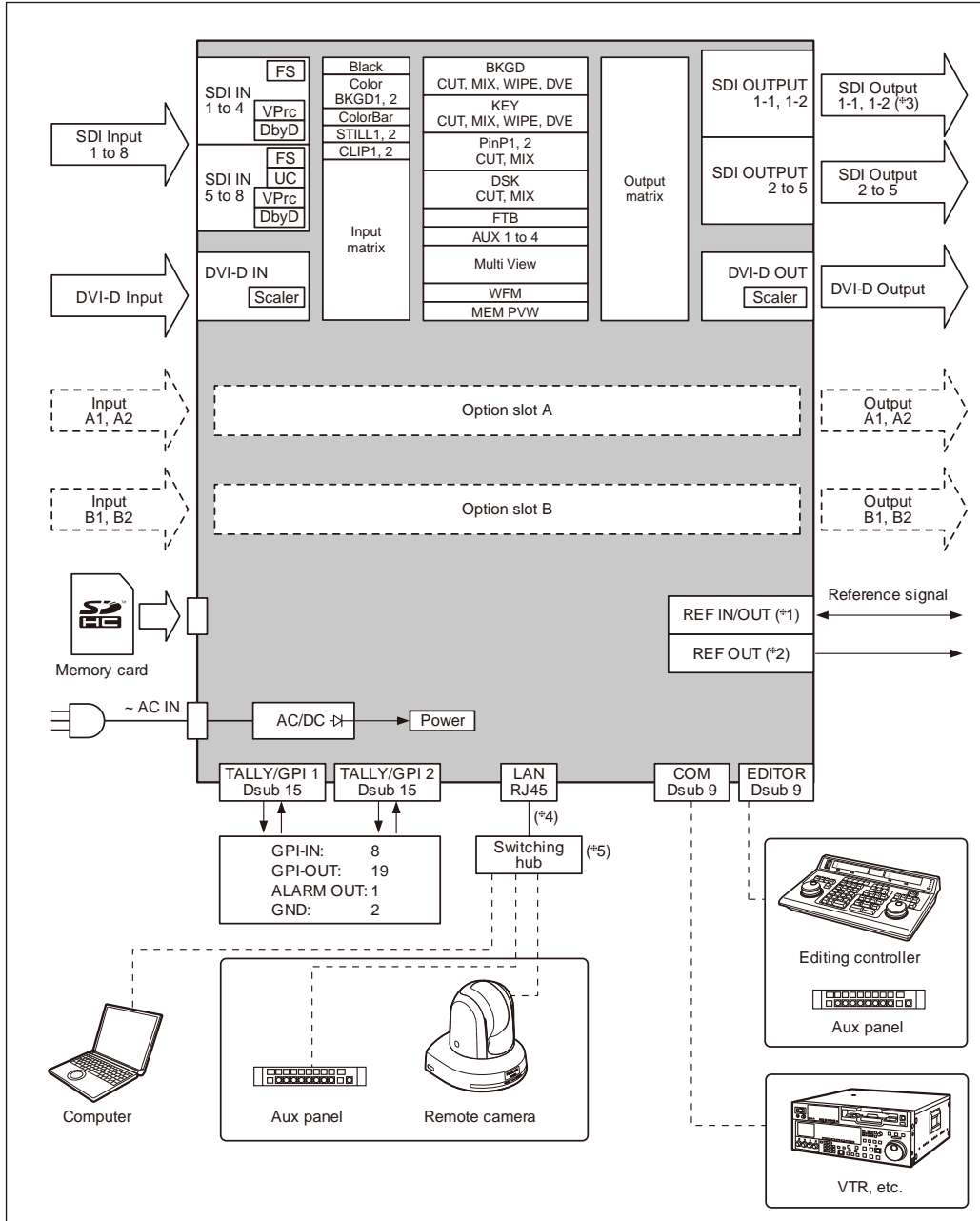
Expanded Functions with Plug-in Software and Optional Boards

Plug-in Software Created with a Software Development Kit*

Plug-ins allow flexible expansion of software-based functions. A Software Development Kit (SDK) is provided so that third parties or SI enterprises can freely develop the software to add new functions to the AV-HS410. This will enable the system to meet an even wider range of needs, such as controlling the AV-HS410 with an external controller or PC, operating cameras and other devices from the AV-HS410, and outputting status data related to the live switcher or image sources.

* Please ask your dealer for details.

Block Diagram



*1: When external synchronization is selected as the reference signal setting, the reference signal is input. When internal synchronization is selected, the reference signal is output.

*2: When external synchronization is selected as the reference signal setting, the signals are looped through output. When internal synchronization is selected, the reference signal is output.

*3: Two sets of the same output signals are distributed from SDI OUTPUT 1.

*4: Use a crossover cable when connecting the unit and another device on a 1:1 basis without going through a switching hub.

*5: Use a switching hub.

Input Option Boards

(As of December, 2011)



AV-HS04M1
SDI Input Board
SDI (HD/SD) x 2 (BNC)
(Built-in Up-converter)



AV-HS04M2
Analog Component Input Board
HD/SD Analog Component x 2 (Y/Pb/Pr)
(Built-in Up-converter)



AV-HS04M3
DVI Input Board
DVI-I x 2 (Built-in Scaler)



AV-HS04M6
Analog Composite Input Board
Analog Composite x 2 (Built-in Up-converter)



AV-HS04M8
Full HD DVI Input Board
DVI-D x 2 (compatible with WUXGA)

Output Option Boards

(As of December, 2011)



AV-HS04M4
Analog Output Board
HD/SD Analog Component x 2 (Y/Pb/Pr)

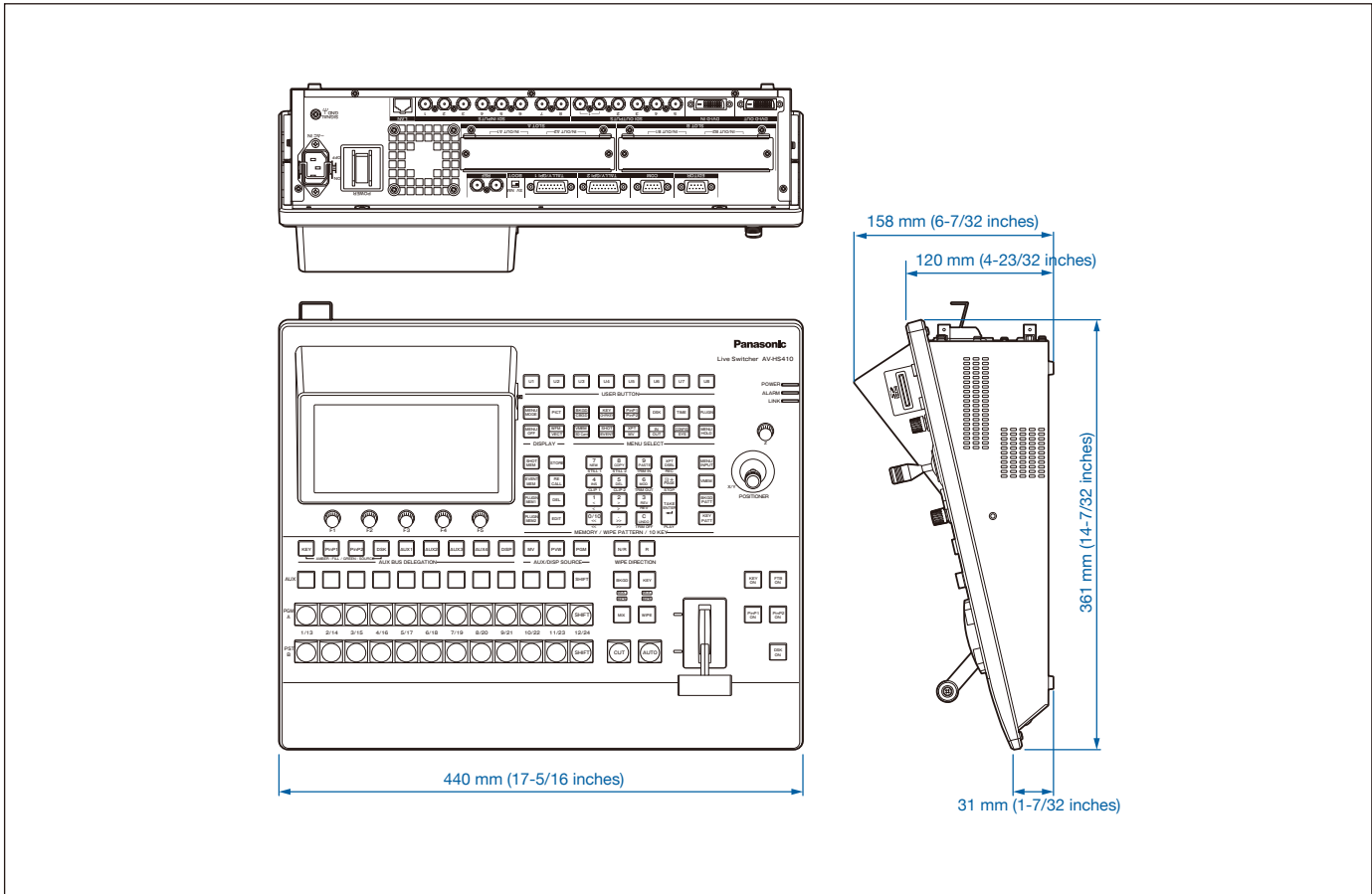


AV-HS04M5
DVI/Analog Output Board
DVI-I x 1, HD/SD Analog Component x 1
(Y/Pb/Pr)



AV-HS04M7
SDI Output Board
SDI (HD/SD) x 2 (Each one has 2 outputs)
(BNC) (Built-in Down-converter)

Dimensions



Please refer to the latest information, etc. at the following Panasonic web site.



<http://pro-av.panasonic.net/>

Panasonic®

Panasonic Corporation
Business Solutions Business Group
 2-15 Matsuba-cho, Kadoma, Osaka 571-8503
 Japan
<http://pro-av.panasonic.net/>

[Countries and Regions]

Argentina	+54 1 308 1610	Kuwait	+96 522431385
Australia	+61 (0) 2 9491 7400	Lebanon	+96 11665557
Bahrain	+973 252292	Malaysia	+60 3 7809 7888
Belgium	+32 (0) 2 481 04 57	Mexico	+52 55 5488 1000
Brazil	+55 11 3889 4035	Netherlands	+31 73 64 02 577
Canada	+1 905 624 5010	New Zealand	+64 9 272 0100
China	+86 10 6515 8828	Norway	+47 67 91 78 00
Hong Kong	+852 2313 0888	Pakistan	+92 5370320 (SNT)
Czech Republic	+420 236 032 552/511	Palestine	+972 2 2988750
Denmark	+45 43 20 08 57	Panama	+507 229 2955
Egypt	+20 2 23938151	Peru	+51 1 614 0000
Finland, Latvia, Lithuania, Estonia	+358 (9) 521 52 53	Philippines	+63 2 633 6163
France	+33 (0) 1 47 91 64 00	Poland	+48 (22) 338 1100
Germany, Austria, Switzerland	+49 (0) 611 235 459	Portugal	+351 21 425 77 04
Greece	+30 210 96 92 300	Puerto Rico	+1 787 750 4300
Hungary	+36 (1) 382 60 60	Romania	+40 21 211 4855
India	+91 120 247 1000	Russia & CIS	+7 495 6654205
Indonesia	+62 21 385 9449	Saudi Arabia	+96 626444072
Iran		Singapore	+65 6270 0110
(Vida)	+98 21 2271463	Slovak Republic	+421 (0) 2 52 92 14 23
(Panasonic Office)	+98 2188791102	Slovenia, Albania, Bulgaria, Serbia,	
Italy	+39 02 6788 367	Croatia, Bosnia, Macedonia, Montenegro	
Jordan	+962 6 5859801		+36 (1) 382 60 60
Kazakhstan	+7 727 298 0891	South Africa	+27 11 3131622
Korea	+82 2 2106 6641	Spain	+34 (93) 425 93 00
		Sweden	+46 (8) 680 26 41
		Syria	+963 11 2318422/4

Taiwan	+886 2 2227 6214
Thailand	+66 2 731 8888
Turkey	+90 216 578 3700
U.A.E. (for All Middle East)	+971 4 8862142
Ukraine	+380 44 4903437
U.K.	+44(0)1344 70 69 13
U.S.A.	+1 877 803 8492
Vietnam	+848 38370280



JQA-0443



Factories of Business Solutions Business Group have received ISO14001:2004-the Environmental Management System certification. (Except for 3rd party's peripherals.)

Capture HD™ High-Definition Capture Recorder

- > Delivers a low-cost, high-performance HD presentation capture solution
- > Designed for college, university, teaching hospital, government, and business applications
- > Records the complete AV presentation, classroom lecture, or training session
- > Captures in high-quality H.264 format at up to HD 1080p resolution
- > Allows live streaming to any device or server via RTSP (Real Time Streaming Protocol)
- > Extremely easy to use and flexible enough to fit any workflow model
- > Works with Crestron® Fusion RV™ software for a total workflow engine^[1]
- > Integrates easily into existing AV presentation systems and networks
- > Provides inputs for high-definition digital and analog AV sources
- > Built-in scaling ensures compatibility with a full range of sources
- > Provides a composite video input for the presenter's camera
- > CAPTURE-HD-PRO model includes high-definition 3G-SDI camera input
- > Includes local AV output for confidence monitoring or presentation pass-thru
- > Allows Crestron control system integration via Ethernet
- > Gigabit Ethernet enables high transfer rates for uploading of HD media files
- > Easy out-of-the-box setup
- > Single-space 19" rack-mountable



stream live video to a touch screen, computer, mobile device, or third-party streaming server. Schools and businesses may easily implement a facility-wide media capture solution by equipping every room with CAPTURE-HD recorders, all centrally managed by Crestron Fusion RV™ Remote Asset Management Software^[1].

A Closer Look at the Box

The CAPTURE-HD recorder is a compact unit, designed to sit on a shelf or mount in an equipment rack or podium. It captures presentation content from a computer or other source along with a live camera image and records them together in full-motion HD. The two images may be composited on screen side-by-side or picture-in-picture (PIP). The camera PIP window can be sized and positioned in any corner of the screen over the presentation content. Either image may be captured full screen as well.

Audio content from the presentation source is captured in stereo along with the live “speech” signal from a wireless microphone. The two signals are mixed together and recorded as one high-quality stereo signal.

Additional Features:

- **Front Panel** — Intuitive controls are provided on the front panel for starting, pausing, and stopping a recording. Each button lights up in a different color to provide clear indication of recording status. An LED bargraph meter provides indication of the speech signal level so you’ll know that you’re being picked up loud and clear. A full-color LCD screen displays additional feedback and provides access to setup functions.
- **Content Inputs** — Connecting a computer, DVD player, or other presentation source is enabled via HDMI® and RGBHV inputs on the rear panel. The HDMI input handles high-definition digital AV devices and computers with stereo audio. The RGBHV input handles analog computer sources. Built-in scaling ensures compatibility with a full range of signals. A stereo analog audio input is also provided.
- **Camera Input** — A composite video input provides for the connection of a single camera. Crestron offers two cameras ideally suited for the application, the CAM-IFB-100 and CAM-IPTZ-100^[2]. A 3G-SDI input (CAPTURE-HD-PRO model only) is also offered, allowing for the use of a high-definition camera with SDI, HD-SDI, or 3G-SDI output.
- **Speech Input** — A wireless microphone or mic mixer can be connected for pickup of the presenter and other individuals speaking. Crestron

The CaptureLiveHD™ system from Crestron® answers the call for a high-quality meeting and lecture capture solution that’s simple enough for the entire faculty to use, and affordable enough for wide-scale deployment across any sized campus or corporate enterprise. CaptureLiveHD delivers a complete end-to-end solution for scheduling, recording, and online delivery of captured content at the lowest cost of ownership on the market. Flexible enough to fit any education, government, medical or corporate work-flow model, CaptureLiveHD translates to greater usage of resources and a more effective education experience while minimizing support overhead.

As part of a complete CaptureLiveHD system, the Capture HD High-Definition Capture Recorder (CAPTURE-HD) provides a very simple, one-box component for capturing lectures, AV presentations, medical procedures, seminars, and training sessions. It is designed for easy integration in a classroom, lecture hall, training lab, or boardroom. It allows presenters and instructors to use their choice of multimedia sources, including high-definition videos, computers, whiteboards, and annotators. The CAPTURE-HD base model provides HDMI® and RGBHV inputs for such sources, plus a composite video input for a camera and line-level audio input for a wireless mic. The CAPTURE-HD-PRO model adds a 3G-SDI input to support HD digital cameras.

Without requiring any special training or extra effort from the presenter, the CAPTURE-HD records the complete presentation in full-motion HD 1080p or 720p and uploads it to a network server for publishing. It can also

CAPTURE-HD Capture HD™ High-Definition Capture Recorder



CAPTURE-HD – Rear View



CAPTURE-HD-PRO – Rear View

FreeSpeech® wireless microphones ([MP-FS100_PAK](#) or [MP-FS200_PAK](#)^[2]) offer an ideal speech pickup solution.

- **Local Output** — HDMI and analog audio outputs are included for connection to a confidence monitor or AV system. These outputs may be used to view and hear exactly what is being recorded, or to pass the selected content source through for local presentation.
- **File Storage** — Captured AV files are stored locally on a MMC or USB storage device prior to uploading to the network. An MMC-compatible memory card slot and USB port are provided on the rear panel, and a 16GB MMC is included. An additional USB port is provided on the front panel, allowing recordings to be saved directly to a USB flash drive.
- **Live Streaming** — As an alternative to capturing video, the CAPTURE-HD can also be used to stream live HD video and audio via RTSP to a computer, mobile device, touch screen, or third-party streaming server.
- **Gigabit Ethernet** — Connection to the LAN is via 10/100/1000Base-T Ethernet, affording the highest possible transfer rate for uploading HD media files to your network server or streaming live video.

Touch Screen Remote

Adding the optional touch screen controller ([CAPTURE-TPMC-4SM](#)^[2]) enables simplified operation of the CAPTURE-HD from a lectern, desk, or wall mount location in the room. The presenter need only follow the prompts on the touch screen to easily start and stop a recording, pause or mute the recording and even add bookmarks during the session. The touch screen can also display a live view of the room camera and a microphone level meter to lend an extra level of confidence during operation.

Control System Integration

The CAPTURE-HD integrates seamlessly with a Crestron control system to enable expanded control over AV and room devices using a variety of touch screens, wireless remotes, computers, and mobile devices.

SPECIFICATIONS

Capture & Streaming

Video Recording Formats: H.264 high profile @ 720p24, 720p30, 720p60, and 1080p24

Video Recording Bitrates: 2000 to 6000 kbps

Video Streaming Formats: H.264 high profile @ 720p10, 720p15, 720p30, 720p60, 1080p10, 1080p15, and 1080p30

Video Streaming Bitrates: 500 to 6000 kbps

Audio Format: AAC stereo

Container: MPEG-2 transport stream (.ts)

Streaming Protocol: RTSP (unicast)

Storage

Memory Card: Supports MMC compatible card, 16 GB included

USB Flash Drive: Supports USB flash drive

Network: Supports file transfer to network media server

Video

Scaling: VXP® video processing, 3D and 2D noise reduction, block artifact reduction, mosquito noise reduction, motion and edge adaptive deinterlacing, detail enhancement, adaptive contrast enhancement, adaptive de-banding, film cadence detection, picture-in-picture and side-by-side windowing

Input Signal Types (Content): HDMI®, DisplayPort Multimode^[3], DVI^[3], RGB

Input Signal Types (Camera): composite, 3G-SDI^[4]

Output Signal Types: HDMI, DVI^[3]

Input Formats: HDMI, DVI^[3], RGBHV up to UXGA/WUXGA, HDTV up to 1080p60, NTSC or PAL, SD-SDI (SMPTE 259M)^[4], HD-SDI (SMPTE 292M)^[4], 3G-SDI (SMPTE 424M)^[4]

Input Resolutions, HDMI, Progressive: Any resolution and frame rate from 640x400 to 1920x1200 up to 162 MHz pixel clock

Input Resolutions, HDMI, Interlaced: 480i, 576i, 1080i25 (1125 lines), 1080i30

Input Resolutions, RGB, Progressive: Any resolution and frame rate from 640x400 to 1920x1200 up to 162 MHz pixel clock

Input Resolutions, Composite: 480i, 576i

Input Resolutions, 3G-SDI^[4]:

SMPTE 425M (3G-SDI) 4:2:2 Colorspace: 1920x1080@50Hz (1080p50), 1920x1080@60Hz (1080p60);

SMPTE 425M (3G-SDI) 4:4:4 Colorspace: 1280x720@50Hz (720p50), 1280x720@60Hz (720p60), 1920x1080@24Hz (1080p24), 1920x1080@25Hz (1080p25), 1920x1080@30Hz (1080p30), 1920x1080@50Hz (1080i50 or 1080sF25), 1920x1080@60Hz (1080i60 or 1080sF30);

CAPTURE-HD Capture HD™ High-Definition Capture Recorder

SMPTE 260M (HD-SDI): 1920x1035@60Hz (1035i60);
SMPTE 295M (HD-SDI): 1920x1080@50Hz (1080i50);
SMPTE 274M (HD-SDI): 1920x1080@24Hz (1080p24),
1920x1080@24Hz (1080sF24), 1920x1080@25Hz (1080p25),
1920x1080@30Hz (1080p30), 1920x1080@50Hz (1080i50 or
1080sF25), 1920x1080@60Hz (1080i60 or 1080sF30);
SMPTE 296M (HD-SDI): 1280x720@50Hz (720p50), 1280x720@60Hz
(720p60);

SMPTE 259M-C (SD-SDI): 720x480@59.94 (NTSC), 720x576@50i (PAL)

Output Resolutions, HDMI: Same as CONTENT input (HDMI or RGBHV)
when viewing the selected content source, or same as capture settings
when viewing the capture image

A-D Conversion: 10-bit 162 MHz per each of 3 channels

Audio

Processing: Provides mixing of the stereo CONTENT audio signals with
the mono SPEECH signal

A-D/D-A Conversion: 24-bit 48 kHz

Input Signal Types: HDMI, DisplayPort Multimode^[3], analog stereo,
analog mono

Output Signal Types: HDMI, analog stereo

Formats, HDMI: 2ch PCM

Formats, Analog: Stereo 2-channel

Content Input Compensation: ±10.0 dB

Content Mix Level: -80.0 to 0.0 dB

Content Bass: ±15.0 dB

Content Treble: ±15.0 dB

Content Audio Delay: 0.0 to 40.0 ms

Speech Input Compensation: ±10.0 dB

Speech Mix Level: -80.0 to 0.0 dB

Speech Bass: ±15.0 dB

Speech Treble: ±15.0 dB

Output Volume^[5]: -80 to +20 dB, adjustable from 0% to 100%, plus mute

Output Bass^[5]: ±15.0 dB

Output Treble^[5]: ±15.0 dB

Performance (analog):

Frequency Response: 20Hz to 20kHz ±0.75dB typical;

S/N Ratio: >90dB, 20Hz to 20kHz A-weighted;

THD+N: <0.05% @ 1kHz;

Stereo Separation: >90dB

Communications

Ethernet: 10/100/1000 Mbps, auto-switching, auto-negotiating, auto-
discovery, full/half duplex, DHCP

USB: USB 2.0 host, supports USB flash drives and USB mass storage
devices

Connectors

SPEECH IN (Unbalanced): (1) RCA female;

Unbalanced line-level audio input;

Input Impedance: 10k Ohms nominal;

Input Level: 2 Vrms maximum

SPEECH IN (Balanced): (1) 3-pin 3.5mm detachable terminal block;

Balanced/unbalanced line-level audio input;

Input Impedance: 17.5k Ohms nominal balanced/unbalanced;

Balanced Input Level: 4 Vrms maximum;

Unbalanced Input Level: 2 Vrms maximum

CONTENT AUDIO IN (Unbalanced): (1) 3.5mm TRS mini phone jack;

Unbalanced stereo line-level audio input;

Input Impedance: 18.5k Ohms nominal;

Input Level: 1 Vrms maximum

CONTENT AUDIO IN (Balanced): (1) 5-pin 3.5mm detachable terminal
block;

Balanced/unbalanced stereo line-level audio input;

Input Impedance: 24k Ohms nominal balanced/unbalanced;

Balanced Input Level: 4 Vrms maximum;

Unbalanced Input Level: 2 Vrms maximum

AUDIO OUT L, R (Unbalanced): (2) RCA female;

Unbalanced stereo line-level audio output;

Output Impedance: 100 Ohms nominal;

Output Level: 2 Vrms maximum

AUDIO OUT (Balanced): (1) 5-pin 3.5mm detachable terminal block;

Balanced/unbalanced stereo line-level audio output;

Output Impedance: 200 Ohms balanced, 100 Ohms unbalanced;

Balanced Output Level: 4 Vrms maximum;

Unbalanced Output Level: 2 Vrms maximum

CAMERA IN, COMPOSITE: (1) BNC female analog composite video input;

RCA adapter included;

Input Impedance: 75 Ohms nominal;

Input Level: 1 Vp-p nominal

CAMERA IN, 3G-SDI^[4]: (1) BNC female, SDI video input;

Input Impedance: 75 Ohms nominal

CONTENT IN, RGBHV: (1) DB15HD female, RGB (VGA) input;

Formats: RGBHV, RGBS, RGSB;

Input Levels: 0.5 to 1.5 Vp-p with built-in DC restoration;

Input Impedance: 75 Ohms nominal;

Sync Detection: RGBHV, RGBS, RGSB;

Sync Input Level: 3 to 5 Vp-p;

Sync Input Impedance: 511 Ohms nominal

CONTENT IN, HDMI: (1) 19-pin Type A HDMI female;

HDMI digital video/audio input;

Also supports DVI and DisplayPort Multimode^[3]

LOOP OUT, RGBHV: (1) DB15HD female, buffered pass-thru from
RGBHV input

HDMI OUT: (1) 19-pin Type A HDMI female;

HDMI digital video/audio output;

Also supports DVI^[3]

MEMORY: (1) MMC compatible card slot;

Accepts Multimedia Memory Cards (MMC) for memory expansion

CAPTURE-HD Capture HD™ High-Definition Capture Recorder

USB: (2) USB Type A female (1 front, 1 rear);
USB 2.0 host ports for connection of a USB flash drive or mass storage device

LAN: (1) 8-wire RJ45, female;
10/100/1000BaseT Ethernet port

12VDC 5.0A: (1) 2.5mm barrel DC power jack;
12 Volt DC power input;
PW-1250DU power pack included

G: (1) 6-32 screw, chassis ground lug

COMPUTER (front): (1) USB Type B female, for future use

Display

Display Type: TFT active matrix color LCD
Size: 1.8 inch (46 mm) diagonal
Resolution: 220 x 176 pixels
Functions: Displays recording status, time counter, audio levels, setup parameters, and other details

Controls & Indicators

RESET: (1) recessed miniature pushbutton for hardware reset
Meter: (1) 10-segment LED bargraph, indicates Speech audio signal level
▲, ▼, ◀, ▶: (4) pushbuttons, for 4-way LCD menu navigation and parameter adjustment
SELECT: (1) pushbutton, used to select or execute the highlighted menu item or value
HOME: (1) pushbutton, returns to the home menu
BACK: (1) pushbutton, steps menu back one level
REC, PAUSE, STOP: (3) transport style buttons with translucent button caps and LED backlighting for feedback, used to control the capture function
LAN (rear): (2) green LEDs, indicate Ethernet link status, speed, and activity

Power Requirements

Power Pack: 5 Amps @ 12 Volts DC;
100-240 Volts AC, 50/60 Hz power pack, model PW-1250DU included

Environmental

Temperature: 32° to 104°F (0° to 40°C)
Humidity: 10% to 90% RH (non-condensing)
Heat Dissipation: 69 BTU/hr

Enclosure

Chassis: Metal with matte black finish, vented sides, variable-speed fan-cooled
Faceplate: Metal, matte black finish with polycarbonate label overlay
Mounting: Freestanding or 1U 19-inch rack-mountable (adhesive feet and rack ears included)

Dimensions

Height: 1.91 in (49 mm);
1.70 in (44 mm) without feet
Width: 17.03 in (433 mm);
19.00 in (483 mm) with ears
Depth: 9.25 in (235 mm)

Weight

CAPTURE-HD: 4.1 lb (1.9 kg)
CAPTURE-HD-PRO: 4.2 lb (1.9 kg)

MODELS & ACCESSORIES

Available Models

CAPTURE-HD: Capture HD™ High-Definition Capture Recorder
CAPTURE-HD-PRO: Capture HD™ High-Definition Capture Recorder w/3G-SDI

Included Accessories

PW-1250DU: Universal Power Pack for CAPTURE-HD (Quantity 1 included)

Available Accessories

SW-FUSION-RV: Fusion RV™ Remote Asset Management Software
CEN-FUSION-RVS-R320: Pre-configured Fusion RV™ Server System
CAPTURE-TPMC-4SM: Touch Screen Controller for CAPTURE-HD
CAM-IFB-100: Camera for CAPTURE-HD
CAM-IPTZ-100: PTZ Camera for CAPTURE HD
MP-FS100_PAK: FreeSpeech® Single-Channel Wireless Mic System
MP-FS200_PAK: FreeSpeech® Dual-Channel Wireless Mic System
CBL Series: Crestron® Certified Interface Cables

CAPTURE-HD Capture HD™ High-Definition Capture Recorder

Notes:

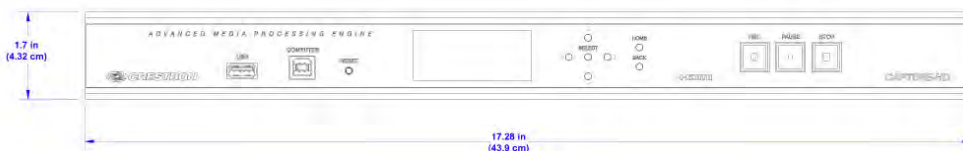
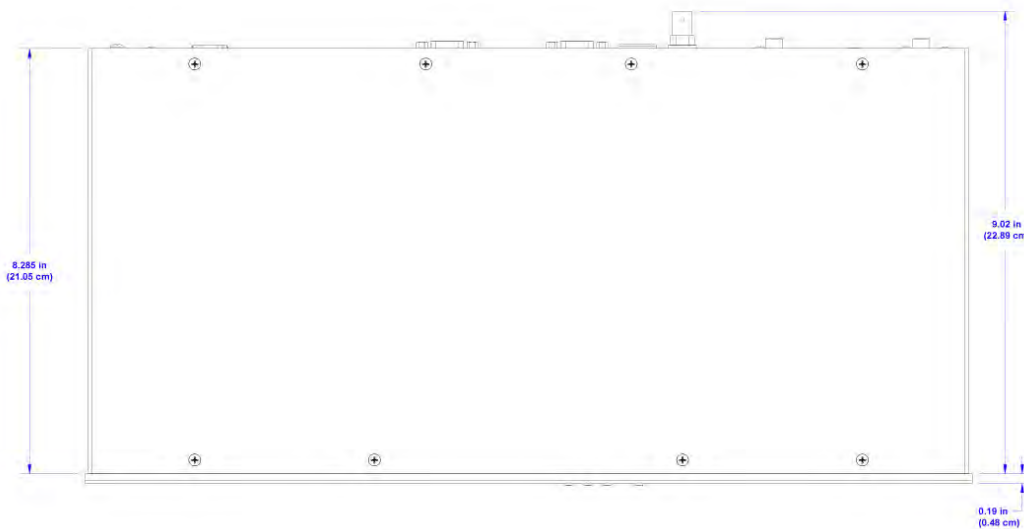
1. Fusion RV software and hardware server(s) sold separately. Refer to the Crestron CaptureLiveHD™ Design Guide, Doc. #4552 for complete system requirements and design guidelines.
2. Item(s) sold separately.
3. HDMI requires an appropriate adapter or interface cable to accommodate a DVI or DisplayPort Multimode signal. **CBL-HD-DVI** interface cables available separately.
4. SDI input capability is available on the CAPTURE-HD-PRO model only.
5. Affects analog audio outputs only.

This product may be purchased from an authorized Crestron dealer. To find a dealer, please contact the Crestron sales representative for your area. A list of sales representatives is available online at www.crestron.com/salesreps or by calling 800-237-2041.

Specifications subject to change without notice. Crestron is not responsible for errors in typography or photography.

The specific patents that cover Crestron products are listed online at: patents.crestron.com.

Capture HD, CaptureLiveHD, Crestron, FreeSpeech, Fusion RV, and the Crestron logo are either trademarks or registered trademarks of Crestron Electronics, Inc. in the United States and/or other countries. HDMI and the HDMI Logo are either trademarks or registered trademarks of HDMI Licensing LLC in the United States and/or other countries. VXP is either a trademark or registered trademark of Sigma Designs, Inc. and its subsidiaries in the United States and/or other countries. Other trademarks and trade names may be used in this document to refer to either the entities claiming the marks and names or their products. Crestron disclaims any proprietary interest in the marks and names of others. ©2012 Crestron Electronics, Inc.



Crestron DigitalMedia

Crestron DigitalMedia distributes uncompressed digital audio and video signals over a choice of shielded twisted pair copper wire or fiber optic cable. A full selection of switcher input cards, transmitters, and room controllers (receivers), provides extensive connectivity throughout the installation, supporting a complete range of analog and digital signal types. DigitalMedia intelligently manages all the different signals and devices, matching each source's output to the capabilities of the selected display(s) without scaling or compression. Every signal is preserved in its native video resolution and audio format, ensuring a pure, lossless signal path.

DigitalMedia handles more than just audio and video. Integrated Gigabit Ethernet, device control (IR, RS-232, CEC) and USB HID mouse and keyboard distribution allows computers, media servers, and video game consoles to be installed out of sight and accessed from anywhere in the installation. With no additional wiring, built-in Crestron control is also available for controlling displays and other room devices.

DigitalMedia:

- Distributes uncompressed digital audio and video over shielded twisted-pair wire (DM CAT or DM 8G® STP) or fiber
- Supports HDMI with Deep Color and 7.1 channel HD lossless audio
- Supports video resolutions up to 1920x1200 or 1080p/60
- Allows full 1080p/60 up to 330 ft without repeaters using standard CAT5e cable (or better)
- Supports 50/125 and 62.5/125 multimode fiber for distances up to 1,000 ft (300 m)

DigitalMedia Features

DigitalMedia transmits a wide variety of signals:

Audio	Video	Data
HDMI 7.1 Channel	HDMI	Ethernet
2, 6, or 8 channel PCM	Component (Y/Pb/Pr)	IR
DTS-HD Master Audio™	S-video	RS-232
Dolby® TrueHD	Composite	USB HID
S/PDIF	RGBHV	Crestron Control
2-Channel Analog	DisplayPort Multimode	
DisplayPort Multimode	HD-SDI	
	DVI	

DigitalMedia is installer-friendly, with a flexible choice of input and output cards. It expands easily to serve the most demanding multi-room solution. Advanced troubleshooting tools can be accessed via the front panel, Crestron Toolbox™ software, and control system to identify potential problems with HDCP keys and handshaking, CEC control, video resolutions, USB, wiring and audio format issues. DigitalMedia accommodates legacy AV systems, provides a zero-latency solution, and drives full HD content without compression or resolution loss.

Computer Compatibility

DigitalMedia handles every available HDTV format supported by HDMI and also supports the distribution of DVI and RGB computer signals. It is also fully compatible with DVI computer monitors up to 1920 x 1200 WUXGA.

USB HID Switch

DigitalMedia centralizes all HD sources – not just television receivers and DVD changers, but also media servers and computers. Built-in USB HID (Human Interface Device) signal routing allows USB HID compatible keyboards, and mice to be connected at each display location, extending their signals through to the centralized equipment via USB HID ports provided on select switcher input cards.

EDID Format Management

HDMI provides a variety of video and audio formats to keep track of, and chances are not every device in a system supports all of the same formats. In a typical one-room system, HDMI attempts to resolve this confusion using EDID. When two HDMI devices are connected together, the receiving device (a display or surround sound processor) uses EDID to announce its format capabilities to the source device (a TV tuner or video player), which in turn configures itself to output the most effective format that both devices can support.

However, serious conflicts can arise in a facility filled with different displays and audio systems. For instance, a Blu-ray player feeding a 1080p projector in the home theater may restrict itself to a lower resolution, or even shut off completely, if someone decides to view the same signal on the 32 in TV in the bedroom.

DigitalMedia uses EDID to prevent such conflicts, assessing the formats supported by each system device, and then allowing the installer to assign compatible devices in logical arrangements. Conflicting combinations can be prohibited so only the optimum signal formats get delivered to each display and audio system in the house.

QuickSwitch HD Technology

Many content providers are using the copy-protection scheme called HDCP to protect products against unauthorized copying. To view HDCP encrypted content in full high-definition requires the source device to “authenticate” every display and signal processor through an HDMI connection before delivering an output signal. This process occurs every time any HDMI signal is switched, causing a complete loss of signal for up to 15 seconds whenever a new source or display is selected anywhere in the house. Crestron QuickSwitch HD technology eliminates this issue by maintaining a constant HDCP connection with each HDMI device in the system. By eliminating the need to re-authenticate each time a different source or display is selected, QuickSwitch HD achieves very fast switching of HDMI signals.

HDCP Key Management

Another aspect to HDCP is its use of “keys” to manage the handshaking that occurs between any two devices. Every HDMI source device supports a limited number of downstream devices, as determined by the number of HDCP keys available. The number of HDCP keys is rarely advertised or specified by the manufacturer or service provider, so without warning, the source simply stops outputting a signal when connected to too many displays or processors. DigitalMedia handles all key management, providing fully encrypted data to any number of displays simultaneously.

CEC Signal Management

The primary objective of every Crestron system is to enable precisely the control desired for a seamless user experience. To ensure this outcome, DM switchers intercept the CEC signals that many HDMI devices automatically generate, preventing any unwanted commands from being executed – like a Blu-ray player attempting to turn off the video display when it gets turned off, or a DVD player trying to pause the other players in the system when it is playing. Through proper CEC management, DigitalMedia can control each device.

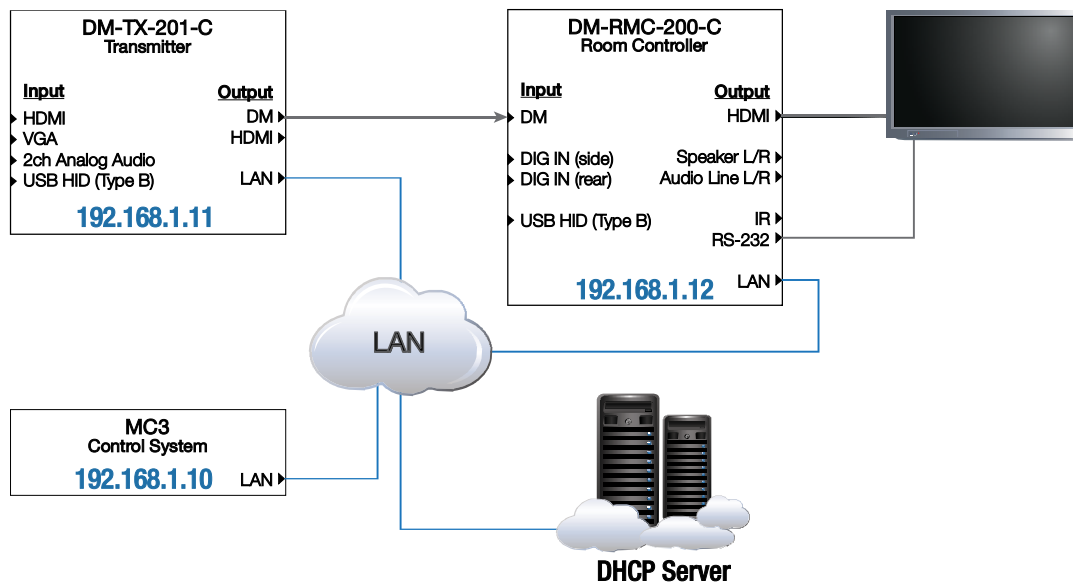
Ethernet Integration

DigitalMedia provides an Ethernet transport method in addition to HDMI, control, and USB HID transport. DigitalMedia carries 10/100 Ethernet to each room controller and transmitter, supporting streaming media for multimedia devices, or providing LAN connectivity for any room device that requires Ethernet or Internet access. Its Gigabit Ethernet connection to the external LAN helps maximize bandwidth for each network port.

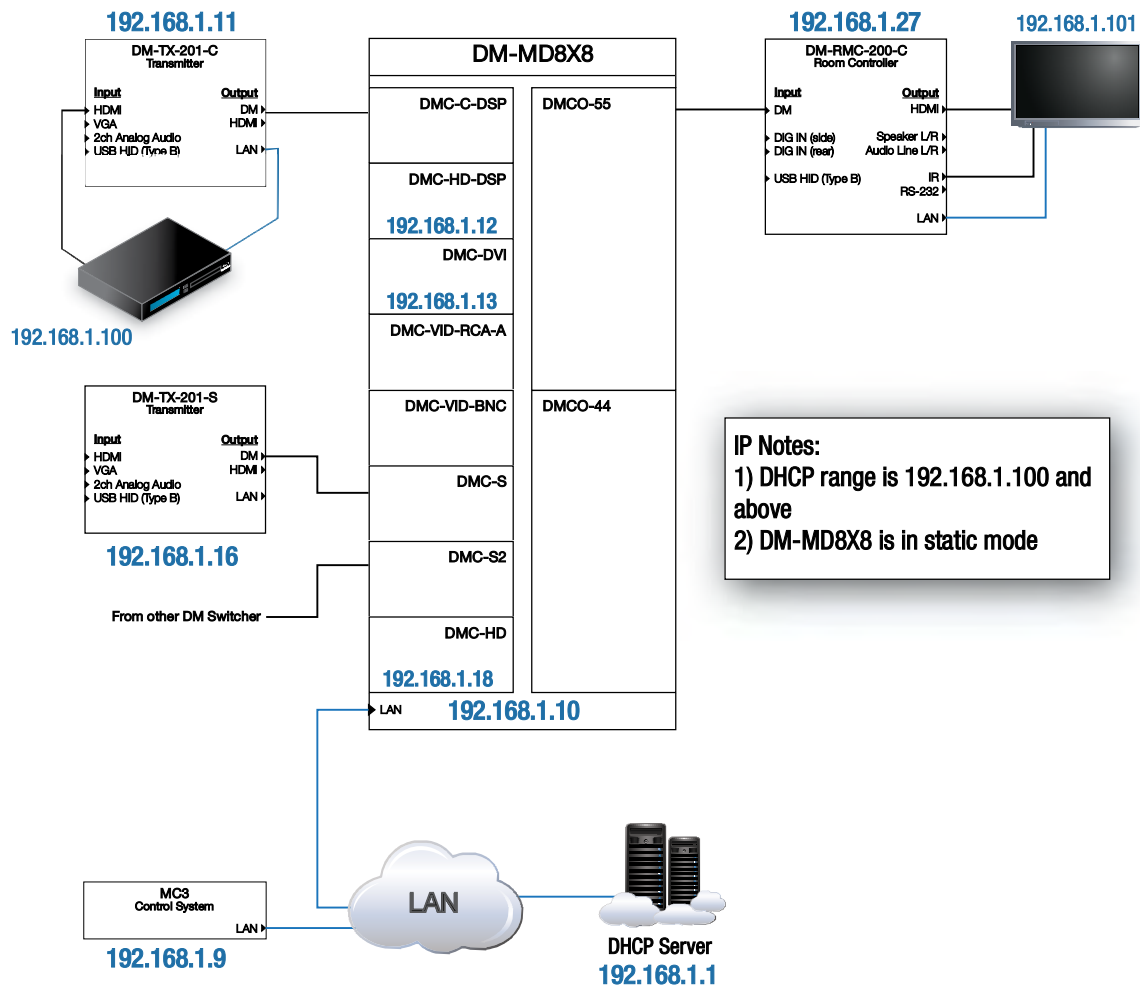
All DM products are Ethernet devices. Ethernet is transported via every DM connection. When using a DM-MD switcher at the core of the system, the Ethernet uplink occurs there (at the switcher), and Ethernet is distributed to the transmitter(s) or room box (or boxes) via the integrated 10/100 Ethernet switch contained in the switcher, making separate LAN connections unnecessary.

Each DM device (switcher, transmitter, room box) must receive an IP address, via either DHCP (server required) or static assigning.

Point to Point Systems



Switcher Based Systems



DM Room Controllers come fully equipped with an integrated Ethernet switch, and a spare port is provided. In a scenario where the room box is connected to a DM switcher, this port can be used for connecting other Ethernet devices. In a point-to-point scenario, the Ethernet port can be used as an uplink to the main network. For example, if a system contains a DM-TX-200 and a DM-RMC-100, the room controller must serve as the uplink point, since the DM-TX-200 does not provide an Ethernet port. But if the DM-TX-200 is replaced with a DM-TX-100 or DM-TX-300, the Ethernet uplink can occur at either the transmitter or the room controller, since both of these devices have an available Ethernet port.

NOTE: In point-to-point systems, only one of the devices should connect to the main network. In systems with switchers, the switcher should be the only device connected to the network. Refer to "Appendix D - DigitalMedia Network Considerations" on page 49 for details regarding IP and DM.



DATA SHEET

Polycom® SoundStructure SR12

Truly immersive audio experience for voice and video conferencing

The Polycom SoundStructure SR12 installed audio solution delivers powerful and flexible audio processing for any commercial sound application that does not require conferencing capabilities. Either alone or linked with up to seven additional systems, the SoundStructure SR12 system is an ideal solution for any sound

application, including houses of worship, stadiums, conference centers, hotels, night clubs, and restaurants. A powerful gain sharing automixer with automatic gain control on all inputs ensures consistent microphone pickup in all environments and flexible equalization, dynamics, and cross-over processing enable a broad range of applications. Feedback elimination on all inputs prevents embarrassing acoustic feedback and provides for flexible microphone and loudspeaker placement, and unrivaled noise cancellation technology removes the broadest range of background noises. A central matrix mixer that seamlessly scales from 12 up to 96 inputs and outputs makes setting up multi-zone audio systems a snap.

In addition, the SoundStructure model SR12 features the same flexibility and ease of installation as the SoundStructure C-Series conferencing products, and is a perfect way of adding 12 additional nonconferencing inputs (such as other line level audio sources) and outputs to a SoundStructure conferencing system. An innovative OBAM matrix architecture enables multiple SoundStructure units to work together as one large system for unparalleled scalability and flexibility. All SoundStructure products leverage advanced signal grouping, labeling and submixing that let you leverage yesterday's work during today's installation, saving time and money. Plus, exclusive SoundStructure Studio software from Polycom makes configuration easy, and is powerful enough to handle the most challenging acoustic designs.

About Polycom

Polycom is the global leader in standards-based unified communications (UC) solutions for telepresence, video, and voice powered by the Polycom® RealPresence® Platform. The RealPresence Platform interoperates with the broadest range of business, mobile, and social applications and devices. More than 400,000 organizations trust Polycom solutions to collaborate and meet face-to-face from any location for more productive and effective engagement with colleagues, partners, customers, specialists, and prospects. Polycom, together with its broad partner ecosystem, provides customers with the best TCO, scalability, and security for video collaboration, whether on-premises, hosted, or cloud-delivered. Visit www.polycom.com or connect with Polycom on Twitter, Facebook, and LinkedIn.

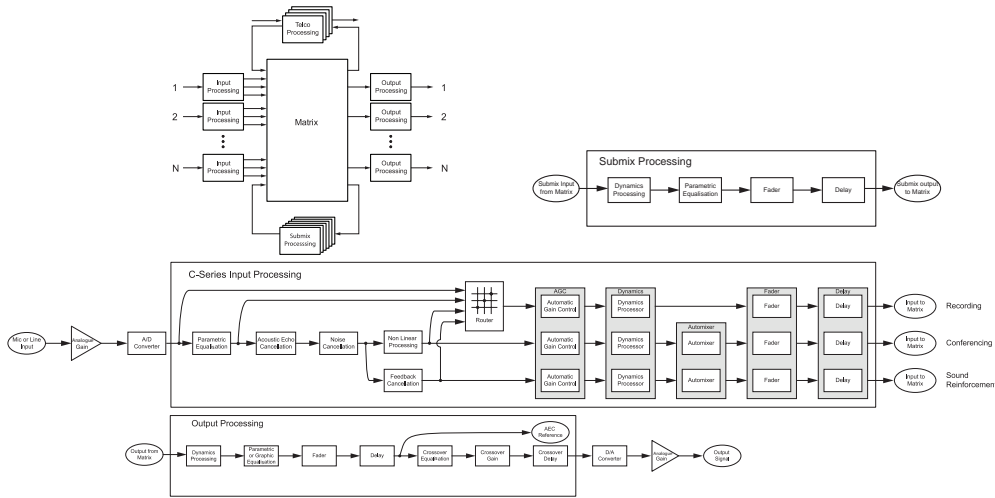


Benefits

- **Breakthrough feedback elimination** – Enables more flexible microphone, talker, and loudspeaker placements and speech reinforcement
- **Unrivaled noise cancellation technology** – Removes the broadest range of background noises from your audio inputs
- **Gain sharing automatic microphone mixer** – Improved automixer experience ensures smoother transitions and robust performance in a variety of operating environments
- **OBAM™ matrix architecture** – Connect multiple units together to create larger systems without the limitations of traditional bussing
- **SoundStructure Studio** – Powerful Windows-based software for efficient design and configuration; use it to easily set up a basic system, or use its powerful customization tools for more complex environments
- **Integrated Ethernet** – Control and manage the system from anywhere on the network

Polycom SoundStructure SR12 Specifications

Block Processing Diagram



Back of Unit



Dimensions

- 19" x 13.5" x 1.75" in (483 x 1343 x 45 mm) (W x L x H) (one rack unit)

Weight

- 12 lbs. (5.5 kg) dry, 14 lbs. (6.4 kg) shipping
- Connectors
- RS-232: DB9F
- OBAM In/Out: IEEE 1394B
- CLINK2 : RJ45
- LAN: RJ45
- Control /Status: DB25F
- Audio: Mini (3.5mm) quick connect terminal blocks
- IR Receive: Mini (3.5mm) quick connect terminal block

Power and Thermal

- Internal supply
- Input voltage of 90-250 VAC; 50-60 Hz; line power requirements (including 0.6 PF): 105VA (SR12)
- Thermal dissipation (Btu/hr): 215 Btu/hr
- 0 to 40°C operating temperature

Inputs

- Phantom power: 48 V DC through 6.8kOhm series resistor per leg, 7.5mA per channel, software selectable

- Analog input Gain: -20 to 64 dB on all inputs in 0.5 dB steps, software adjustable
- Maximum input amplitude: +20.4 dBu, 1% THD + N
- Nominal level: 0 dBu (0.775V rms)
- Equivalent input noise: <-122 dBu, 20 - 20,000 Hz, Rs=150 Ohms (1%)
- Input Impedance: 10 kOhms
- Input EMI Filter: Pi filter on all audio inputs

Outputs

- Output Gain: -100 to 20 dBu in 1 dB steps, software adjustable
- Maximum output amplitude: +23 dBu, 1% THD + N
- Nominal output level: 0 dBu (0.775 V rms)
- Output impedance: 50 Ohm, each leg to ground, designed to drive loads > 600 Ohms
- Output EMI Filter: Pi filter on all audio outputs

System¹

- Frequency response: 20-22,000 Hz, + 0.1/- 0.3 dB
- Idle channel noise: <-109 dB FS no weighting, 20 - 20,000 Hz, -60dB FS, 0.997 kHz input signal, 0 dB gain

- Dynamic range: >109 dB FS no weighting, 20 - 20,000 Hz, -60 dB FS, 0.997 kHz input signal, 0 dB gain
- Linearity: 0 dB FS to -122 dB FS +/- 1 dB
- THD+N: < 0.005%, -20 dB FS input signal
- Common Mode Rejection Ratio: <-61 dB, 20 - 20,000 Hz, no weighting
- Cross talk: <-110 dB, 20-20,000 Hz, 1kHz, channel-to-channel
- Latency: Mic/Line inputs to outputs: 5msec, 20 msec with NC processing enabled
- Noise cancellation: 0-20 dB, software selectable
- Control Inputs: Contact closure
- Status Outputs: Open collector 60V and 500mA maximum per output
- All signal ground pins connected to chassis ground through low impedance planes

¹ Unless noted, all values are valid for all channels at 0dB input gain

Polycom, Inc.
1.800.POLYCOM
www.polycom.com



The AXYS® Intellivox range

Digitally steerable, self powered, loudspeaker arrays.



Intellivox
DDS
Intellivox

Shaping the future of sound reinforcement

Identifying the problem

The AXYS Intellivox range is the perfect solution to one of the most difficult problems facing modern sound system designers - designing an intelligible sound reinforcement/public address system for a large reverberant space.

The modern sound system designer has to choose products that will fit a large range of criteria. The system must:

- Sound good
- Look good
- Be Safe and Reliable
- Be easy to install and maintain

All of these factors contribute to how the success of the installation will be judged.

So what happens when, as a designer, you're faced with a highly reverberant space?

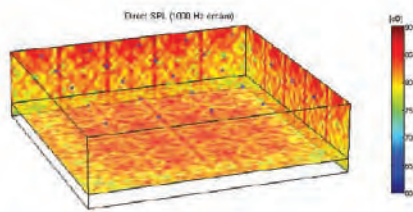
The biggest challenge is designing a system which will have a high direct to reverberant sound ratio. In other words, we need to maximise the sound that arrives directly to the listeners ear, whilst at the same time reducing the sound energy that bounces off walls, ceilings and other acoustically reflective surfaces.

The solution seems simple. However, in practice it is difficult to achieve this with conventional loudspeakers.

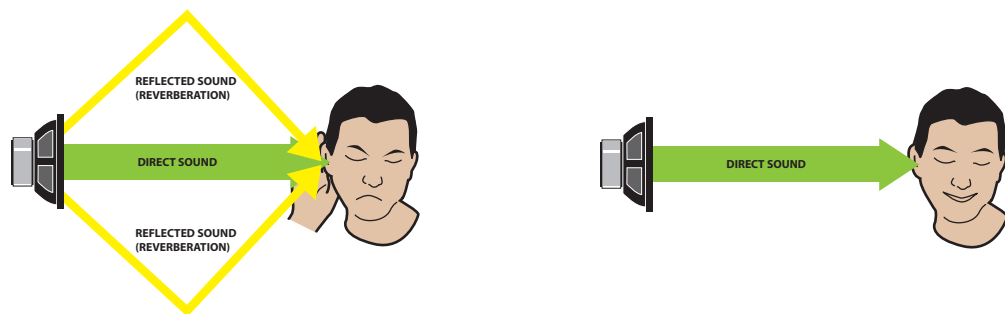
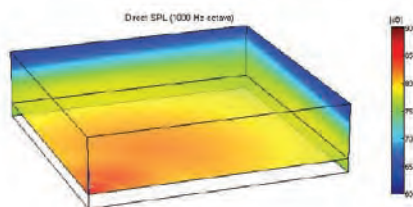
This is why Duran Audio developed the AXYS® Intellivox range.

Intellivox products use Duran Audio's highly advanced Digital Directivity Technologies - Digital Directivity Control (DDC) and Digital Directivity Synthesis (DDS), which allow you to control the vertical directivity pattern of Intellivox products and aim the sound where you want it - At the listener.

Direct SPL plot for traditional ceiling speakers

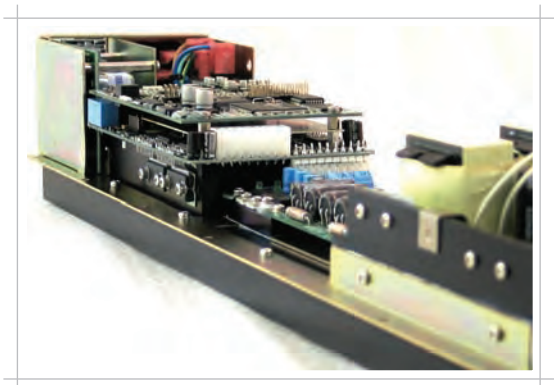


Direct SPL plot for single AXYS® Intellivox



The problems associated with a highly reverberant space can be improved considerably, by aiming the sound at the listener and away from acoustically reflective surfaces

To achieve such accurate directivity control from a loudspeaker array, the Intellivox has an integrated electronics module which combines powerful Digital Signal Processing with multi-channel class D amplifiers.



This electronics module comes network ready and can be controlled from the AXYS® WinControl software, which is used to setup and monitor Intellivox installations.

Also available is AXYS® DDA (Digital Directivity Analysis) which is a dedicated software tool that allows sound system designers to simulate and optimise the directional behaviour of the AXYS products.



An Intellivox-DS500 installed at St Pauls Cathedral, London, UK

What is speech intelligibility and why is it important?

The purpose of an announcement through any public address system is to communicate a message. An email with half of the words missing would not be an acceptable form of communication, so why should you accept a similar effect from a poor public address system? You shouldn't, an unintelligible public address system is unsatisfactory!

If you can't understand it why not just turn the volume up?

Imagine if someone ran up to you in the street and shouted information to your face! Wouldn't it be more comfortable if that person approached you calmly and addressed you in a clear well spoken voice at a more moderate volume?

A loud public address system isn't necessarily an intelligible one, and an intelligible system isn't necessarily a loud one.

With the arrival of digital audio we are all now used to high quality sound at home and on the move. This has set a new benchmark for quality. People now expect the same standard from a PA system without fully appreciating all the problems that exist in large spaces. The science of sound 'acoustics', is not a simple subject, the larger the room/space and the larger the system, the more difficult it becomes to maintain the quality.

Why choose AXYS® Intellivox?

A great sounding system

Quality Sound Reproduction – Delivering the ultimate intelligibility.

- Highly Intelligible speech reinforcement
- Natural sound reproduction
- High Direct to Reverberant ratio
- Free from distortion
- Even SPL coverage. (The volume from a properly set up Intellivox unit will be the same, whether the listener is at a distance or close up.)

(Digital Directivity Technologies ensure a high ratio of direct sound to reverberant sound which is critical to the intelligibility of any sound system)



Hill 16, Croke Park, Eire



US Naval Academy, USA



A great looking system

Architectural Integration – For systems that look great and sound great

- No need for mechanical aiming, units can be mounted vertically.
- Units can be recessed into surfaces
- Colour matching service available
- Units have a slim and unobtrusive design
- Can be integrated into buildings of all ages and styles



Covington Cathedral, USA

A safe and reliable system

Emergency Sound Systems – AXYS Intellivox products are designed for use in emergency sound systems.

- Designed to provide reliable operation
- In some cases, Intellivox products are the only way of achieving the required levels of speech intelligibility in a large reverberant space.
- All elements of Intellivox products are constantly monitored by the on board RISC processor.
- Faults can be reported via the built in failure relay or via the RS-485 network.
- Using 'WinControl service version' full fault logging of a system can be provided.

An easy to install and maintain system

Installation & Maintenance – Easy to install and maintain

- Fewer installation/maintenance points than conventional distributed systems
- Units can be configured from a single control point via an RS-485 network
- A wide range of mounting and cable entry options
- All parts & connections are accessible from the front as well as the rear of the unit making it possible to service the unit in situ
- Most units can be ordered with the electronics module at the top or bottom of the enclosure, allowing additional architectural flexibility



Brussels Airport, Belgium

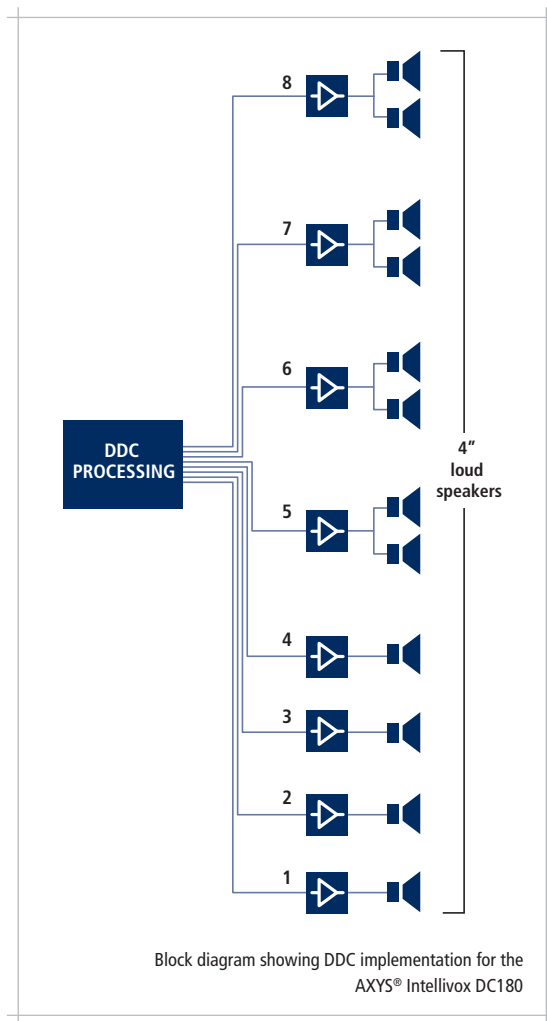


Paddington Station, UK

Intellivox DDC2.0 (Digital Directivity Control)

DDC stands for Digital Directivity Control, the 2.0 represents that this is the second generation of Intellivox DDC products from Duran Audio. DDC is a multi-channel loudspeaker array technology where the single loudspeaker elements are positioned in space according to a patented algorithm.

Each loudspeaker channel has its own dedicated audio path through the DSP and amplification which means that each loudspeaker, or group of loudspeakers, can have their own unique set of filters.



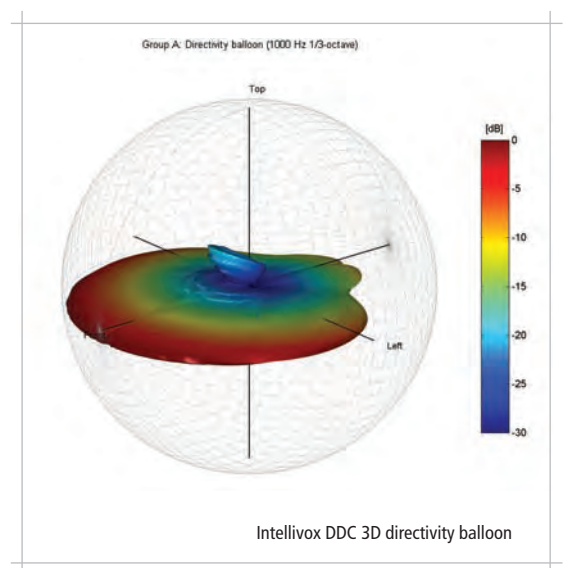
This technology enables users to electronically manipulate the vertical dispersion of an Intellivox array.

The Intellivox DDC2.0 range has the same beam steering parameters as its predecessors but with enhanced functionality and audio quality thanks to Duran Audio's new C6x DSP board.

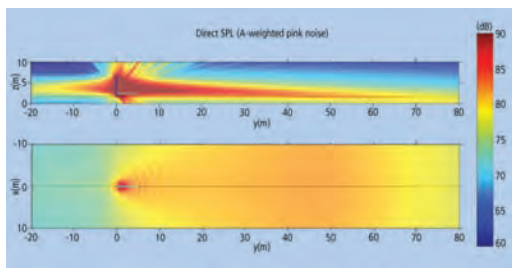
What does DDC2.0 have to offer?

The beam steering capability of the Intellivox means that you can maintain even coverage across the listening plane whilst steering the beam away from surfaces that may cause unwanted reflections.

This results in a very high direct to reverberant sound ratio which is essential for achieving acceptable levels of speech intelligibility within reverberant spaces. One way to visualise the dispersion is to imagine a pancake of sound coming from the array, by adjusting the elevation angle we can aim the pancake up or down from the acoustic centre. This technique also means that, unlike mechanically aimed passive arrays, the back radiated energy is also controlled. This control means that electronically aimed Intellivox arrays add far less energy to the reverberant field compared to conventional systems.



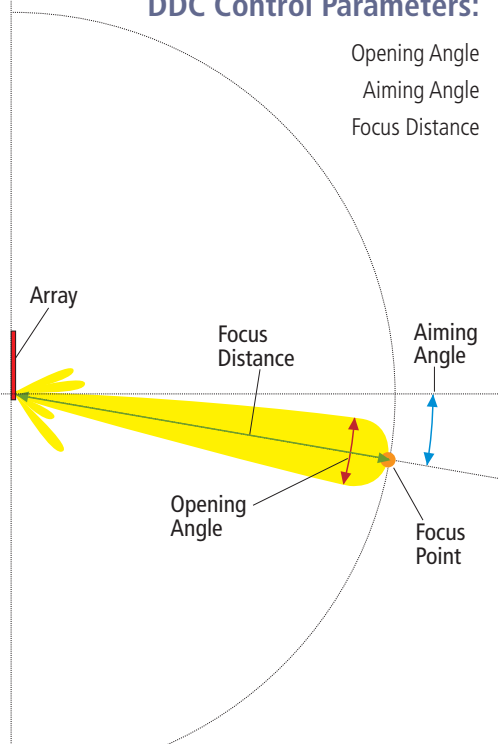
However, this is not the only benefit of the technology. DDC can also offer even SPL distribution over large distances. A well designed DDC installation can offer as little variation as 1 dB across the listening area. Taking an Intellivox DC500 as an example one can measure the SPL at 5 m and then measure again at 50 m and see as little as 1 dB variation.



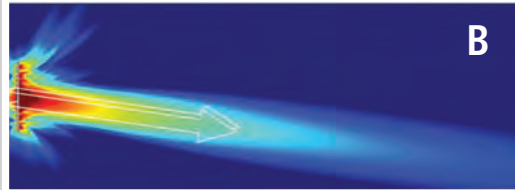
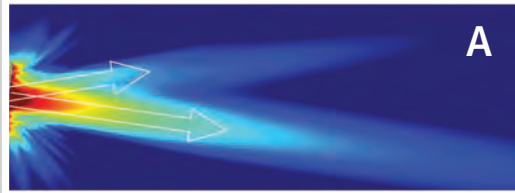
And for outdoor applications DDC technology can also offer solutions to problems associated with environmental noise pollution.

DDC Control Parameters:

Opening Angle
Aiming Angle
Focus Distance



In addition to the main lobe, DDC 2.0 also allows users to generate a second lobe from the array.



Mechanically aimed (A) versus electronically aimed (B) radiation pattern of a loudspeaker array mounted against a vertical surface.

The Intellivox is a digitally controlled loudspeaker which focuses the sound where you want it, at the listener.

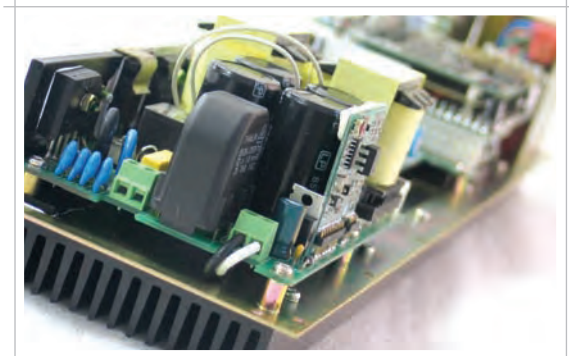
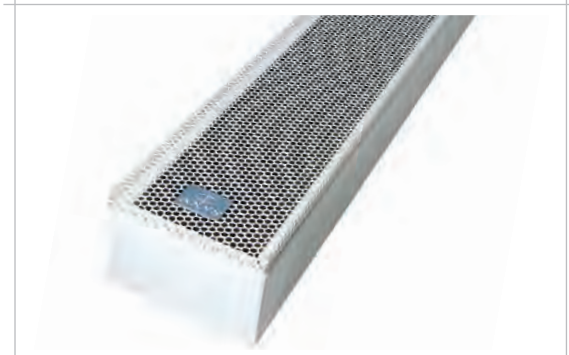
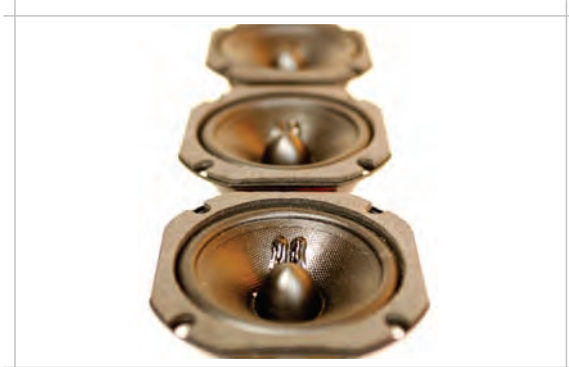
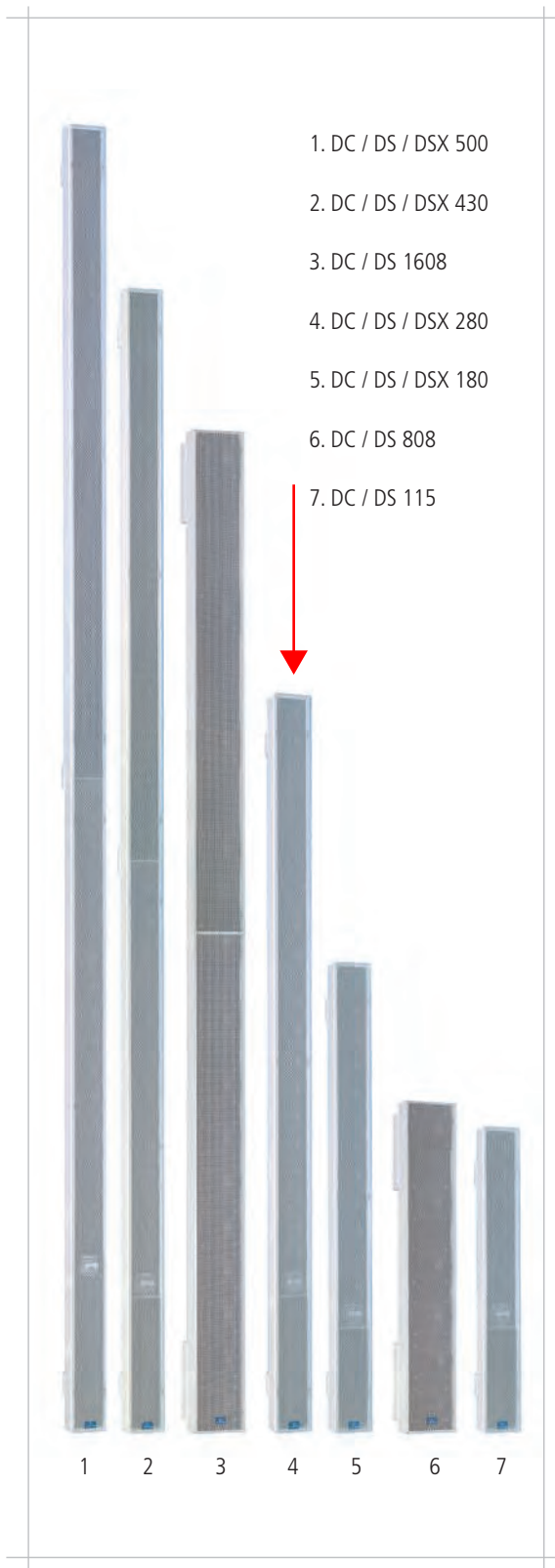
In visual terms it can be thought as a spot light as opposed to a flood light. Intellivox loudspeakers have a very narrow vertical coverage angle and a very wide horizontal coverage angle. In large reverberant spaces this type of loudspeaker has many benefits:

- The sound is digitally aimed at the listener
- There is less sound reflected from walls and ceilings therefore you hear less reflections.
- It is highly efficient at distributing the available power from the loudspeaker
- The SPL of the loudspeaker is approximately the same if you are close or if you are 60 m away

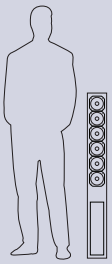
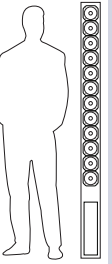
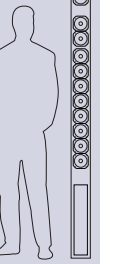
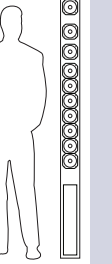
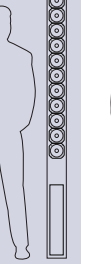
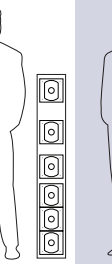
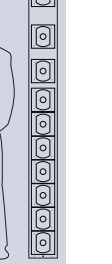
The result is a very natural, clear and direct sound, which is essential for achieving the required levels of speech intelligibility and getting your announcement understood.

Intellivox

The AXYS® Intellivox family



The AXYS® Intellivox DC family (DDC Technology)

	Ivx-DC115	Ivx-DC180	Ivx-DC280	Ivx-DC430	Ivx-DC500	Ivx-DC808*	Ivx-DC1608*
Frequency range (+/-3 dB)	130 - 20k Hz	130 - 10k Hz	130 - 10k Hz	130 - 10k Hz	130 - 10k Hz	130 - 18k Hz	130 - 18k Hz
Max SPL (A-weighted at 30 m) - Continuous - Peak	85 dB _{SPL} 88 dB _{SPL}	90 dB _{SPL} 93 dB _{SPL}	92 dB _{SPL} 95 dB _{SPL}	92 dB _{SPL} 95 dB _{SPL}	97 dB _{SPL} 100 dB _{SPL}	95 dB _{SPL} 105 dB _{SPL}	98 dB _{SPL} 108 dB _{SPL}
Coverage - Horizontal (fixed) - Vertical (adjustable) - Opening angle - Aiming angle - Focus distance - Typical Throw	130° 15° to 40° -16° to 16° 2 m to 40 m 15 m	130° 8° to 20° -16° to 16° 5 m to 100 m 25 m	130° 6° to 14° -16° to 16° 5 m to 100 m 35 m	130° 6° to 14° -16° to 16° 5 m to 100 m 50 m	130° 4° to 10° -16° to 16° 5 m to 100 m 70 m	110° 8° to 20° -20° to 20° 5 m to 100 m 25 m	110° 6° to 14° -20° to 20° 5 m to 100 m 50 m
Dynamic Range	>100 dB	>100 dB	>100 dB	>100 dB	>100 dB	>100 dB	>100 dB
Audio Inputs - Nominal level - Type (balanced) - Impedance (balanced)	0 dBV (line) transformer 6k8 Ω	0 dBV (line) transformer 6k8 Ω	0 dBV (line) transformer 6k8 Ω	0 dBV (line) transformer 6k8 Ω	0 dBV (line) transformer 6k8 Ω	0 dBV (line) transformer 6k8 Ω	0 dBV (line) transformer 6k8 Ω
Power amps - Type - Power (4 Ω)	PWM (class D) 8 x 40 W _{rms}	PWM (class D) 8 x 40 W _{rms}	PWM (class D) 8 x 40 W _{rms}	PWM (class D) 16 x 40 W _{rms}	PWM (class D) 16 x 40 W _{rms}	Class AB* 8 x 100 W _{rms} †	Class AB* 16 x 100 W _{rms} †
Mains Voltage Power Consumption -Idle -Full load	230 or 115 V 58 VA 325 VA	230 or 115 V 58 VA 408 VA	230 or 115 V 58 VA 450 VA	230 or 115 V 84 VA 750 VA	230 or 115 V 84 VA 920 VA	90 to 270 V 95 VA 760 VA	90 to 270 V 135 VA 1600 VA
Temperature range (ambient)	0 to 40 °C	0 to 40 °C	0 to 40 °C	0 to 40 °C	0 to 40 °C	0 to 40 °C	0 to 40 °C
Transducers	6 x 4" 2 x tweeter	12 x 4" -	16 x 4" -	17 x 4" -	32 x 4" -	6 x 6.5" 2 x Compression Drivers (1")	14 x 6.5" 2 x Compression Drivers (1")
Dimensions - Height - Width - Depth	1149 mm 134 mm 92 mm	1780 mm 134 mm 92 mm	2800 mm 134 mm 92 mm	4350 mm 134 mm 92 mm	4930 mm 134 mm 92 mm	1278 mm 198 mm 156 mm	3738 mm 198 mm 156 mm
Default Colour	RAL 9010	RAL 9010	RAL 9010	RAL 9010	RAL 9010	RAL 9010	RAL 9010
Weight	13 kg	19 kg	25 kg	37 kg	44 kg	37 kg	78 kg
							
	Ivx-DC115	Ivx-DC180	Ivx-DC280	Ivx-DC430	Ivx-DC500	Ivx-DC808*	Ivx-DC1608*

* The Ivx-DC808 and Ivx-DC1608 come with the electronics separated in a 3RU enclosure.

† For 8 Ω load

LS-16

ADA Standard Stationary FM System



Configurations

- LS-16-072-01 (North America)
- LS-16-216-01 (North America)

The LS-16 is specifically designed to meet the needs of the 2010 Americans with Disabilities Act (ADA) standards for accessible design. In addition to ensuring that public facilities are compliant; the system helps solve frustrating but common sound problems caused by distance, background noise, or poor room acoustics. The system includes a Stationary Transmitter and Universal Antenna Kit, Rack Mounting Kit, LR-400 Receivers with Ear Speakers and neck loop, alkaline batteries and Assistive Listening Notification Signage Kit. The system can be ordered on either the 72 or 216 MHz frequency band, and can be customized if you need additional parts. Great solution to enrich your customers' listening experience in classrooms, public meeting rooms, theaters, stadiums, concert halls, and more.

Highlights

- Meet the requirements of the new 2010 ADA standards and deliver an enriched listening experience. Standard system can be designed to meet the needs for any venue.
- Available in 72 MHz or 216 MHz.
- Superior audio quality – 80 dB signal-to-noise ratio (SNR), setting the industry's sound quality standard.
- 100 % Digital – Listen receivers are digitally-tuned so the transmission won't drift.
- Long transmission range ensures coverage for the entire venue.
- Try before you buy - free no obligation 30 day demo.
- Limited Lifetime Warranty with hassle-free support.

Includes

- (1) LT-800 Stationary FM Transmitter (72 or 216 MHz)
- (1) LA-122 Universal Antenna Kit (72 and 216 MHz)
- (1) LA-326 Universal Rack Mounting Kit
- (4) LR-400 Portable Display FM Receiver (72 or 216 MHz)
- (4) LA-164 Ear Speaker
- (2) LA-166 Neck Loop
- (4) LA-361 High Capacity AA Alkaline Batteries (2)
- (1) LA-304 Assistive Listening Notification Signage Kit

Accessories*



LA-321 8-Unit Portable FM Product Charging/Carrying Case

Store and charge up to 8 portable FM units in this hard sided, locking case (NiMH batteries required). Features easy, drop-in automatic charging. Use to charge units with NiMH batteries.



LA-317 4-Unit Portable FM Products Charging/Carrying Case

Store and charge up to 4 portable FM units in this hard-sided, locking case (NiMH batteries required).



LA-208 7.5 VDC Power/Charging Supply for FM Portable Products

Use to charge Listen's portable products.



LA-362 Rechargeable AA NiMH Batteries (2)

Longer life than NiCAD without the "memory effect". Required for use in charging cases. Package of 2 batteries.

*See www.shoplisten.net or call Listen for full range of accessories

TSW-750

7" Touch Screen

- > Ultra clean, modern appearance
- > Thin profile and small footprint
- > Affordable and easy to install
- > 7" widescreen active-matrix color display
- > Core 3 UI™ graphics^[1]
- > 800 x 480 WVGA display resolution
- > Capacitive touch screen technology
- > High-performance H.264 streaming video
- > Rava™ SIP intercom and phone technology
- > Customizable audio feedback
- > Built-in microphone and speakers
- > 5 soft-touch capacitive buttons
- > Single-wire Ethernet connectivity
- > PoE network powered
- > Standard electrical wall box mounting^[4]
- > Available tabletop and swivel mount options^[2]
- > Available in smooth black or white finish

Advanced Touch Screen Control

A Crestron® touch screen offers an ideal user-interface for controlling all the technology in your home, boardroom, classroom, courtroom, or command center. Touch screens do away with piles of remote controls, cluttered wall switches, and cryptic computer screens, simplifying and enhancing the way you use technology. For controlling home theater, multimedia presentation, audio, video, lighting, HVAC, and other systems, Crestron touch screens are fully-customizable with easy-to-use controls and icons, true feedback and real-time status display, live streaming video, and advanced navigation of digital media servers, tuners, and other devices.

With its clean, contemporary design highlighted by edge-to-edge glass and stunning Core 3 UI™ color graphics, the Crestron TSW-750 touch screen makes an elegant statement on any wall, tabletop or lectern. Perfectly at home in the most contemporary residence or modern office building, its high-tech good looks underline its power for simplifying everyday tasks and functions throughout any facility.

The TSW-750 delivers the ultimate touch screen experience in an unobtrusive, space-saving design featuring a brilliant 7 inch capacitive touch screen display and 5 soft-touch buttons. PoE connectivity and standard gang-box mounting make installation a breeze for both new and retrofit applications. Additional features include high-performance H.264 video, Rava™ SIP Intercom, and advanced Core 3 UI touch screen graphics.

Powered by Core 3™^[1]

Crestron touch screens have always offered the ultimate user experience. With Core 3 UI, they also deliver the ultimate value, enabling the creation of dynamically rich user interfaces with incredible efficiency and unparalleled functionality. Using Core 3 UI, programmers can swiftly integrate fluid gesture-driven controls, animated feedback, metadata,



embedded apps, and full-motion video for a deeply engaging and ultra-intuitive touch screen experience.

Some Core 3 UI enhancements:

- Cool-looking graphical buttons, sliders, knobs, and gauges are intuitive and fun to use.
- Kinetic effects enhance the feeling of realism with lists and toolbars that scroll with momentum at the flick of a fingertip.
- Drag-and-drop objects snap into place offering an easy way to assign assets to rooms.
- Desktop widgets personalize the touch screen with animated clocks, calendars, weather, news, and other information.
- Customizable themes allow a completely different look and feel for every user, event, or season.
- Fully-developed SmartObjects™ enable sophisticated control over complex devices with minimal programming.
- Smart Sizing™ scales objects perfectly and instantly for faster GUI development — even across different sized touch screens.

Soft-Touch Buttons

The TSW-750 includes five soft-touch capacitive buttons for quick access to commonly used functions. The buttons are pre-labeled with icons for “Power”, “Home”, “Lights”, “Up”, and “Down” functions. Each button is programmable via the control system for custom functionality.

Streaming Video

High-performance streaming video capability makes it possible to view security cameras and other video sources over the network right on the touch screen. Native support for H.264 and MJPEG formats allows the TSW-750 to display live video images from Web cameras and servers such as the Crestron [CEN-NVS200 Network Video Streamer](#)^[2].

TSW-750 7" Touch Screen



TSW-750-W-S – Rear and Front Views

Rava™ SIP Intercom

Rava SIP Intercom Technology enables hands-free VoIP communication between any two Rava-enabled Crestron touch screens. Rava works over Ethernet, supporting 2-way intercom, video intercom^[3], paging, and room monitoring without any special wiring. VoIP phone capability is also possible through integration with an SIP-compatible IP phone system or SIP server, allowing hands-free telephone functionality complete with speed-dialing, caller ID, custom ringers, and other enhancements. Built-in echo cancellation affords true-duplex performance for clear, seamless voice communication using the TSW-750's integrated microphone and speakers.

Audio Feedback

Customized audio files can be loaded to add another dimension to the touch screen graphics using personalized sounds, button feedback, and voice prompts.



TSW-750-B-S with TSW-750-TTK TableTop Mounting Kit

Single-Wire Connectivity

A simple Ethernet LAN connection is all that is required to wire the TSW-750, containing all control, video, intercom, and power signals within a single wire.

Power over Ethernet

Using PoE technology, the TSW-750 gets its operating power right through the LAN wiring. PoE (Power over Ethernet) eliminates the need for a local power supply or any dedicated power wiring. A PoE Injector (PWE-4803RU^[2]) simply connects in line with the LAN cable at a convenient location. Crestron PoE switches (CEN-SW-POE-5, CEN-SW-POE-16 or CEN-SW-POE-24^[2]) may also be used to provide a total networking solution with built-in PoE.

Simple, Versatile Mounting

The TSW-750 installs easily over a 2-gang or 3-gang electrical box, or a 2-gang European electrical box. It can also be attached directly to drywall and other surfaces over the front of a 2-3/8" H x 3-3/8" W (60mm H x 86mm W) cutout. When installed, it protrudes just 1/2 inch from the mounting surface and is magnetically adhered to its mounting bracket, eliminating any visible screws for an ultra clean appearance.^[4]

TableTop Option

Using the optional TableTop Kit (TSW-750-TTK^[2]), the TSW-750 becomes a stylish, freestanding touch screen that fits perfectly on a table, desk, or countertop. It can even be permanently attached to the surface using the optional Swivel Mount Kit (TSW-550/750/1050-SMK^[2]).

SPECIFICATIONS

Touch Screen Display

Display Type: TFT Active matrix color LCD

Size: 7 inch (178 mm) diagonal

Aspect Ratio: 15:9 WVGA

Resolution: 800 x 480 pixels

TSW-750 7" Touch Screen

Brightness: 300 nits (cd/m²)

Contrast: 350:1

Color Depth: 18-bit, 262k colors

Illumination: Edgelit LED

Viewing Angle: ±70° horizontal, ±65° vertical

Touch Screen: Projected Capacitive

Buttons

Hard Keys: (5) Projected capacitive pushbuttons, programmable, pre-labeled with icons for "Power", "Home", "Lights", "Up", and "Down"

Reset: (1) Miniature pushbutton on rear panel for hardware reset

Memory

LPDDR2 RAM: 1 GB

Flash: 4 GB

Maximum Project Size: 512 MB

Graphics Engine

Core 3 UI™ [1]

Communications

Ethernet: 10/100 Mbps, auto-switching, auto-negotiating, auto-discovery, full/half duplex, DHCP, IEEE 802.3af and 802.3at Type 1 compliant

Video

Streaming Formats: H.264 (MPEG-4 part 10 AVC), MJPEG

Audio

Features: Built-in microphone and speakers, Rava™ SIP Intercom

Audio Feedback Formats: MP3

Connectors

LAN PoE: (1) 8-wire RJ45 with 2 LED indicators;

10Base-T/100Base-TX Ethernet port;

Power over Ethernet compliant;

Green and yellow LEDs indicate Ethernet port status

Power Requirements

Power over Ethernet: IEEE 802.3af (802.3at Type 1) Class 3 PoE Powered Device

Environmental

Temperature: 32° to 112°F (0° to 45°C)

Humidity: 10% to 90% RH (non-condensing)

Heat Dissipation: 44 BTU/hr

Enclosure

Construction: Plastic, smooth black or white finish

Mounting: Surface mount over a 2 or 3-gang electrical box, 2-Gang

European (DIN 49073) electrical box, or 2-3/8" H x 3-3/8" W (60mm H x 86mm W) cutout⁽⁴⁾; optional tabletop kit sold separately

Dimensions

Height: 4.74 in (121 mm)

Width: 7.59 in (193 mm)

Depth: 2.03 in (52 mm)

Weight

14.1 oz (400 g)

MODELS & ACCESSORIES

Available Models

TSW-750-B-S: 7" Touch Screen, Black Smooth

TSW-750-W-S: 7" Touch Screen, White Smooth

Available Accessories

TSW-750-TTK: TableTop Kit

TSW-550/750/1050-SMK: Swivel Mount Kit for TSW-750-TTK

PWE-4803RU: PoE Injector

CEN-SW-POE-5: 5-Port PoE Switch

CEN-SWPOE-16: 16-Port Managed PoE Switch

CEN-SWPOE-24: 24-Port Managed PoE Switch

CEN-NVS200: Network Video Streamer

SW-VMK-WIN: TouchPoint® Virtual Mouse & Keyboard Software for Windows®

Notes:

1. Supports Core 3 UI only. Not compatible with pre-Core 3 UI projects.
2. Item(s) sold separately.
3. H.264 compatible IP camera required.
4. For proper positioning of the touch screen unit, the electrical box or cut-out must be positioned approximately 1/4" to the right of center, and 1/10" above center.

This product may be purchased from an authorized Crestron dealer. To find a dealer, please contact the Crestron sales representative for your area. A list of sales representatives is available online at www.crestron.com/salesreps or by calling 800-237-2041.

Specifications subject to change without notice. Crestron is not responsible for errors in typography or photography.

The specific patents that cover Crestron products are listed online at: patents.crestron.com.

Core 3, Core 3 UI, Crestron, Rava, SmartObjects, Smart Sizing, TouchPoint, and the Crestron logo are either trademarks or registered trademarks of Crestron Electronics, Inc. in the United States and/or other countries. Windows is either a trademark or registered trademark of Microsoft Corporation in the United States and/or other countries. Other trademarks and trade names may be used in this document to refer to either the entities claiming the marks and names or their products. Crestron disclaims any proprietary interest in the marks and names of others. ©2012 Crestron Electronics, Inc.

MPC Media Presentation Controller™ M10

Crestron MPC is a family of 2-Series control systems designed for installation in a wall or podium, delivering the industry's best multimedia room control technology in a convenient, space-saving design. Perfect for classrooms, meeting rooms, lecture halls, and training facilities, the MPC-M10 provides a fully-programmable user interface featuring an attractive and intuitive layout of pushbuttons with customizable backlit labeling, volume control, and wireless remote capability.

Available in white or black, the MPC-M10 is constructed to handle the rigors of everyday use in a corporate or educational environment. An assortment of programmable control ports provides connectivity for audio, video, and lighting equipment. The onboard e-Control® Web server provides for complete integration as part of a facility-wide managed control network.

Control...Simplified

The MPC-M10 is engineered to be easy to integrate and use, yet versatile enough to suit each application perfectly. Its 10 programmable "hard key" buttons can be freely programmed for system power, input source selection, transport control, lighting presets, and any other functions. Custom backlit labeling of the buttons is facilitated using an assortment of pre-printed labels or Crestron Engraver software. Adjusting audio volume and other parameters is enabled using the continuous-turn control knob and LED bargraph.

Configuring a complete media presentation control solution is simplified using Crestron SystemBuilder™ software, allowing limitless programmability from the award-winning platform that's familiar to every Crestron dealer. The MPC Wizard included in SystemBuilder enables setup of a full-featured presentation system complete with lighting control and RoomView® remote management without requiring any programming. Uploading and updating a facility full of MPC systems is managed easily over the network, or individually via the front panel USB port.

Wireless Remote

A range of options is available for adding wireless remote control to the MPC system. Its built-in IR receiver allows use of any Crestron IR wireless touchpanel or handheld remote without requiring a separate receiver or gateway. For greater range and freedom of movement, MPC also supports Crestron's full line of RF wireless and WiFi based products.

Wired Expansion

Adding a second control panel or just adding a few more buttons is easy using the MP-B10 and MP-B20 Media Presentation Button Panels. Of course, with Cresnet® and Ethernet built-in, the MPC-M10 works seamlessly with Crestron's entire line of keypads and touchpanels, lighting dimmers and shade controllers, signal processors and switchers, and much more.

Built-in Control Ports

Through its onboard control ports, the MPC-M10 interfaces directly with the video display or projector, DVD player or TV receiver, projection screen, lift, occupancy sensor, and other devices in the room. In addition to Cresnet and high-speed Ethernet, there is a bidirectional RS-232 COM port, an IR/serial port, two relays, and four input ports right on the rear panel.

Audio and Video Control



The MPC-M10 is ideal for small room systems utilizing a single display device with computers and other sources connected directly to it. But like any 2-Series control system, MPC is fully scalable to suit larger applications with several program sources, microphones, or even multiple displays. Simply add a C2N-VEQ4 module to enable 4 channels of audio volume and EQ control. Or, use any of Crestron's QuickMedia® wall plate and FlipTop interfaces, switchers, and receivers for a total signal routing, processing, and amplification solution.

Ethernet and e-Control®2

Built-in 10/100 Ethernet facilitates secure high-speed network connectivity, enabling extensive capabilities for remote system maintenance and control, and providing an interface to other Crestron control systems. The onboard Web server provides the foundation for Crestron's exclusive e-Control 2 Xpanel technology, providing secure IP-based remote control. SSL encryption prevents hackers from breaching the system and accessing its controls.

RoomView® and SNMP

The MPC-M10 communicates directly with Crestron's exclusive RoomView help desk software, the industry's most comprehensive facility-wide solution for remote monitoring and asset management. Built-in SNMP support also enables integration with third-party network management software, allowing full control and monitoring from the IT Help Desk or NOC in a format that's familiar to IT personnel.

Cresnet® Slave Mode

Selectable Cresnet Slave Mode enables the MPC-M10 to become a Cresnet keypad controller and expansion module as part of a larger Crestron system, providing a user-interface with local control ports built in for interfacing to nearby devices.

Ambient Light Sensor

The MPC-M10's built-in light sensor has a range of uses, from controlling its own backlight intensity, to providing ambient lighting level data to a central building management system.

> *Wall mount 2-Series control system*

> *10 programmable buttons with LED feedback*

MPC-M10 MPC Media Presentation Controller™ M10

- > Customizable backlit button labels
- > Volume control knob and LED bargraph
- > Built-in IR receiver and light sensor
- > RS-232, IR, 4 input, & 2 relay control ports
- > Cresnet and 10/100 Ethernet
- > e-Control Web server
- > RoomView and SNMP support
- > SSL (Secure Sockets Layer) network protection
- > Setup via SystemBuilder software
- > Rugged construction
- > 3-gang wall-mountable
- > Includes external Cresnet power supply

SPECIFICATIONS

Processor

CPU: 32-bit Freescale ColdFire® Microprocessor

Memory

SDRAM: 32 MB

NVRAM: 256 KB

Flash: 8 MB

Operating System

Real-time, preemptive multi-threaded/multitasking kernel; FAT32 file system with long names; supports SIMPL™ Windows® and SIMPL+®

Ethernet

10/100BaseT, auto-negotiating, full/half duplex, static IP or DHCP, DNS, SSL, TCP/IP, UDP/IP, CIP, SMTP, SNMP, built-in Web server and e-mail client; supports Crestron e-Control® 2 XPanel and RoomView® applications

Connectors

NET: (2) sets of (4) captive screw terminals; Cresnet port and 24 Volt DC power input with parallel pass-thru; Master/Slave selectable

LAN: (1) 8-wire RJ45 with 2 LED indicators; 10/100BaseT Ethernet port; Green LED indicates link status; Yellow LED indicates Ethernet activity

COM: (5) captive screw terminals; Bidirectional RS-232 port; Up to 115.2k baud; hardware and softwarehandshaking support

RELAYS 1 - 2: (3) captive screw terminals comprising (2) normally open, isolated relays (with shared common); Rated 1 Amp, 30 Volts AC/DC; MOV arc suppression across contacts

IR: (2) captive screw terminals; IR/Serial output port; IR output up to 1.2 MHz; 1-way serial TTL/RS-232 (0-5 Volts) up to 115.2k baud
INPUTS 1 - 4: (5) captive screw terminals comprising (4) digital or analog input ports (referenced to GND); Digital Input: Rated for 0-24 Volts DC, input impedance 20k ohms, logic threshold 1.25 Volts DC; Analog Input: Rated for 0-10 Volts DC, protected to 24 Volts DC maximum, input impedance 20k ohms;

Controls and Indicators

Hard Keys: (10) Programmable pushbuttons with backlit labeling
Feedback Indicators: (10) Programmable red LEDs (1 per hard key)
VOLUME: (1) Programmable continuous turn rotary encoder
Bargraph: (1) Programmable red 5-segment LED bargraph
HW-R: (1) Recessed miniature pushbutton for hardware reset (reboots the processor)
SW-R: (1) Recessed miniature pushbutton (behind front cover) for software reset (restarts the SIMPL program)

Light Sensor

Photosensor, programmable for auto-dimming of front panel labeling and other functions

IR Receiver

Reception Frequency: 36 to 38 kHz IR

Formats: Crestron format, RC5

Range: Up to 50 ft line of sight (typical), dependent upon angle, obstructions, IR interference, and IR remote signal strength

Power Requirements

Cresnet Power Usage: 9 Watts (0.375 Amps @ 24 Volts DC);

PW-2407RU power supply included

Available Cresnet Power: 9 Watts using PW-2407RU (included)

Environmental

Temperature: 32° to 104°F (0° to 40°C)

Humidity: 10% to 90% RH (non-condensing)

Heat Dissipation: 17 BTU/hr

Enclosure

Faceplate: High-impact plastic, black or white, with polycarbonate label overlay

Chassis: Injection-molded plastic with steel mounting plate

Mounting: Requires 3-gang plaster ring or electrical box (≥2.5 inch deep recommended)

Dimensions

Height: 4.50 in (11.43 cm)

Width: 6.70 in (17.02 cm)

Depth: 2.23 in (5.67 cm)

Weight

1.33 lb (0.61 kg)

Available Models

MPC-M10-B-T: Media Presentation Controller™ M10, Black

MPC-M10-W: Media Presentation Controller™ M10, White

Included Accessories

PW-2407RU 18 Watt Cresnet® Power Supply, US/International [Included Quantity for MPC-M10-B-T, MPC-M10-W: 1]

Available Accessories

MP/MPC/IPAC_FRONT_LABEL_ENGRAVED-B-T: Custom Engravable Backlit Labels, Black

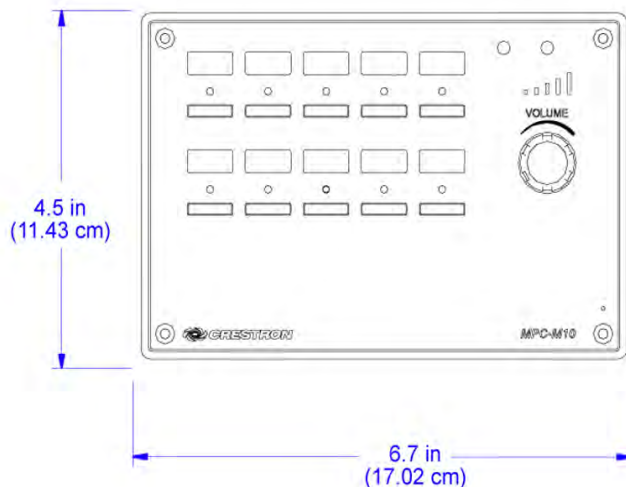
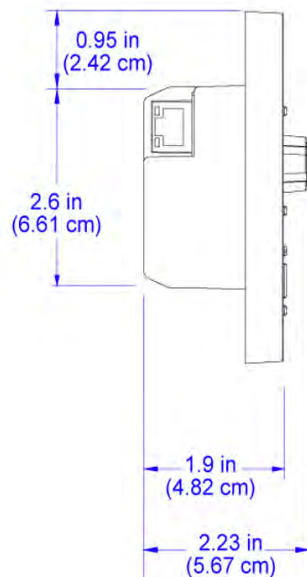
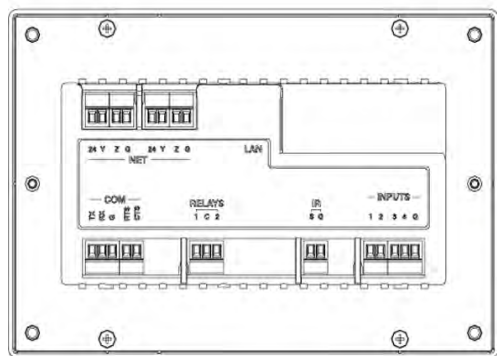
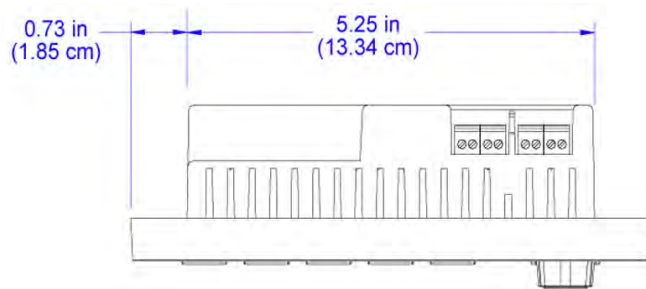
MP/MPC/IPAC_FRONT_LABEL_ENGRAVED-W: Custom Engravable Backlit Labels, White

TTK-MP/MPC/IPAC-B-T: Table Top Kit, Black

MPC-M10 MPC Media Presentation Controller™ M10

TTK-MP/MPC/IPAC-W: Table Top Kit, White
SMK-MP/MPC/IPAC: Swivel Mount Kit
CNSP-XX: Custom Serial Interface Cable
IRP2: IR Emitter Probe
MP-B10-B-T: Media Presentation Button Panel B10, Black
MP-B10-W: Media Presentation Button Panel B10, White
MP-B20-B-T: Media Presentation Button Panel B20, Black
MP-B20-W: Media Presentation Button Panel B20, White
MP-WP100-B: Media Presentation Wall Plate - RCA Composite Video w/RCA Stereo Audio, Black
MP-WP100-W: Media Presentation Wall Plate - RCA Composite Video w/RCA Stereo Audio, White
MP-WP110-B: Media Presentation Wall Plate - Mini-DIN S-Video w/RCA Stereo Audio, Black
MP-WP110-W: Media Presentation Wall Plate - Mini-DIN S-Video w/RCA Stereo Audio, White
MP-WP120-B: Media Presentation Wall Plate - RCA Component Video w/RCA Stereo Audio, Black
MP-WP120-W: Media Presentation Wall Plate - RCA Component Video w/RCA Stereo Audio, White
MP-WP125-B: Media Presentation Wall Plate - RCA Component & Composite Video w/2x RCA Stereo Audio, Black
MP-WP125-W: Media Presentation Wall Plate - RCA Component & Composite Video w/2x RCA Stereo Audio, White
MP-WP130-B: Media Presentation Wall Plate - DB15HD Computer VGA w/ Mini-TRS Stereo Audio, Bulkhead, Black
MP-WP130-W: Media Presentation Wall Plate - DB15HD Computer VGA w/ Mini-TRS Stereo Audio, Bulkhead, White
MP-WP131-B: Media Presentation Wall Plate - DB15HD Computer VGA w/ Mini-TRS Stereo Audio, Breakout, Black
MP-WP131-W: Media Presentation Wall Plate - DB15HD Computer VGA w/ Mini-TRS Stereo Audio, Breakout, White
MP-WP140-B: Media Presentation Wall Plate - DVI-I w/Mini-TRS Stereo Audio, Black
MP-WP140-W: Media Presentation Wall Plate - DVI-I w/Mini-TRS Stereo Audio, White
MP-WP150-B: Media Presentation Wall Plate - HDMI® w/Mini-TRS Stereo Audio, Black
MP-WP150-W: Media Presentation Wall Plate - HDMI® w/Mini-TRS Stereo Audio, White
MP-WP152-B: Media Presentation Wall Plate - HDMI®, Black
MP-WP152-W: Media Presentation Wall Plate - HDMI®, White
MP-WP160-B: Media Presentation Wall Plate - DisplayPort w/Mini-TRS Stereo Audio, Black
MP-WP160-W: Media Presentation Wall Plate - DisplayPort w/Mini-TRS Stereo Audio, White
MP-WP162-B: Media Presentation Wall Plate - DisplayPort, Black
MP-WP162-W: Media Presentation Wall Plate - DisplayPort, White
MP-WP180-B: Media Presentation Wall Plate - QuickMedia®, Black
MP-WP180-W: Media Presentation Wall Plate - QuickMedia®, White
MP-WP185-B: Media Presentation Wall Plate - DigitalMedia™ CAT, Black
MP-WP185-W: Media Presentation Wall Plate - DigitalMedia™ CAT, White
MP-WP186-B: Media Presentation Wall Plate - DigitalMedia™ Fiber, Black
MP-WP186-W: Media Presentation Wall Plate - DigitalMedia™ Fiber, White
MP-WP190-B: Media Presentation Wall Plate - Cresnet®, Black
MP-WP190-W: Media Presentation Wall Plate - Cresnet®, White
MP-AMP30: Media Presentation Audio Amplifier
SW-ROOMVW-ENT: RoomView® Express - Remote Help Desk and Resource Management Software
SW-ROOMVW-SERVER: RoomView® Server Edition - Enterprise Management and Scheduling Software [Discontinued]

MPC-M10 MPC Media Presentation Controller™ M10





Polycom® VSX™ 7000e

Award-winning mainstream video conferencing system offers you more flexibility than ever before



Benefits

Sleek video component design – 1U height rack-mountable system plus PowerCam™ camera including a microphone array and remote control

Superior, natural sound – Polycom StereoSurround™ delivers crisp, natural voice clarity - even when multiples parties are speaking simultaneously – by using dual channel, Siren™ 14 technology

Outstanding video – Premium quality video at any bandwidth with smooth natural motion and sharp, clear images. Employs standard-based H.264 compression and Pro-Motion™ video for optimal viewing

Multimedia made easy – Show high-res images, movies or presentations in your meetings while also sharing video. And, you can connect your PC directly to the VSX 7000e or share content cable-free using Polycom's unique People+Content™ IP technology

Flexible connections – Supports multiple camera and displays including single XGA monitors, high resolution document camera, DVD and VCR for playback and record

Simplified dialing and enhanced performance – Integrate the SoundStation VTX 1000 to launch video calls, capture soft voices clearly from across the entire room in StereoSurround and eliminate the need for microphones and wires

Complete solution packages – Combine the VSX 7000e with any of Polycom's attractive furniture display options to create a total meeting room solution

The Polycom Solution – Everything you need to deploy and manage a complete video conferencing network with Polycom Global Management System™, Polycom PathNavigator™, Polycom Conference Suite™ and the Polycom MGC™

Introducing the Polycom VSX 7000e, a split video conferencing solution for medium to large-sized conference rooms.

Designed for flexibility, the Polycom VSX 7000e split systems are ideal for medium to large conference rooms where there is a requirement to have the camera and video system separated; for instance, configurations that include plasma or LCD displays or projection screens. The VSX 7000e configurations include a wide range of options that will match the needs of most meeting rooms, options such as data sharing, multiple cameras and video bridging capability.

Like the other award-winning products in the VSX line, the VSX 7000e includes Polycom StereoSurround™ for the best audio in the market, as well as Polycom Pro-Motion™ for optimal motion handling and video resolution. VSX 7000e customers can combine the SoundStation VTX1000® conference phone with their system, allowing them to make video calls through their conference phone and to use it as their stereo microphone, eliminating clutter and wires on the conference table. Take your choice of how you want to call – IP (H.323 and SIP) or ISDN – and be assured that your video conference is secure with the most up-to-date encryption standards.

The VSX 7000e makes it easy to get started by giving you the option of connecting either a VGA or TV display as your main display. For applications that require content sharing, connect both a TV (for People) and a VGA (for Content). The VSX 7000e is designed for maximum flexibility combined with easy installation and setup – allowing any user to quickly and easily configure their VSX 7000e system for immediate video conferencing.

The different connection options, all of which are plug-and-play, allow you to connect a VCR for record and playback, a second camera (document camera or another video source), and attach a PC to display content from the Web or from a local or network directory. Once these other video and content sources are connected, users can easily show a movie file, PowerPoint® presentation, pictures, live video feeds, as well as play audio files – all while participating in a video conference. And the other participants in the video conference can always see the people speaking as well as the content being shown, imitating the environment of everyone being in the same room.

In today's Internet driven world, the ability to conduct real time communication and collaboration has become critical to an organization's survival. As the market leader in voice, video, data and Web solutions, our award-winning conference technology makes it easy for people to interact and maximize productivity – over any network, in just about any environment, anywhere around the globe. That's why more organizations worldwide use and prefer Polycom conferencing solutions. Because when people work together, great things happen. To learn more, please visit the Polycom Experience Center at www.polycom.com/experience



Polycom VSX 7000e Specifications

ITU H.323 and H.320 compliant

VSX 7000e Bundled Packages:

- VSX 7400e Presenter: VSX 7000e, PowerCam, VGA encoder key, ImageShare II, People+Content IP
- VSX 7400e Presenter VTX: VSX 7400 Presenter with SoundStation VTX 1000 instead of microphone array
- VSX 7800e Presenter MP: VSX 7000e, PowerCam, VGA encoder key, ImageShare II, People+Content IP, 4-way MPPlus
- VSX 7800e Presenter MP VTX: VSX 7800e with SoundStation VTX 1000 instead of microphone array

Bandwidth

- Maximum Data Rate IP and Serial/V.35: Up to 2 Mbps
- Maximum Data Rate ISDN: Up to 2 Mbps

Video Standards & Protocols

- H.261, Annex D
- H.263+ Annexes: F, I, J, L, N, T
- H.263+ Annexes: W
- H.264
- ITU 60-fps full screen – Pro-Motion

Frame Rates (Point-to-Point)

- Intelligently selects frame rate for best performance video
- 30 fps at 56 kbps up to 2 Mbps
- 60 fields per second up to 2 Mbps

Video Inputs: 4 Connectors

- 1 x S-Video Main Camera or PowerCam™ PTZ control, IR, mic input
- 1 x S-Video; 4-pin mini DIN (second camera with PTZ control)
- 1 x S-Video; 4-pin mini DIN (VCR or DVD player)
- 1 x VGA (Content input from laptop)

Serial Data Port: 2 Connectors

- 2 x DB9
 - Control port for custom integration with remote devices such as Crestron® and AMX® control systems
 - Integration with Polycom Vortex® Installed Voice Products
 - Communication port for transmission of serial data (i.e. medical devices) over ISDN or IP calls
 - Auxiliary camera control

Video Outputs: 4 Connectors

- 1 x S-Video (main display)
- 1 x S-Video; 4-pin mini DIN (second display)
- 1 x S-Video; 4-pin mini DIN (VCR or DVD player)
- 1 x VGA (Main or content display)

Video Formats

- NTSC/PAL
- Graphics: XGA, SVGA, VGA

People Video Resolution

- Pro-Motion interlaced video (60/50 fields full-screen video for NTSC/PAL)
- 4CIF (704 x 480)
- 4CIF (704 x 576)
- SIF (352 x 240)
- CIF (352 x 288)
- Choice of 4:3 or 16:9 display aspect ratios

Content Video Resolution

- XGA (1024 x 768), SVGA (800 x 600), VGA (640 x 480) for or Content on 2nd VGA Displays (when used with primary NTSC/PAL display)
- People video support for 4CIF and 4SIF on second VGA display
- Single monitor graphics display (1024 X 768)
- Up to 4CIF for Content on NTSC/PAL displays

Audio Standards & Protocols

- Polycom Siren 14 StereoSurround
- 14 kHz bandwidth with Siren 14 on IP, ISDN, and IP/ISDN mixed calls
- 7 kHz bandwidth with G.722, G.722.1
- 3.4 kHz bandwidth with G.711, G.728, G.729A

Audio Features

- Seamless integration with Polycom Vortex Installed Voice Products

- Audio add-in using SoundStation VTX 1000 conference phone
- Audio add-in over ISDN
- Audio add-in over POTS
- Full-duplex digital audio
- Instant Adaptation Echo Cancellation
- Automatic Gain Control (AGC) – Voice activated
- Automatic Noise Suppression (ANS)
- Ability to turn off Echo Cancellation when external audio equipment is used
- Audio Mixer (Mic, VCR, line-in)
- Built-in tonal speaker test
- Real-time audio level meter for local and far-end microphones
- Microphone and VCR input audio mixing
- Ability to talk over VCR audio

Audio Inputs: 4 Connectors

- 1 x Conference link
 - Supports up to (3) microphones
 - Supports SoundStation VTX 1000 conference phone
- 2 x RCA/Phono, line level input for VCR, DVD player or audio mixer
- 2 x RCA stereo
- 1 x RJ-11 for analog speaker telephone

Audio Outputs: 4 Connectors

- 2 x RCA Phono connectors; balanced line level output
- 2 x RCA/Phono, Line Level output for VCR record
- 2 x RCA/Phono, Line Level output for speakers

Other ITU-Supported Standards

- H.221 communications
- H.224/H.281 far-end camera control
- Annex Q standard for FECC in H.323 calls
- H.225, H.245, H.241, H.331
- H.239 People+Content
- H.231 in multipoint calls
- H.243 MCU password
- H.233, H.234, H.235V3 encryption standards
- Bonding, Mode 1

Network Interfaces Supported

- IP (LAN, DSL, cable modem)
- Single 10/100 Ethernet port (10 bps/100Mbps/Auto)
- Optional ISDN QBR1 (Basic Rate Interface) Module
- Optional ISDN PRI (Primary Rate Interface) Module T1/E1
- Optional Serial Module (V.35/RS-530/RS-449 with RS-366 dialing)

Network Features

- SIP Support (Session Initiation Protocol)
- Integration with Cisco Systems® CallManager Version 4.0
- Down speeding over IP and ISDN
- Audio & Video Error Concealment over IP and ISDN, mixed calls
- IP address conflict warning
- Fast Connect IP for quick video connections
- Maximum call length digital timer
- Auto SPID detection and line number configuration
- MGC™ Click&View™ for individual screen layouts
- Polycom OneDial™ intelligent call management attempts call on preferred network (IP or ISDN) and automatically rolls over to secondary network if needed
- Polycom PathNavigator™ support for easy call placement and network cost optimization
- TCP/IP, UDP/IP, RTP, DNS, WINS, DHCP, ARP, HTTP, FTP, Telnet
- Chair control through API command or Integrated Web Interface
- Software Upgradeable Inverse Multiplexer (IMUX) Conference on Demand
- Initiates unscheduled MGC calls from the end-point
- Utilizes Polycom Office™ (PathNavigator & MGC)
- Auto selects either the internal or external bridge
- Dials all participants simultaneously

Security

- COMSEC tested by Titan Systems, Information Security Systems Division, and independently validated to operate with approved government encryption technologies
- KG-194/KIV-7 encryptor support with on screen and address book dialing
- Enhanced integration for independently certified, classified encryption devices
- Account validation number entry
- Secure password authentication
- Unique factory default passwords
- Administrator password
- Dial-in meeting password
- Encrypted password for VSX Web access
- Ability to disable remote interfaces (FTP, Telnet, HTTP, SNMP)
- Ability to disable mixed protocol multipoint calls
- Auto-Answer (On/Off)
- Allow access to user settings (On/Off)

Embedded Encryption

- Advanced Encryption Standard (AES)
- FIPS validated by National Institute of Standards & Technology (NIST) certified agency
- 128-bit key length
- AES software encryption on ISDN, IP and Serial/V.35 up to 2 Mbps
- Standards-based H.235V3 (IP)
- Standards-based H.233/H.234 (ISDN/Serial)
- Automatic key generation and exchange
- Supported in People+Content
- Supported in Point-to-Point IP, ISDN and mixed network calls

User Interface

- User-friendly graphical interface
- Customizable home screen and color themes
- Kiosk mode with scrolling marquee
- User-selectable camera icons and ring tones
- Up to (99) user defined camera presets
- Speed Dial List on home page
- Persistent Preview (Far-site PIP) on all screens
- Picture-In-Picture (PIP) (On/Off, Moveable)
- Dual-Monitor Emulation
- Numerical menu navigation (Similar to mobile phone)
- Date, Time Server accessibility
- Calendar and Conference scheduling
- Alert Signal on home page
- Do Not Disturb (On/Off)
- VSX Web for remote monitoring

Directory Services

- 4,000+ number global directory
- 1,000+ number local directory
- Speed dial list displaying video buddy list
- Limitless multipoint entries
- Live address book with Polycom Global Directory Services automatically and quickly updates directory with address changes or new endpoints
- Polycom Global Directory Services integrates with Active Directory/LDAP
- Directory Server backup in the event Polycom Global Directory is not accessible
- Automatic ISDN localization of calls

System Management

- SNMP for enterprise management
- Baseline mode setting for legacy system interoperability
- Diagnostics and software upgrades via PC, LAN
- Integrated VSX Web management tool
- Web Director: Remote administrator video monitoring and control from VSX Web (enabled/disabled from endpoint for security)
- Out-of-box setup from VSX Web
- Place a call from VSX Web
- Language independence between set-top interface and VSX Web
- System configuration from VSX Web
- Recent Calls Log – Records last 99 incoming and outgoing calls
- Call Detail Record (CDR) – Reports all incoming and outbound calls along with call statistics
- CDR Feature On/Off
- Downloadable CDR data for processing requires no external management system

- Account number validation at call initiation integrated with Polycom Global Management System™ for billing purposes
- Administrator-configurable dialing speeds
- Complete support for The Polycom Office including:
 - Polycom Global Management System
 - Polycom OneDial
 - Polycom PathNavigator
 - Polycom Conference Suite™
 - Polycom MGC
 - Polycom SoundStation VTX 1000
 - Polycom Vortex

Quality of Service and Experience – iPriority™

- Video Error Concealment
- Audio Error Concealment
- Universal Plug and Play (UPnP)
- IP Precedence (ToS)
- Configurable video/audio/FECC service value
- DiffServ (DSCP) (COS)
- RSVP
- Dynamic Bandwidth Allocation
- Proactive Network Monitoring
- Packet and jitter control
- Network Address Translation (NAT) support
- Automatic NAT discovery
- Asymmetric speed control
- Alternate Gatekeeper support
- TCP/UDP fixed-port firewall support
- Lip synchronization
- Echo cancellation
- Echo suppression
- Auto gatekeeper discovery
- Automatic gateway dialing profiles
- Specify outbound call routing for gateway/ISDN

Collaboration Solutions

- People and Content (PC, VCR/DVD, Doc cam) are always displayed simultaneously
- Direct VGA-in connectivity
- People+Content IP
- Show content from laptop/PC over IP network connection
- No resolution adjustment required on presenter's laptop/PC
- Supports CIF, SIF, 4CIF, 4SIF, VGA, SVGA, XGA display resolutions
- Zoom control
- Supports Windows® 2000 and Windows XP
- Adjustable bandwidth for content
 - 10% Content, 90% People
 - 50% Content, 50% People
 - 90% Content, 10% People
- Closed captioning support
- Web Streaming in and out of a call, RTP based, suitable with QuickTime® players

Language Support (13 languages)

- Chinese (Simplified), Chinese (Traditional), English (American), English (British), French, German, Italian, Japanese, Korean, Norwegian, Portuguese, Russian, Spanish
- Documentation translations in all languages
- User interface translations in all languages
- Keypad audio dialing confirmation in all languages
- VSX Web translations in all languages
- Remote controls labeled in all languages

Electrical

- Operating power supply
- Operating voltage/power 85-264 VAC, 47-63 Hz/ 72 Watts

Environmental Specifications

- Operating Temperature: 0-40° C
- Operating Humidity: 15-80%
- Non-Operating Temperature: -40-70° C
- Non-Operating Humidity (Non-condensing): 10-90%

Physical Characteristics

- Video Base Unit (W/H/D): 17.25"/1.73"/9.68"; 438.15 mm/43.83 mm/245.85 mm
- Video Base Unit Weight: 8.4 lbs; 3.8 kg

Warranty

- One-year return to factory parts and labor
- One-year software updates and upgrades

©2005 Polycom, Inc. All rights reserved.

Polycom, the Polycom logo, Vortex and SoundStation VTX 1000 are registered trademarks and VSX, StereoSurround, Pro-Motion, PowerCam, Siren, People+Content, MGC, Click&View, Polycom OneDial, Polycom PathNavigator, The Polycom Office, Global Management System, Polycom Conference Suite and iPriority are trademarks of Polycom, Inc. All other trademarks are the property of their respective owners. Information in this document is subject to change without notice.



Polycom Headquarters:

4750 Willow Road, Pleasanton, CA 94588 (T) 1.800.POLYCOM (765.9266) for North America only. For North America, Latin America and Caribbean (T) +1.925.924.6000, (F) +1.925.924.6100

Polycom EMEA:

270 Bath Road, Slough, Berkshire SL1 4DX (T) +44 (0)1753 723000, (F) +44 (0)1753 723010

Polycom Asia Pacific:

Polycom Hong Kong Ltd., Rm 1101 MassMutual Tower, 38 Gloucester Road, Wanchai, Hong Kong, (T) +852.2861.3113, (F) +852.2866.8028

Part No. 3726-17346-001 Rev. 10/05

Audiovisual Program

Page 105



DATA SHEET

Polycom® SoundStation® IP 7000 SIP-Based IP Conference Phone

Astounding voice quality and clarity from the world's most advanced IP conference phone

The SoundStation IP 7000 is a breakthrough conference phone that delivers outstanding performance and a robust feature set for SIP-based VoIP platforms. It is the most advanced conference phone ever developed, and is ideal for executive offices, conference rooms, and boardrooms.

The SoundStation IP 7000 features Polycom® HD Voice™ technology, boosting productivity and reducing listener fatigue by turning ordinary conference calls into crystal-clear interactive conversations. It delivers high-fidelity audio from 160 Hz to 22 kHz, capturing both the deeper lows and higher frequencies of the human voice for conference calls that sound as natural as being there.

For all conference calls, the SoundStation IP 7000 delivers advanced audio performance that far exceeds previous generations of conference phones. From full-duplex technology that eliminates distracting drop-outs to the latest echo cancellation advancements, only Polycom can deliver a conference phone experience with no compromises.

The SoundStation IP 7000 is the most flexible and expandable conference phone ever developed. Connect two units together for increased loudness and microphone pickup, as well as multiple call control interfaces in the conference room. Connect up to two optional expansion microphones to a single phone to ensure close proximity for everyone in the room. In addition, you can connect the SoundStation IP 7000 to the Polycom HDX® high-definition video conferencing system for a complete, integrated voice and video conferencing solution.

In the SoundStation IP 7000, Polycom has combined its rich history in voice conferencing and VoIP technology to develop a groundbreaking new conference phone that is the clear choice for SIP-enabled environments. It shares the same SIP phone software with Polycom's award-winning SoundPoint® IP products—the most comprehensive, reliable and feature-rich SIP products in the industry, with proven interoperability with a broad array of IP PBX and hosted platforms.

Plus, the SoundStation IP 7000 features a large multi-line high-resolution LCD display with a full XHTML microbrowser, turning your conference phone into a robust applications platform for your conference room. Bundled applications include advanced three-party conference features and LDAP corporate directory integration.



Benefits

- **Polycom HD Voice** – unparalleled clarity to make your conference calls more efficient and productive
- **Polycom's patented Acoustic Clarity Technology** – delivers the best conference phone experience with no compromises
- **Flexible configuration options** – multi-unit connectivity, expansion microphones and integration with Polycom HDX to meet the needs of many different types of rooms
- **Strong, robust SIP software** – leverages the most advanced SIP endpoint software in the industry, with advanced call handling, security, and provisioning features
- **Robust interoperability** – compatible with a broad array of SIP call platforms to maximize voice quality and feature availability while simplifying management and administration
- **Large high-resolution display with XHTML microbrowser** – enables new applications that make conference calling easier and more functional

Additional SoundStation IP 7000 features/benefits

- Equipped with built-in Power over Ethernet (PoE). An optional A/C power kit also available.
- 20-foot microphone pickup, and even more with optional expansion microphones or multi-unit connectivity, reaching all corners of the room.
- Automatic Gain Control intelligently adjusts the microphone sensitivity based on where participants are seated in the conference room.
- Features technology that resists interference from mobile phones and other wireless devices, delivering clear communications without distractions.
- Built-in 2.5mm applications port allows you to connect the conference phone to a mobile phone for productive calls even where no network connection is available, or to a computer for calls using PC-based soft phone clients.

Product specifications

Power

- IEEE 802.3af Power over Ethernet (built in)
- Optional external universal AC power supply:1
- 00-240V, 1.5A, 48V/50W

Display

- Size (pixels): 255 x 128 (W x H)
- White LED backlight with custom intensity control

Keypad

- Standard 12-key keypad
- Context-dependent soft keys: 4
- On-hook/Off-hook, redial, mute, volume up/down
- Directional navigation wheel

Audio features

- Loudspeaker
 - Frequency: 160-22,000 Hz
 - Volume: Adjustable to 88 dB at 1/2 meter peak volume
- Full-duplex: Type 1 compliant with IEEE 1329 full duplex standards
- Individual volume settings with visual feedback for each audio path
- Voice activity detection
- Comfort noise fill
- DTMF tone generation / DTMF event RTP payload
- Low-delay audio packet transmission
- Adaptive jitter buffers

- Packet loss concealment
- Acoustic echo cancellation
- Background noise suppression
- Supported Codecs
 - G.711 (A-law and Mu-law)
 - G.729a (Annex B)
 - G.722, G.722.1
 - G.722.1C
 - Siren 14
 - Siren 22
 - Call Handling Features
- Shared call / bridged line appearance
- Busy Lamp Field (BLF)
- Distinctive incoming call treatment / call waiting
- Call timer
- Call transfer, hold, divert (forward), pickup
- Called, calling, connected party information
- Local three-way conferencing
- One-touch speed dial, redial
- Call waiting
- Remote missed call notification
- Automatic off-hook call placement
- Do not disturb function

Other features

- Local feature-rich GUI
- Time and date display
- User-configurable contact directory and call history (missed, placed, and received)
- Customizable call progress tones
- Wave file support for call progress tones

- Unicode UTF-8 character support. Multilingual user interface encompassing Chinese, Danish, Dutch, English (Canada / US / UK), French, German, Italian, Japanese, Korean, Norwegian, Portuguese, Russian, Spanish, Swedish

Network and provisioning

- Ethernet 10/100 Base-T
- 2.5mm connection port
- USB ports: Mini and regular USB 1.1 (not active at launch)
- EX mic ports: Two Walta ports
- IP Address Configuration: DHCP and Static IP
- Time synchronization with SNTP server
- FTP / TFTP / HTTP / HTTPS server-based central provisioning for mass deployments. provisioning server redundancy supported.
- Web portal for individual unit configuration
- QoS Support – IEEE 802.1p/Q tagging (VLAN), Layer 3 TOS and DSCP
- Network Address Translation (NAT) support - static
- RTCP support (RFC 1889)
- Event logging
- Local digit map
- Hardware diagnostics
- Status and statistics
- User selectable ringer tones
- Convenient volume adjustment keys
- Field upgradeable

Security

- Transport Layer Security (TLS)
- Encrypted configuration files
- Digest authentication
- Password login
- Support for URL syntax with password for boot server
- HTTPS secure provisioning
- Support for signed software executables

Safety

- UL60950-1
- IEC60950-1
- EN60950-1
- CE Mark
- CSA C22.2, No. 60950-1-03
- AS/NZS60950-1

EMC

- FCC (47 CFR Part 15) Class A
- ICES-003 Class A
- EN55022 Class A
- CISPR22 Class A
- AS/NZS CISPR22 Class A
- VCCI Class A
- EN55024
- RoHS compliant

Protocol support

- IETF SIP (RFC 3261 and companion RFCs)t
- IEEE 802.3af Power over Ethernet version ships with
- Telephone Console
- 25 foot Ethernet cable
- Quick Start Guide
- Quick User Guide

AC Power version ships with

- Telephone Console
- 25 foot Ethernet cable
- Universal Power Supply
- 7 foot region-specific power cord
- Power Insertion Cable
- Quick Start Guide
- Quick User Guide

HDX Ready version ships with

- Telephone Console
- 25 foot Ethernet cable
- 15 foot C-link cable for connection to HDX
- Quick Start Guide
- Quick User Guide

Environmental conditions

- Operating temperature: 32 - 104 degrees F (0 - 40 degrees C)
- Relative humidity: 20%-85% (noncondensing)
- Storage temperature: -22 - 131 degrees F (-30 - 55 degrees C)

Warranty

- 1 year

Country of origin

- Thailand

Phone dimensions

- 15.5 x 14.6 x 2.9 in (39.4 x 37.2 x 7.3 cm) (L x W x H)

Phone console weight

- 2.4 lb (1.08 kg)

Box dimensions

- 19.1 x 17.0 x 5.1 (48.4 x 43.3 x 13 cm) (L x W x H)

Box weight

- 5.4 lb (2.43 kg)

Learn more

To find out how Polycom solutions can help your organization, visit us at www.polycom.com or speak with a Polycom Account Representative.

Need flexible financing?

Polycom **CAPITAL**
Collaborative Financing
www.polycom.com/polycom-capital

About Polycom

Polycom is the global leader in standards-based unified communications (UC) solutions for telepresence, video, and voice powered by the Polycom® RealPresence® Platform. The RealPresence Platform interoperates with the broadest range of business, mobile, and social applications and devices. More than 400,000 organizations trust Polycom solutions to collaborate and meet face-to-face from any location for more productive and effective engagement with colleagues, partners, customers, specialists, and prospects. Polycom, together with its broad partner ecosystem, provides customers with the best TCO, scalability, and security for video collaboration, whether on-premises, hosted, or cloud-delivered. Visit www.polycom.com or connect with Polycom on Twitter, Facebook, and LinkedIn.

Polycom, Inc.
1.800.POLYCOM
www.polycom.com

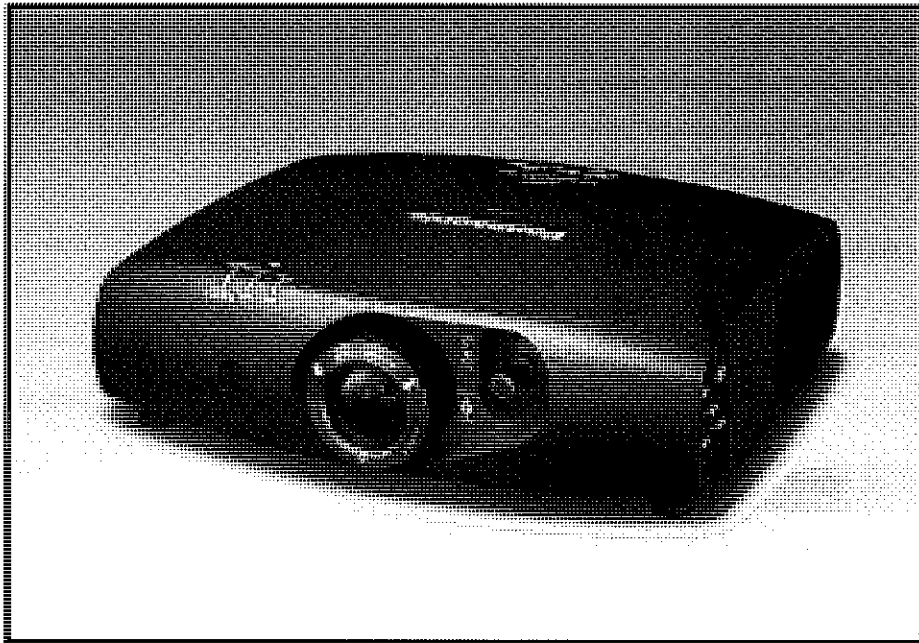
Polycom Asia Pacific Pte Ltd
+65 6389 9200
www.polycom.asia

Polycom EMEA
+44 (0)1753 723282
www.polycom.co.uk



**VIDEO PROJECTOR - SENIOR CENTER,
LOMBARDI BLDG, CITY HALL ANNEX,
PORTABLE SYSTEM**

S P E C F I L E



Product Number : PT-RZ470K/RZ470W

Product Name : DLP™ Projector

Specifications

Main unit

Power supply

100–240 V AC, 5.2–2.0 A, 50/60 Hz

Power consumption

460 W (470 VA)

(250 W*1 with LIGHT POWER set to NORMAL, 200 W*1 with LIGHT POWER set to Ecosave1, 178 W*1 with LIGHT POWER set to Ecosave2. 0.5 W with STANDBY MODE set to ECO*2, 8 W with STANDBY MODE set to NORMAL)

DLP™ chip

Panel size

16.5 mm (0.65 in) diagonal (16:9 aspect ratio)

Display method

DLP™ chip × 1, DLP™ system

Pixels

2,073,600 (1,920 × 1,080) × 1, total of 2,073,600 pixels

Lens

Manual zoom (2.0×), manual focus, F 2.0–3.4, f 21.5–43.0 mm

Throw ratio

1.46–2.94:1

Light source

LED/laser-combined (R, B: LED; G: laser diode)

Screen size

1.02–7.62 m (40–300 inches) diagonally, 16:9 aspect ratio

Brightness*3

3,500 lumens

Center-to-corner uniformity*3

90%

Contrast*3

20,000:1 (full on/off)

Resolution

1,920 × 1,080 pixels (Input signals that exceed this resolution will be converted to 1,920 × 1,080 pixels.)

Scanning frequency

HDMI/DVI-I (digital)

fH: 27–100 kHz, fV: 24–120 Hz, dot clock: 25–162 MHz

DVI-I (analog)/RGB

fH: 15–100 kHz, fV: 24–120 Hz, dot clock: 162 MHz or lower

YPbPr (YCbCr)

480i (525i): fH 15.75 kHz; fV 60 Hz,

576i (625i): fH 15.63 kHz; fV 50 Hz,

480p (525p): fH 31.50 kHz; fV 60 Hz,

576p (625p): fH 31.25 kHz; fV 50 Hz,

720 (750)/60p: fH 45.00 kHz; fV 60 Hz,

720 (750)/50p: fH 37.50 kHz; fV 50 Hz,

1035 (1125)/60i: fH 33.75 kHz; fV 60 Hz,

1080 (1125)/60i: fH 33.75 kHz; fV 60 Hz,

1080 (1125)/50i: fH 28.13 kHz; fV 50 Hz,

1080 (1125)/25p: fH 28.13 kHz; fV 25 Hz,

1080 (1125)/24p: fH 27.00 kHz; fV 24 Hz,

1080 (1125)/24sF: fH 27.00 kHz; fV 48 Hz,

1080 (1125)/30p: fH 33.75 kHz; fV 30 Hz,

1080 (1125)/60p: fH 67.50 kHz; fV 60 Hz,

1080 (1125)/50p: fH 56.25 kHz; fV 50 Hz

Video

fH: 15.75 kHz, fV: 60 Hz [NTSC/NTSC4.43/PAL-M/PAL60]

fH: 15.63 kHz, fV: 50 Hz [PAL/PAL-N/SECAM]

Optical axis shift

Vertical: +73%, -48% (manual), horizontal: +27%, -35% (manual)

Keystone correction range

Vertical: ±40°

Installation

Ceiling/floor, front/rear

Terminals

HDMI IN

HDMI 19-pin × 1, HDCP compatible, Deep Color compatible

480p (525p), 576p (625p), 720 (750)/60p, 720 (750)/50p, 1080

(1125)/60i, 1080 (1125)/50i, 1080 (1125)/25p, 1080 (1125)/24p, 1080

(1125)/24sF, 1080 (1125)/30p, 1080 (1125)/60p, 1080 (1125)/50p,

VGA (640 × 480)–WUXGA** (1,920 × 1,200), compatible with non-

interlaced signals only, dot clock: 25–162 MHz, audio signal: linear

PCM (sampling frequencies: 48 kHz, 44.1 kHz, 32 kHz)

DVI-I IN

DVI-I 29-pin × 1

Digital

DVI 1.0 compliant, HDCP compatible, for single link only

480p, 576p, 720/60p, 720/50p, 1080/60i, 1080/50i, 1080/24p,

1080/24sF, 1080/25p, 1080/30p, 1080/60p, 1080/50p,

VGA (640 × 480)–WUXGA** (1,920 × 1,200), compatible with non-

interlaced signals only, dot clock: 25–162 MHz

R, G, B

R: 0.7 Vp-p, 75 ohms,

G: 0.7 Vp-p (G: 1.0 Vp-p for sync on G), 75 ohms,

B: 0.7 Vp-p, 75 ohms

HD/VD, SYNC: TTL, high impedance, positive/negative automatic

NOTE: HD/SYNG, and VD terminals do not accept tri-level sync signals.

Y, Pb, Pr (Y, Cb, Cr) Y: 1.0 Vp-p (including sync signal), Pb/Pr (Cb/Cr): 0.7 Vp-p, 75 ohms

<p>COMPUTER (RGB) IN R, G, B</p>	<p>D-sub HD 15-pin (female) x 1 R: 0.7 Vp-p, 75 ohms, G: 0.7 Vp-p (G: 1.0 Vp-p for sync on G), 75 ohms, B: 0.7 Vp-p, 75 ohms HD/VD, SYNC: TTL, high impedance, positive/negative automatic NOTE: HD/SYNC, and VD terminals do not accept tri-level sync signals.</p>
<p>Y, PB, PR (Y, CB, CR)</p>	<p>Y: 1.0 Vp-p (including sync signal), Pb/Pr (Cb/Cr): 0.7 Vp-p, 75 ohms</p>
<p>VIDEO IN</p>	<p>RCA pin x 1, 1.0 Vp-p, 75 ohms</p>
<p>AUDIO IN</p>	<p>M3 (L, R) x 1, 0.5 Vrms</p>
<p>AUDIO OUT</p>	<p>M3 (L, R) x 1 (monitor out: 0–1.8 Vrms, variable)</p>
<p>SERIAL IN</p>	<p>D-sub 9-pin (female) x 1 for external control (RS-232C compliant)</p>
<p>LAN / DIGITAL LINK</p>	<p>RJ-45 x 1 for network and DIGITAL LINK (video/audio/network/serial control) connection, 100Base-TX, compatible with PLink™, HDCP compatible, Deep Color compatible, 480p (525p), 576p (625p), 720 (750)/60p, 720 (750)/50p, 1080 (1125)/60i, 1080 (1125)/50i, 1080 (1125)/25p, 1080 (1125)/24p, 1080 (1125)/24sF, 1080 (1125)/30p, 1080 (1125)/60p, 1080 (1125)/50p, VGA (640 x 480)–WUXGA** (1,920 x 1,200), compatible with non-interlaced signals only, dot clock: 25–162 MHz</p>
<p>3D SYNC OUT</p>	<p>Mini DIN 3-pin x 1, for 3D transmitter connection</p>
<p>Power cord length</p>	<p>3.0 m (9 ft 10 in)</p>
<p>Cabinet materials</p>	<p>Molded plastic</p>
<p>Dimensions (W x H x D)</p>	<p>455 x 137** x 415 mm (17-29/32 x 5-13/32** x 16-11/32 inches) (lens included)</p>
<p>Weight**</p>	<p>Approx. 11.0 kg (24.3 lbs)</p>
<p>Operation noise**</p>	<p>35 dB (LIGHT SOURCE MODE: NORMAL), 29 dB (LIGHT SOURCE MODE: LOW)</p>
<p>Operating temperature</p>	<p>0–45 °C (32–113 °F)**</p>
<p>Operating humidity</p>	<p>20%–80% (no condensation)</p>
<p>Wireless remote control unit</p>	
<p>Power supply</p>	<p>3 V DC (R6/LR6/AA type battery x 2)</p>
<p>Operation range**</p>	<p>Approx. 15 m (49 ft 3 in) when operated from directly in front of the signal receptor</p>
<p>Dimensions (W x H x D)</p>	<p>48 x 163 x 24.5 mm (1-13/32 x 6-5/8 x 31/32 inches)</p>
<p>Weight</p>	<p>Approx. 117 g (4.1 oz) (including batteries)</p>
<p>Supplied accessories</p>	
	<p>Power cord with security lock (x 1) (Power cord x 2 for PT-RZ470EA) Wireless remote control unit (x 1) Batteries for remote control (R6/LR6/AA type x 2) Software CD-ROM (Logo Transfer Software, Multi Projector Monitoring & Control Software) (x 1)</p>
<p>Optional accessories</p>	
<p>Digital interface box</p>	<p>ET-YFB100G</p>
<p>Ceiling mount bracket</p>	<p>ET-PKR100H (for high ceilings) ET-PKR100S (for low ceilings)</p>
<p>Portrait mode mount bracket</p>	<p>ET-PKR100P</p>

Weights and dimensions shown are approximate. Specifications and appearance are subject to change without notice.

*1 In STANDARD/GRAPHIC picture mode. Measured based on the power consumption rate and a measurement method for the TV receiver.

*2 When the STANDBY MODE is set to ECO, network functions such as power on over the LAN network will not operate. Also, only certain commands can be received for external control using the serial terminal.

*3 Measurement, measuring conditions, and method of notation all comply with ISO 21118 International standards.

*4 WUXGA resolution is supported only when the signals are compliant with VESA CVT-RB (Coordinated Video Timing-Reduced Blanking).

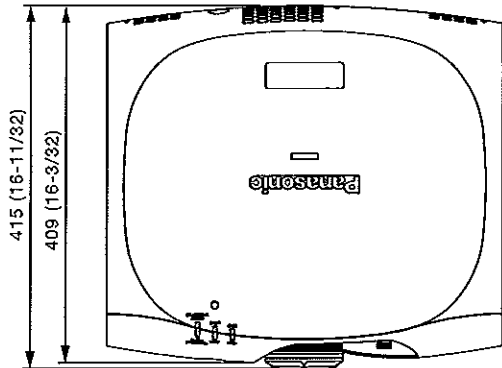
*5 With legs at shortest position.

*6 Average value. May differ depending on the actual unit.

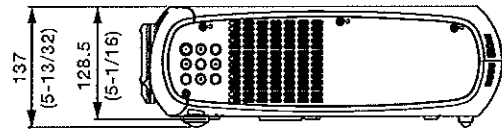
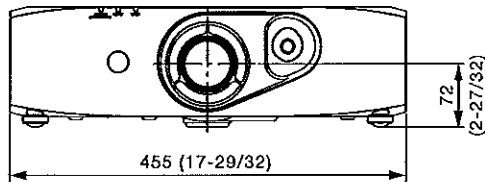
*7 0–40 °C (32–104 °F) between 1,400 m and 2,700 m (4,593 ft and 8,858 ft) above sea level. If the ambient temperature exceeds 35 °C (95 °F), the light output may be reduced to protect the projector.

*8 Operation range differs depending on environments.

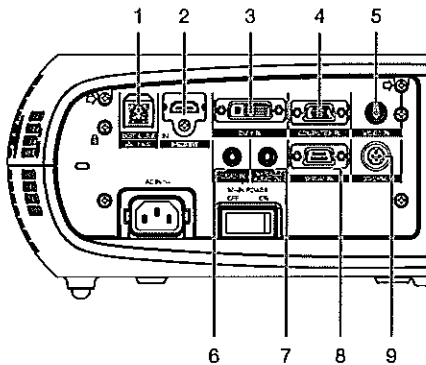
Dimensions



unit : mm (Inch)
NOTE: This illustration is not drawn to scale.



Terminals



- 1 LAN / DIGITAL LINK connector
- 2 HDMI input
- 3 DVI-I input
- 4 Computer input
- 5 Video input
- 6 Audio input
- 7 Audio output
- 8 Serial input
- 9 3D SYNC output



SOLID SHINE Series projectors provide **solid reliability** and **long-lasting brightness** unprecedented by conventional lamp-based projectors.

The Benefits of the LED/Laser-Combined Light Source

✓ **Approximately 20,000 hours* of maintenance-free operation**

No need to replace the light source or air filter, providing a dramatic reduction in TCO.

✓ **Long-lasting picture quality**

Excellent picture quality and brightness are maintained for a long time.

✓ **Superb color reproduction**

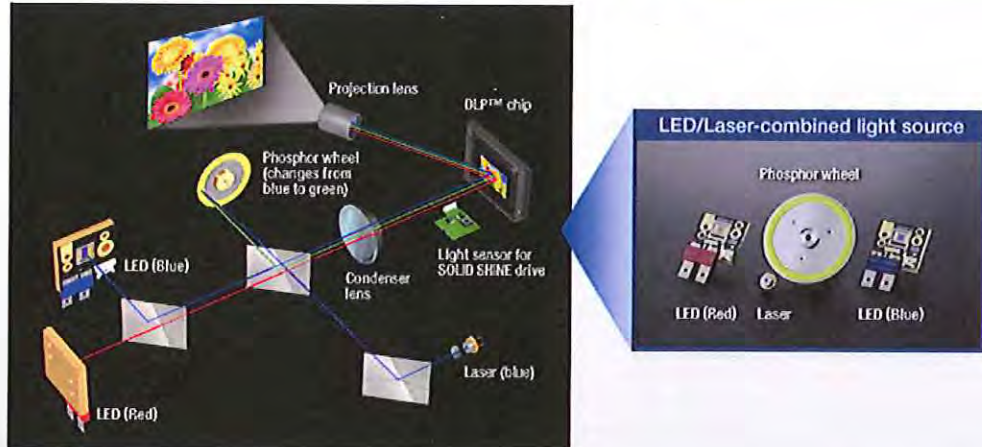
Beautiful, vivid colors exceeding the levels of conventional projectors.

✓ **Quick start, quick off**

The image appears almost instantly upon powering up, and there is no need for cooling after turning the power off.

The power can be turned on immediately after being turned off, and it can be turned on/off as many times as you want.

PT-RZ470/RW430 Optical Structure Image



The LED/Laser-Combined Light Source Enables Approx. 20,000* Hours of Continuous Operation

This new light source requires no maintenance for approximately 20,000 hours.* In many cases, this means no maintenance until your next refresh cycle. Naturally, there are no lamp burnout problems during use, so reliability is further increased. There is also no filter to clean due to carefully engineered sealed optics.

As a consequence, running cost is dramatically lowered because of the savings on lamp costs, maintenance labor and hassle of stocking lamps.

* A guideline for light source replacement. The maintenance-free period may be shortened due to environmental conditions.



Bright, Beautiful Picture Quality for a Long Period of Time

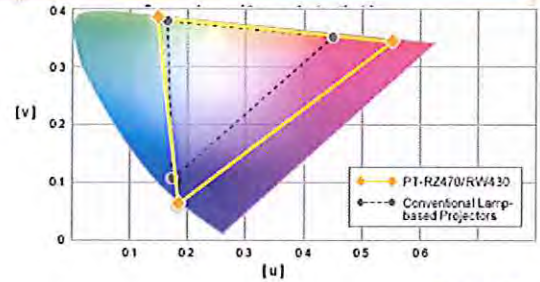
The PT-RZ470/RW430 features 3,500 lumens of brightness. Rate of brightness deterioration in the LED/Laser-combined light source is extremely slow compared to lamp-based projectors. The SOLID SHINE drive uses a built-in sensor to constantly detect the light intensity of the light source and correct corresponding changes in white balance. This all helps to maintain excellent picture quality for a long period of time.



Excellent Picture Quality for a Long Period of Time

Superior Color Reproduction

The LED/Laser-combined light source has a higher level of color purity than an ordinary lamp, allowing it to achieve color reproduction with wider color space. Colors are more vibrant than those of conventional projectors.



[Return to Top](#)

30x Drive* Switching Prevents Color Breaking

In 1-chip DLP™ system projectors with conventional lamp, a color wheel is used for time-division multiplexing in a method where the human eye combines the result to achieve a full-color palette. In the PT-RZ470/RW430, this is done by on/off switching of the LED/Laser-combined light source. A unique Panasonic power supply circuit provides time-division multiplexing with ultrafast 30x drive.* The resulting, high-definition images exhibit virtually no color breaking.**

* Picture mode: Dynamic. 10x drive in other picture modes.
 The rate for each vertical sync/blanking interval, with R/G/B light source switching set to 1x.
 ** A condition in which incorrect color expression causes color flickering.

Heat Pipe Cooling System Maintains Stable Operation up to 45 °C (113 °F)*

Laser cooling is performed by releasing the heat to cooling fins, then cooling with a heat pipe cooling system. This suppresses temperature rises inside the projector and allows stable operation up to an ambient temperature of 45 °C (113 °F).*

The use of this heat-pipe cooling system also achieves quiet operation of 29 dB,** enabling viewers to concentrate on the presentation or on quiet movie scenes.

* The operating temperature range is 0 °C to 40 °C (32 °F to 104 °F) when used in locations from 1,400 m to 2,700 m (4,593 ft to 8,858 ft) above sea level. If the ambient temperature exceeds 35 °C (95 °F), the light output may be reduced to protect the projector.
 ** LIGHT POWER mode: ECO. 35 dB with LIGHT POWER mode set to NORMAL.



Dust-Resistant Structure with an Airtight Optical Block

The area between the LED/Laser to the DLP™ chip and prism is hermetically sealed to form an airtight structure for the optical block, the heart of the projector. This resists the effects of dust and other particles in the air, and enables use of the projector in a wide range of environments.

The Daylight View Basic Ensures Clear Images Even in Brightly Lit Rooms

Panasonic's Daylight View Basic technology achieves sharp, easy-to-see images by clearly reproducing the details in dark image areas, which were previously difficult to see in brightly lit rooms. A built-in sensor measures the ambient light, and the Daylight View Basic function adjusts the halftone color and brightness level according to the surrounding illumination.

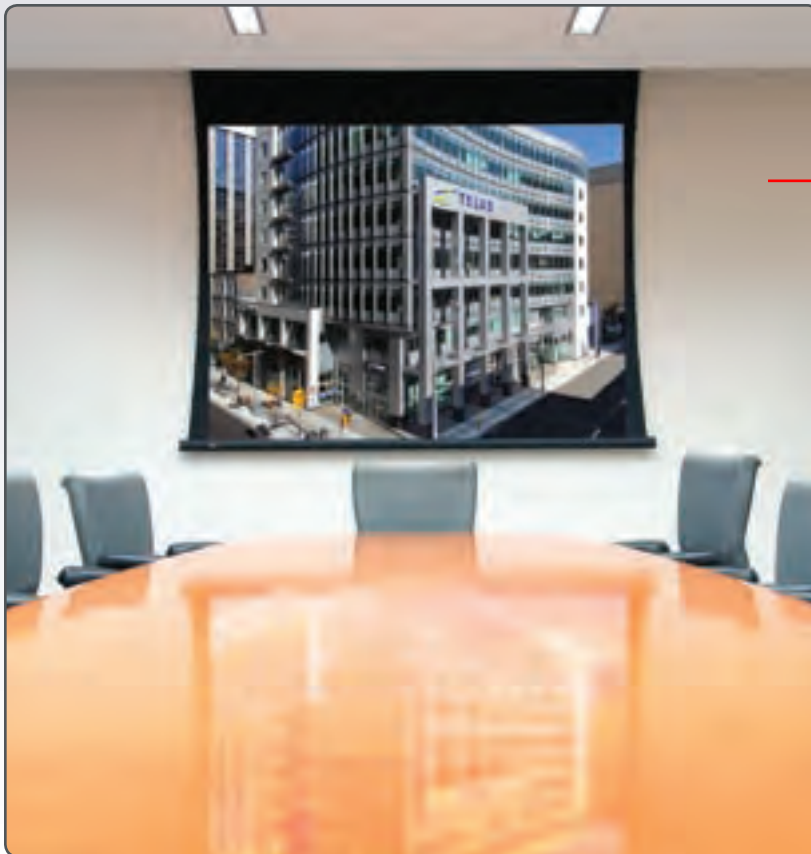


DICOM Simulation Mode*

ACCESS SERIES



ELIMINATES YOUR INSTALLATION PROBLEMS—
INSTALL THE CASE NOW / SCREEN LATER



Telus House conference room—Ottawa, Ontario. LEED® Silver Certified.
Photography © Ron de Vries—Toronto, Ontario



Access Screen up



Access Screen down

FEATURES

- The Access Series screens feature ceiling trim flanges, prewired junction box, and movable brackets for a smooth installation.
- The extruded aluminum case is UL approved for use in environmental air space.
- Case can be installed in advance of screen: see page 6.

➔ **Access/Series V**—Motorized screen available with the unparalleled performance of our Tab Tensioning System in M1300, M2500 and HiDef Grey front projection surfaces, as well as the Cineflex rear projection surface. See page 10 for more on the benefits of Tab Tensioning.

Access/Series E—Motorized screen with your choice of a conventional viewing surface: Matt White, Glass Beaded, High Contrast Grey or acoustically transparent AT1200 or AT Grey.

OPTIONS

- **Extra Drop**—Additional drop is optional, either white or black. (White is standard for Series E in AV format. Black is standard for Series E in all other formats and for all Series V screens).
- **Black Masking Borders**—Borders are optional for Series E in AV format. Borders are standard for Series E in all other formats and for all Series V screens.
- **Motor and Control Options**—Refer to page 6. Controls may be built into case and will increase overall length of case. Available with optional Quiet Motors, Motors with Built-In Low Voltage Controller, or Quiet Motors with Built-In Low Voltage Controller.

SIZES AND FORMATS

Audio Visual Format

from 50"x50" to 12'x12'

NTSC Format

from 6' to 200" diagonal

HDTV Format

from 92" to 184" diagonal

16:10 Format

from 94" to 189" diagonal

WideScreen Format

from 99" to 182" diagonal

Custom Sizes Available

Full details available at:

www.draperinc.com/go/AccessV.htm

www.draperinc.com/go/AccessE.htm

U.S. Patent Nos. 6,137,629; 6,421,175 and 6,532,109;
Other patents pending.



EON515

Portable Self-Powered 15",
Two-Way, Bass-Reflex Design

Professional Series

Applications:

- ▶ Live sound reinforcement, speech and vocals, music playback in entertainment, A/V, and institutional venues – especially when ease of use and portability are important factors.
- ▶ Amplification, mixing, and monitoring for electronic musical instruments.
- ▶ Everywhere you need to be heard.

Features:

- ▶ 450 watt High-Performance Powered Speaker System
- ▶ True portability weighing only 14.8 kg (32.5 lb)
- ▶ Multiple handles with comfort rubber grips for easy transport
- ▶ 15" Differential Drive® low-frequency driver with neodymium magnet for low-distortion and light weight
- ▶ 1" throat diameter next generation JBL neodymium compression driver
- ▶ Efficient Crown® Class-D amplifier technology
- ▶ Built-in 3 Channel Mixer
- ▶ 100° H x 60° V asymmetrical wave guide for uniform audience coverage
- ▶ Line level and direct microphone input capability
- ▶ Selectable Pre-engineered EQ settings
- ▶ Unique Mix/Loop signal flow function for extended system application
- ▶ Easy “daisy-chain” connections for extending the system
- ▶ Integrated M10 suspension points for easy rigging
- ▶ Multi angle enclosure for main or monitor applications
- ▶ Integrated 36 mm pole mount socket with stabilizing securing screw
- ▶ Highly designed composite enclosures for durability, lightweight, and acoustic performance

The EON515 is a 15-inch, two-way, powered, portable speaker system. Capable of reproducing full bandwidth sound at high levels it offers the additional utility of a 3 channel built-in mixer. The EON515 is comprised of a 380 mm (15 in) Differential Drive® woofer, a 25.4 mm (1 in) neodymium high frequency compression driver coupled to a 100° H by 60° V waveguide. Both components are driven by the discrete channels of a 450 watt Crown® Class-D integrated power amplifier. The input section contains all cross-over functions, protection, and mixer functionality.

The mixer offers XLR or ¼-inch TRS phone jack compatibility. Selectable input sensitivities allow a broad range of devices to be properly matched. A unique mix/loop signal flow router provides opportunities for daisy chaining or rigging with the built-in mixer only. Pre-engineered system EQs allow for matching the settings to the actual source material. In the “cut” position maximum level can be achieved for speech reproduction by reducing need to reinforce the lower frequencies. This is also a typical setting when using the system as a floor monitor, reducing low frequency build-up which occurs naturally when placed on a floor. The “flat” setting is ideal for live music and the “boost” for reproducing low level pre-recorded music, delivering extra low and high frequency energy. The signal present and limit lights indicate performance status. An additional switch is provided to defeat the illuminated logo in theatre applications.



In addition to acoustic performance the EON515 features three full size deep-well handles, light weight, and balanced ergonomics. The new generation of EON products offers true portability and ease of handling. Five standard M10 rigging points and integrated pole mount socket increase the system's utility. The extremely rugged copolymer enclosure has been designed for main and 45° monitor orientation in the left and right hand configuration. A full screen-backed steel grille offers additional protection for both the woofer and compression driver components.

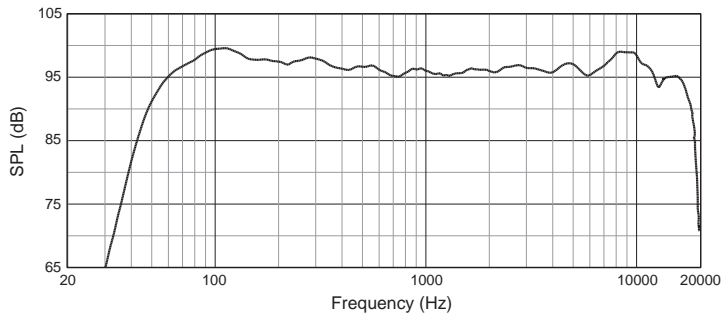
Specifications:

System Type:	Self powered 15", two-way, bass-reflex design
Frequency Range (-10 dB):	39 Hz -20 kHz (EQ in 'Flat' position)
Frequency Response (±3 dB):	42 Hz - 18 kHz (EQ in 'Flat' position)
Coverage Pattern:	100° H x 60° V nominal
Directivity Index (DI):	9 dB
Directivity Factor (Q):	8
Crossover Frequency:	2.2 kHz
System Power Rating:	450 W continuous, 900 W peak
LF Power amp:	350 W continuous at driver impedance
HF Power amp:	100 W continuous at driver impedance
Distortion:	Less than 0.1% at rated power
Maximum SPL:	129 dB
Signal indicators:	Limit: Red LED indicates input overload condition Signal: Green LED indicates signal present Mic/Line: Red LED indicator
Input Gain (input 3):	Mic position: -Infinity to +40 dB Line position: -Infinity to +4 dB (+20 dBu Max signal input)
Input Gain (input 1 & 2):	-Infinity to +4 dB (+20 dBu Max signal input)
Input Impedance:	64 K Ohms (balanced), 32 K Ohms (unbalanced)
Boost EQ:	LF +3 dB Shelving Filter @ 200 Hz HF +2.5 dB Shelving Filter @ 4 kHz
Low Cut Filter:	Preset high pass @ 120 Hz
LF Driver:	1 x JBL 265F-1 380 mm (15 in) Differential Drive® integrated woofer with dual 2" voice coils
HF Driver:	1 x JBL 2414H 25.4 mm (1 in) neodymium compression driver
Input 3 connector:	Balanced XLR / ¼ inch TRS combo jack with XLR loop through
Input 1 & 2 connectors:	Balanced ¼ inch TRS jack
Output (Loop/Mix switch):	Balanced male XLR, +20 dBu (peak) o/p level in MIX position
XLR Pin Assignments:	Pin 2 (+), Pin 3 (-), Pin 1 (GND)
Limiting/Protection:	Dynamic Limiter
Enclosure:	PP impact copolymer, multi-purpose main & monitor orientation.
Handles:	One left/right side, one on top, with rubber grip
Suspension / Mounting:	36 mm pole socket with stabilizing screw, 4 x M10 suspension points, 1 x M10 pull-back point
Grille:	Powder coated perforated steel with acoustically transparent black screen backing.
AC input:	120 – 240 V, 50/60 Hz
Dimensions (H x W x D):	685 x 438 x 366 mm (27.0 in x 17.3 in x 14.4 in)
Net Weight:	14.8 kg (32.5 lb)

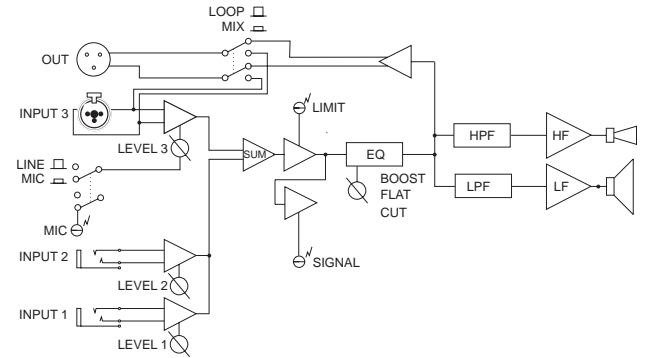
JBL continually engages in research related to product improvement. Some materials, production methods and design refinements are introduced into existing products without notice as a routine expression of that philosophy. For this reason, any current JBL product may differ in some respect from its published description, but will always equal or exceed the original design specifications unless otherwise stated.

▶ EON515 Portable Self-Powered 15", Two-Way, Bass-Reflex Design

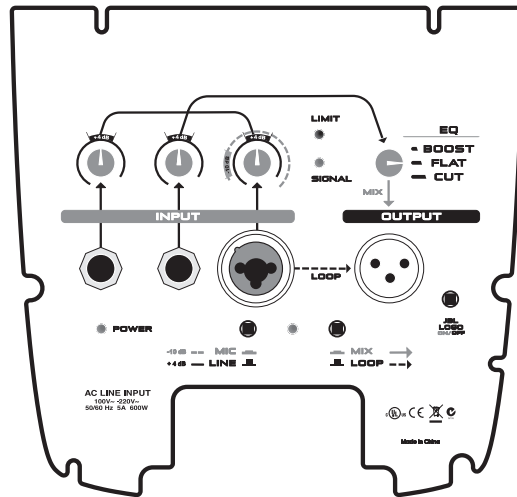
On Axis Frequency Response



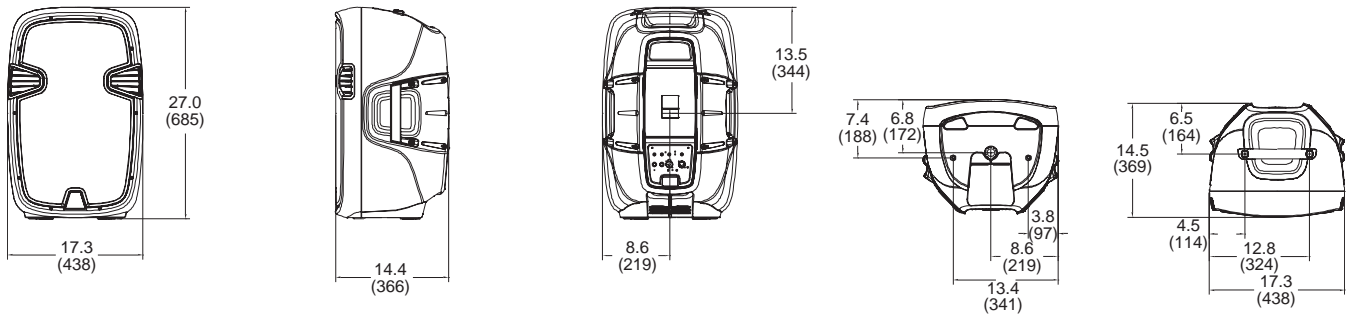
Block Diagram



Input Panel



Dimensions



Dimensions in inches (in)



JBL Professional
8500 Balboa Boulevard, P.O. Box 2200
Northridge, California 91329 U.S.A.

A Harman International Company
© Copyright 2008 JBL Professional
www.jblpro.com

FAST-FOLD® DELUXE PROJECTION SCREENS



- Fast-Fold® Deluxe frame and legs are constructed of sturdy 1 1/4" aluminum tubing and feature easy release latches for simple, quick set up and tear down of the screen.
- Black anodized frame option is available.
- All viewing surfaces up to 16' high will be seamless.
- Complete screen also includes a rugged carrying case with wheels.
- Da-Mat® fabric is standard with a foldable black backing, which allows for the portability of a Fast-Fold® screen with the superior image quality and opacity of a black backed material.

Available Screen Surfaces: Da-Mat®, Da-Tex® (rear), High Contrast Da-Tex® (rear), Dual Vision, Ultra Wide Angle (rear) and 3D Virtual Black® (rear).

See pages 6-10 for surface descriptions.

4:3 VIDEO FORMAT DIMENSIONS

Overall Frame Size H x W		Viewing Area* H x W	
ft./in.	cm	in.	cm
54" x 74"	137 x 188	50" x 70"	127 x 178
63" x 84"	160 x 213	59" x 80"	150 x 203
6' x 8'	183 x 244	68" x 92"	173 x 234
7'6" x 10'	229 x 305	86" x 116"	218 x 295
9' x 12'	274 x 366	104" x 140"	264 x 356
10'6" x 14'	320 x 427	122" x 164"	310 x 417

16:9 HDTV FORMAT DIMENSIONS

Overall Frame Size H x W		Viewing Area* H x W	
ft./in.	cm	in.	cm
56" x 96"	142 x 244	52" x 92"	132 x 234
62" x 108"	157 x 274	58" x 104"	147 x 264
69" x 120"	175 x 305	65" x 116"	165 x 295
83" x 144"	211 x 366	79" x 140"	201 x 356
8' x 14'	244 x 427	92" x 164"	234 x 417

16:10 WIDE FORMAT DIMENSIONS

Overall Frame Size H x W		Viewing Area* H x W	
in.	cm	in.	cm
62" x 96"	157 x 244	58" x 92"	147 x 234
69" x 108"	175 x 274	65" x 104"	165 x 264
77" x 120"	196 x 305	73" x 116"	185 x 295
92" x 144"	234 x 366	88" x 140"	224 x 356

SQUARE FORMAT DIMENSIONS

Overall Frame Size H x W		Viewing Area* H x W	
ft./in.	cm	in.	cm
54" x 54"	137 x 137	50" x 50"	127 x 127
72" x 72"	183 x 183	68" x 68"	173 x 173
7' x 7'	213 x 213	80" x 80"	203 x 203
8' x 8'	244 x 244	92" x 92"	234 x 234
9' x 9'	274 x 274	104" x 104"	264 x 264
10' x 10'	305 x 305	116" x 116"	295 x 295
12' x 12'	366 x 366	140" x 140"	356 x 356

*Heavy duty HD-Legs recommended for added stability.

*Da-Tex®, High Contrast Da-Tex®, Dual Vision, Ultra Wide Angle and 3D Virtual Black® net picture area is 1/2" x 1/2" smaller than size listed.

Masking panels available. See page 125.



Shap-Latch Hinge on frame and legs allows for easy set up and tear down.



Retractable corner brace closes within frame tubing for additional strength.



Durable wheeled poly case with built-in handles and Speedy Crank storage compartment.



ULX® Wireless Systems

TAKE CONTROL.

Wireless applications of increased complexity and scale require powerful solutions. Experienced audio engineers and sound contractors rely on Shure ULX® wireless systems to achieve clear, hassle-free wireless sound. An ultra-wide tuning range with up to 40 compatible systems* guarantees confident command of demanding installations and live sound productions.

Bulletproof wireless performance.

Ultra-wide 36 MHz bandwidth and automatic frequency selection ensures consistent operation across multiple TV channels with no setup hassles.

Superior sound quality.

Shure's patented Audio Reference Companding delivers crystal-clear audio transmission.

Intuitive operation.

Advanced front panel controls and the large multi-function LCD allow for quick monitoring of system status.



ULXP4 Wireless Diversity Receiver

- Up to 1400 selectable frequencies
- Automatic Frequency Selection with group scan function
- Predictive Diversity
- 5-segment audio meter
- 5-segment RF meter
- Advanced multi-function LCD

















- 3-segment transmitter battery fuel gauge
- Squelch adjustment
- ½ rack design
- Remotable ½ wave antennas
- Frequency and volume lockout
- Rugged metal chassis
- Furnished rack hardware
- Locking DC connector
- XLR and ¼" outputs

Handheld or Bodypack Transmitter

- 3-segment battery fuel gauge
- Backlit LCD shows group and channel
- Frequency and power lockout
- 8 hour battery life
- 100m (300 ft.) operating range
- 20dB pad switch on ULX1

* Location dependent

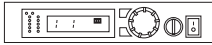
ULX® Wireless Systems

<p>Systems include: ULXP4 Diversity Receiver and a choice of Handheld Microphone Transmitter.</p>	<h2>HANDHELD</h2>				
<p>Systems include: ULXP4 Diversity Receiver, ULX1 Bodypack Transmitter and a choice of Microphone or Guitar/Bass Cable.</p>	<h2>LAVALIER</h2>				
<p>Systems include: ULXP4 Diversity Receiver, ULX1 Bodypack Transmitter and ULX2 Handheld Transmitter.</p>	<h2>COMBO</h2>				
<p>Systems include: (2) ULXP4 Diversity Receivers and (2) Transmitters.</p>	<h2>DUAL</h2>				
<p>Systems include: (2) ULXP4 Diversity Receivers, a ULX1 Bodypack Transmitter and a choice of Handheld Transmitter(s).</p>	<h2>DUAL COMBO</h2>				
<div style="display: flex; justify-content: space-between;"> <div data-bbox="298 218 509 401">  <p>SM58® The legendary choice of vocal performers around the globe. ULXP24/58</p> </div> <div data-bbox="509 218 721 401">  <p>SM86 Tailored frequency response for clear reproduction of vocals. ULXP24/SM86</p> </div> <div data-bbox="721 218 932 401">  <p>SM87A Smooth sound tailored for warm, accurate reproduction. ULXP24/87</p> </div> <div data-bbox="932 218 1143 401">  <p>Beta 58A® Preferred by touring vocalists and sound professionals. ULXP24/BETA58</p> </div> <div data-bbox="1143 218 1354 401">  <p>Beta 87A Brings exceptional clarity to live vocals. ULXP24/BETA87A</p> </div> <div data-bbox="1354 218 1565 401">  <p>Beta 87C Adds warmth to the frequency response preferred by in-ear users. ULXP24/BETA87C</p> </div> </div>	<div style="display: flex; justify-content: space-between;"> <div data-bbox="342 491 537 709">  <p>WL183 Premium condenser lavalier mic for speech applications. Omnidirectional ULXP14/83</p> </div> <div data-bbox="558 491 753 709">  <p>WL184 Premium condenser lavalier mic for speech applications. Supercardioid ULXP14/84</p> </div> <div data-bbox="774 491 969 709">  <p>WL185 Premium condenser lavalier mic for speech applications. Cardioid ULXP14/85</p> </div> <div data-bbox="990 491 1185 756">  <p>WL50 Subminiature Omnidirectional lavalier mic provides low visibility with professional audio quality. ULXP14/50</p> </div> <div data-bbox="1206 491 1401 730">  <p>WL51 Subminiature Cardioid lavalier mic provides low visibility with professional audio quality. Less susceptible to feedback. ULXP14/51</p> </div> </div>	<div style="display: flex; justify-content: space-between;"> <div data-bbox="342 785 537 1142"> <h3>HEADWORN</h3>  <p>WH30TQG Rugged, comfortable headset that provides high-quality voice pickup for active vocalists. ULXP14/30</p> </div> <div data-bbox="558 785 753 1142">  <p>WBH53 Beta quality, sensitivity and consistency in a comfortable ultra-thin design. Black or Tan. Omnidirectional Sold separately as components</p> </div> <div data-bbox="774 785 969 1163">  <p>WBH54 This Beta microphone features a smooth, tailored response for a warm, natural sound. Black or Tan. Supercardioid Sold separately as components</p> </div> <div data-bbox="990 785 1185 1100"> <h3>GUITAR</h3>  <p>WA302 Links a Bodypack Transmitter to a guitar or bass. ULXP14</p> </div> <div data-bbox="1206 785 1401 1121"> <h3>INSTRUMENT</h3>  <p>WB98H/C A versatile solution for high volume wind, brass or percussion. ULXP14/98H</p> </div> </div>			

OPTIONAL ACCESSORIES

PA805 UHF Passive Directional Antenna	UA505 Remote Antenna Bracket and BNC Adapter	UA860 UHF Passive Omni Directional Antenna
RK323G Black grill replacement option for Beta 58A	UA506 Rack Mount Kit for one ULX Receiver	UA870 UHF Active Directional Antenna
RK324G Black grill replacement option for Beta 87	UA507 Rack Mount Kit for two ULX Receivers	UAPF-X1 In-Line RF Filter
UA221 Passive Antenna Splitter	UA830 UHF Active Remote Antenna Amplifier	WA610 Universal Hard Carrying Case
UA440 Front Mount Antenna Cable Kit	UA844 Antenna/Power Distribution System	WA615M Handheld transmitter ID rings (5 assorted colors)

ULXP4
Professional Diversity Receiver



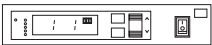
front panel



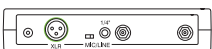
back panel

RF Carrier Frequency Range	470-952 MHz (available frequencies depend on applicable country regulations)
Working Range	100 m (300 ft) under typical conditions (NOTE: Operating range depends on many variables, including RF signal absorption, reflection and interference)
Audio Frequency Range	25-15,000 Hz, ±2 dB (NOTE: Overall system frequency response depends on microphone element)
Audio Output Level (ref. ±38 kHz deviation, 1 kHz tone)	XLR connector (into 600Ω load): +8 dBV (line); -10 dBV (mic) 1/4-inch connector (into 3kΩload): +2 dBV

ULXS4
Standard Diversity Receiver



front panel



back panel

Impedance	ULXS4 and ULXP4 (output): 3kΩ(1/4-inch phone jack) 20kΩ(XLR Line) 500Ω(XLR Mic)
Modulation	±38 kHz deviation compressor-expander system with pre- and de-emphasis
Dynamic Range	>105 dB, A-weighted
RF Sensitivity	1.26 mV for 12 dB SINAD (typical)
Image Rejection	65 dB typical
Spurious Rejection	75 dB typical
System Distortion (ref. ±15 kHz deviation, 1 kHz modulation)	0.3% (<1%) THD typical
Power Requirements	ULXS4 and ULXP4: 14-18 Vdc (negative ground), 600 mA; external ac adapter supplied.
Operating Temperature Range	-20 to 50 C (-4 to 122 F) (NOTE: Battery characteristics may limit this range)
Overall Dimensions	ULXS4: 41 mm H x 219 mm W x 152 mm D (1 5/8 x 8 5/8 x 6 in.) ULXP4: 44 mm H x 219 mm W x 154 mm D (1 3/4 x 8 5/8 x 6 1/16 in.)
Net Weight	ULXS4: 0.6 kg (1 lbs 4 oz) ULXP4: 1.02 kg (2 lbs 4 oz)

ULX1
Bodypack Transmitter



top panel

Gain Adjustment Range	40 dB (continuously adjustable)
Impedance	input: 1 MΩ
RF Power Output	30 mW maximum (dependent on applicable country regulations)
Power Requirements	9 V alkaline battery (DURACELL® MN1604 recommended); 8.4 V optional
Battery Life	Up to 8 hours
Overall Dimensions	95.2 mm H x 63.5 mm W x 33.3 mm D (3 3/16 x 2 5/8 x 1 1/16 in.)
Net Weight (without battery)	90.7 g (3.2 oz)

ULX2
Handheld Transmitter



Gain Adjustment Range	25 dB (continuously adjustable)
RF Power Output	30 mW maximum (dependent on applicable country regulations)
Power Requirements	9 V alkaline battery (DURACELL® MN1604 recommended); 8.4 V optional
Battery Life	Up to 8 hours
Overall Dimensions	ULX2/58, ULX2/BETA 58: 241 mm L x 50.8 mm Dia. (9 1/2 x 2 in.) ULX2/87, ULX2/BETA 87: 216 mm L x 50.8 mm Dia. (8 1/2 x 2 in.)
Net Weight (without battery)	ULX2/58, ULX2/BETA 58: 298 g (10.4 oz) ULX2/86, ULX2/87, ULX2/BETA 87: 195 g (6.8 oz)



**United States, Canada,
Latin America, Caribbean:**
Shure Incorporated
5800 West Touhy Avenue
Niles, IL 60714-4608 USA

Phone: 847-600-2000
Fax: 847-600-1212 (USA)
Fax: 847-600-6446
Email: info@shure.com

Europe, Middle East, Africa:
Shure Europe GmbH
Wannenäckerstr. 28,
74078 Heilbronn, Germany

Phone: 49-7131-72140
Fax: 49-7131-721414
Email: info@shure.de

Asia, Pacific:
Shure Asia Limited
22/F, 625 King's Road
North Point, Island East
Hong Kong

Phone: 852-2893-4290
Fax: 852-2893-4055
Email: info@shure.com.hk

CITY OF CAMBRIDGE

AUDIOVISUAL RENOVATIONS

Acoustics Narrative

Prepared For:

LDa ARCHITECTURE AND INTERIORS

Presented By:

ACENTECH INCORPORATED

June 24, 2013

TABLE OF CONTENTS

1.	GENERAL SUMMARY	3
2.	INTRODUCTION	4
3.	SULLIVAN CHAMBER	5
4.	ACKERMANN ROOM	10
5.	SOPHIE J. ANASTOS ROOM	12
6.	MEETING ROOM, BASEMENT, LOMBARDI BUILDING	14
7.	MULTIPURPOSE ROOM - SENIOR CENTER	15
8.	COMMUNITY ROOM - CITY HALL ANNEX	19
9.	MEETING AREA - WATER DEPARTMENT	21
A.	APPENDIX A - SOUND ABSORPTIVE TREATMENTS	24

GENERAL SUMMARY

1.0 **GENERAL:**

This document focuses on the acoustics design goals and preliminary recommendations as they relate to the City of Cambridge City Hall, the Cambridge Senior Center, Lombardi Building, Waterworks, and the City Hall Annex. A separate program document was provided by Acentech Incorporated for audiovisual programming.

In conjunction with the audiovisual upgrades proposed, acoustics upgrades are also important. This includes room acoustics to improve speech intelligibility, sound isolation from the adjacent spaces, as well as noise and vibration control of both the proposed and existing HVAC system.

1.1 **CONSIDERATIONS:**

The purpose of this acoustics narrative is to present design goals to complement the audiovisual systems proposed. This includes potential architectural modifications to improve the acoustics conditions of the various spaces. Other items of consideration relate to the design and layout of the mechanical system as they relate to potential noise impact to the spaces.

INTRODUCTION

2.0 **ACOUSTICAL DESIGN GOALS:**

To improve the audiovisual experience for all these spaces, acoustical goals must be established early in design. The goals include three major areas: (1) background sound levels, (2) room acoustics, and (3) sound isolation from the adjacent spaces.

2.1 **BACKGROUND SOUND LEVELS:**

The background sound level of each space is mainly controlled by the HVAC system serving the space. This can be a range of noise sources, such as the fan noise, structure borne, duct breakout noise caused by air turbulence, and airflow noise within the duct and at the air terminals.

Background sound levels are typically expressed in Noise Criteria (NC), which are based on a set of curves established for rating HVAC noise in the indoor environment. The NC rating is determined from octave-band sound pressure levels between 63 Hz to 8000 Hz by the tangency method.

Background sound level measurements are measured with a Class 1 integrating sound level meter, Rion model NA-28.



Sound level meter (image: Rion)

2.2 **ROOM ACOUSTICS:**

One of the most common metrics in evaluating room acoustics is to use the Reverberation Time (RT_{60}). This is the time it takes for the direct sound energy to decay by 60 dB in a space. A shorter RT_{60} within a space is typically described as a “dry” or “dead” space, while a longer RT_{60} is described as a “live” space. For rooms with microphones and speakers for speech communication, a lower RT_{60} will generally be more beneficial. The shape of the room and the location of the sound

absorptive/reflective surfaces will also be a factor in the designing a good space for speech communication.

The measurements of RT_{60} are taken with the Electronic and Acoustic System Evaluation and Response Analysis (EASERA) software in conjunction with Earthworks M Series microphones.

The type of finishes in the room will impact the RT_{60} of the space. How much sound is absorbed by the selected finish is typically expressed by Noise Reduction Coefficient (NRC). This is a single average number based on the absorption between 250 Hz and 2000 Hz. NRC 1.0 represents 100% sound absorptive. NRC 0.5 represents 50% absorptive and 50% reflective.

2.3 **SOUND ISOLATION:**

In addition to providing low background sound levels and appropriate reverberation times, noise intrusion from adjacent spaces can also be a concern. This includes noise from above or below as well as from the adjacent rooms on the same floor. The most common metric for expressing sound isolation of a wall or floor/ceiling assembly is the Sound Transmission Class (STC). This is a single number rating determined based on laboratory measurements of the sound transmission loss through the assembly between 125 Hz and 4000 Hz. Field STC measurements are often expressed in Noise Isolation Class (NIC), which is generally lower (5 to 8 points) than the STC rating. Sound isolation upgrades typically require major renovations of the wall and floor/ceiling assemblies, which are not anticipated for this project.

Sound isolation measurements are taken with a Class 1 integrating sound level meter, Rion model NA-28.

SULLIVAN CHAMBER

3.0 **EXECUTIVE SUMMARY**

The replacement of the existing acoustical ceiling tiles with new acoustical ceiling panels is necessary for the chamber hall and also the CCTV control room. Retractable velour curtains are also highly recommended to improve the acoustics of the room. Door gaskets are needed to provide adequate sound isolation from adjacent spaces.

3.1 **OBSERVATION & EXISTING CONDITIONS**

There have been complaints about noise build-up within the space as well as poor speech intelligibility. We measured the RT_{60} with the EASERA system and determined the RT_{60} to be 1.0 second.

The ceiling has direct-applied acoustical ceiling tiles as shown in the image below, which has been painted over. We also noticed during our acoustical measurements that there is a delayed sound reflection. This delay is most likely from the balcony or the high ceiling of the hall.



Hatched area indicating existing acoustical ceiling tiles

The existing CCTV control located at the balcony level will remain at the same location.

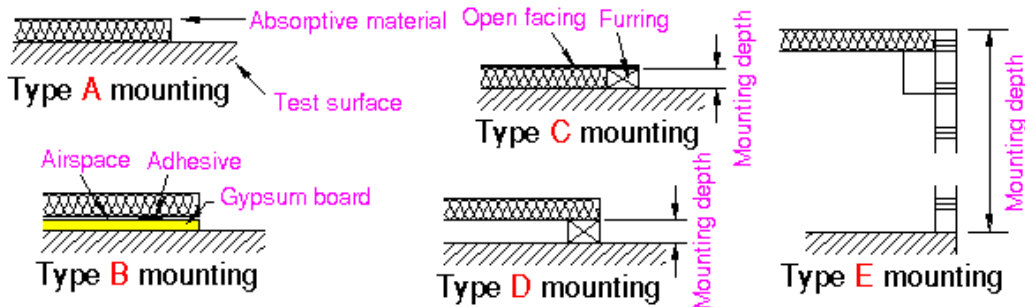
No modifications or additional equipment are planned for providing fresh air to the chamber hall.

3.2 **RECOMMENDATIONS**

We measured the RT_{60} during our visit to the chamber hall and determined this to be about 1.0 second, which is a little more reverberant than desired. The recommended RT_{60} for this space is 0.7 seconds or lower to help reduce excessive and delayed reflections from the sound reflective surfaces.

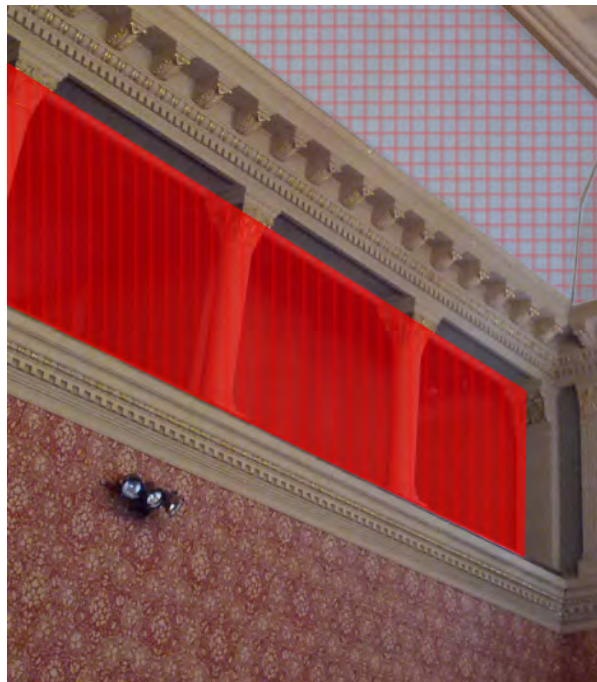
Replacing the existing acoustical finishes with more sound absorptive finishes will be necessary to achieve a lower reverberation time in this space. This will involve replacing the existing acoustical ceiling tiles surface mounted on the existing ceiling surfaces including the coffers with finishes such as glass fiber panels, stretch fabric over glass fiber material, or acoustical plaster. Appendix A attached shows a list of acceptable products for the ceiling.

Regardless of the type of sound absorptive finish selected, the minimum Noise Reduction Coefficient (NRC) of the material should be 0.70 (with Type A mounting, see figure below).



Various mounting options for acoustical treatment (image: www.simonisystems.com)

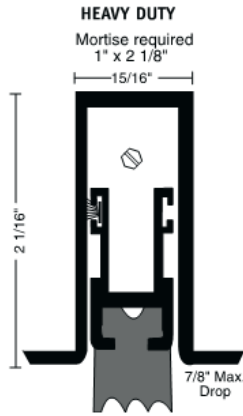
The delayed sound reflection can also be reduced by providing a retractable velour curtain to separate the balcony space from the main chamber. The velour curtain should be at least 18 oz and provide at least 50% fullness when extended. While this is not necessary for reducing the reverberation time, it is beneficial for reducing the delayed sound reflections.



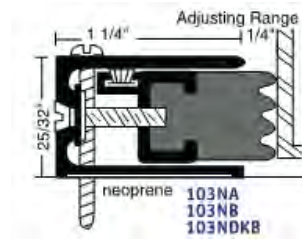
Retractable curtain at the balcony level (shaded in red, not actual color)

The hall is well sound isolated from the adjacent spaces based on the room configurations, with the exception of the main entrance which opens directly to the corridor. The addition of door gaskets around the main entrance hall can help reduce noise intrusions from the corridor during a meeting. Automatic door bottoms should be provided in conjunction with door thresholds.

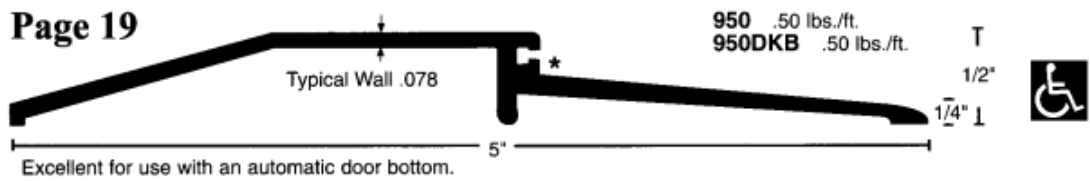
TYPICAL DOOR GASKETING



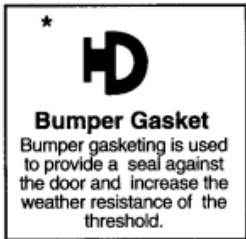
Automatic door bottom



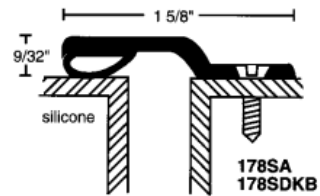
Adjustable perimeter door gasket



Door threshold



Bumper gasket for the threshold



Astragals

The door to the CCTV control room must also be provided with similar door gaskets, threshold, and automatic door bottom. The ceiling of the control room should be fully sound-absorptive with acoustical ceiling panels with minimum NRC rating of 0.70. Two adjacent sides of the control room should have 1" thick acoustical wall panels from chair rail height to the finish ceiling, with NRC rating of 0.90.

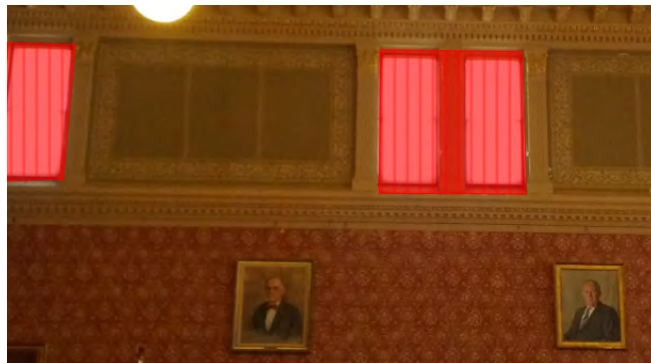
3.3 **COORDINATION**

The line array speaker system provided by the AV consultant will provide a more directional sound source to the users within the chamber hall, thus reducing the potential of undesirable sound reflections and noise build-up.

The current MEP plan is to remove the existing cast iron radiators and provide additional heat to the space with the use of low profile Runtal RS2 radiators. This modification should not increase the background sound level of the space. See the MEP narrative for recommendations.

3.4 **ADDITIONAL CONSIDERATIONS**

While it is mentioned in the audiovisual programming document that the proposed loudspeakers will provide satisfactory speech intelligibility under reverberant conditions, the space will likely still have noise build-up issues when a loud person (or multiple persons) excite the room. Having the additional sound-absorptive treatments can help reduce noise build-up caused by such instances. The best solution will be to add motorized velour curtains to: (1) darken the space as necessary and (2) provide acoustical benefits (18 oz or more) with at least 50% fullness when extended. If velour curtains are used for all the windows and the balcony, this is sufficient acoustically.



Velour curtains at all windows (shaded in red, not actual color)

Acoustical wall panels are also an acceptable finish in lieu of velour curtains, although this is not an option due to the limited locations for mounting them. The panels would need to mount at approximately the same height as the historic stenciled plaster wall, which is not acceptable.

ACKERMANN ROOM

4.0 **EXECUTIVE SUMMARY**

The replacement of the existing acoustical ceiling is necessary to provide adequate acoustics in the space.

The existing split-system air conditioner should be replaced with a quieter split-system air conditioner.

4.1 **OBSERVATION & EXISTING CONDITIONS**

Currently the space has a split-system air conditioning system. While this is a relatively quiet system, background sound level still measured NC-40. With the air conditioning system turned off, background sound level is around NC-20. There are also two ceiling fans in the room. These fans are very quiet and we measured NC-25 without the air conditioner.

The room finishes of this space consists of acoustical ceiling panels and wood wall panels. The floor is carpeted. The ceiling panels have been painted over and the sound-absorptive finish is probably compromised. There is also some water damage visible on the existing acoustical ceiling tiles.

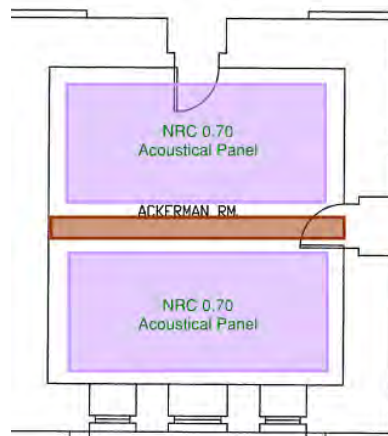


Water damage to acoustical ceiling tiles

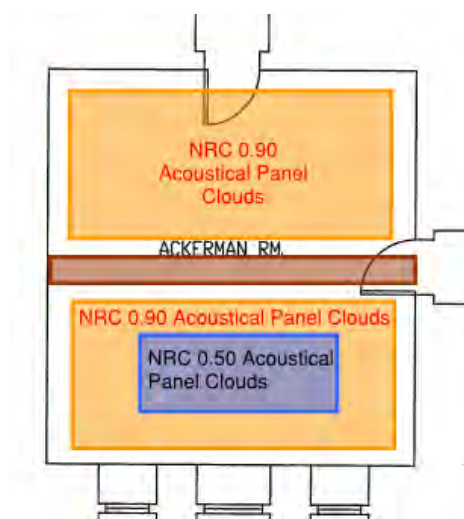
4.2 **RECOMMENDATIONS**

To achieve NC-25 background sound levels for this space, we recommend that the existing AC unit be turned off during videoconferencing. A better option for this room would be to install a quieter split system AC unit. The new AC unit proposed by the mechanical engineer will achieve NC-25 when set at “Quiet” or “Low” fan settings.

There are two options in providing appropriate treatments to this room for videoconferencing capabilities. The existing acoustical ceiling tiles need to be replaced with new acoustical ceiling treatment, or panels. The first option is to use the same ceiling panels for the entire ceiling. The ceiling panels should be NRC 0.70 to provide a reverberation time of 0.5 second or less.



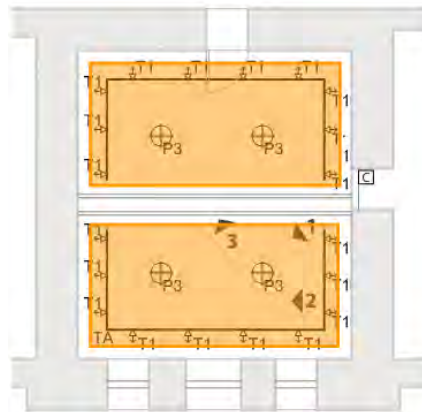
The second option to promote unamplified speech communication across a wider distance (across the large conference table) is to have the center of the ceiling right above the table more sound-reflective (NRC 0.50) and the perimeter portion of the ceiling more sound-absorptive (NRC 0.90).



The main entrance into the Ackermann room opens to the main stairwell of the city hall. There is a significant amount of foot traffic and the corridor floor is terrazzo. To provide a higher level of sound isolation, the door must be provided with perimeter gasket, automatic door bottom, and threshold.

4.3 **COORDINATION**

Coordination between the acoustical ceiling panels and the lighting track will be important. The following figure shows approximate acoustical cloud location in relation to the lighting tracks proposed by the lighting consultant.



Proposed ceiling layout and lighting tracks

4.4 **ADDITIONAL CONSIDERATIONS**

The door to the City Council offices should also be sealed with perimeter door gaskets, automatic door bottom, and threshold.

If the carpet will be replaced, the floor should remain carpeted.

SOPHIE J. ANASTOS ROOM

5.0 **EXECUTIVE SUMMARY**

Replacement of the window air conditioning unit will be necessary to achieve acceptable background sound levels. This new unit needs to be set at “Quiet” or “Low” fan settings during videoconferencing.

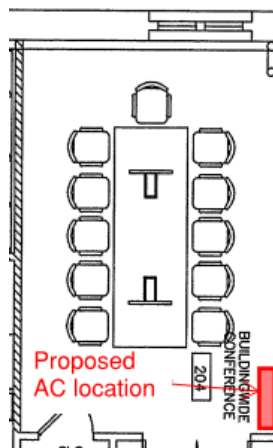
5.1 **OBSERVATION & EXISTING CONDITIONS**

Acoustically this meeting room has a relatively updated acoustical ceiling, which appears to be in good condition. The air conditioning unit is currently a window unit mounted on the window next to the audiovisual screen. We measured background sound level of NC-50 with the air conditioning unit on, which is unacceptable. With

the air conditioning unit turned off, background sound level measured below NC-25.

5.2 **RECOMMENDATIONS**

To achieve NC-25 background sound levels for this space, a new split air conditioning system is planned to serve this space, please refer to the MEP narrative for specific recommendations. Similar to the Ackerman Room, the new split air conditioning system is acceptable for most purposes. Recommended location for the air conditioner is shown in the figure below. The new air conditioning system can be shut off during videoconferencing.



The other option to achieve NC-25 without shutting the air conditioning off is to provide a central air conditioning system, such as an air handling unit with fan coil unit or a variable air volume unit serving the Sophie Room. The fan coil unit or terminal box must be located outside of the conference room, ducted into the space with acoustically lined ducts that are designed at 420 fpm or lower on the supply air side and 490 fpm or lower on the return air side. The diffusers and registers must be rated at NC-20 or lower at maximum air flow.

This space already has a very low reverberation time of about 0.5 seconds, which is good for the function of this space. If there are plans to replace the existing acoustical ceiling panels in this room, these panels should achieve NRC 0.70.

To provide a higher level of sound isolation, the door should be sealed with perimeter gaskets, astragals, automatic door bottoms, and astragals.

5.3 **COORDINATION**

No additional comments here.

5.4 **ADDITIONAL CONSIDERATIONS**

No additional comments here.

MEETING ROOM, BASEMENT, LOMBARDI BUILDING

6.0 EXECUTIVE SUMMARY

Existing mechanical air distribution duct to the room is noisy and should be updated to meet the AV requirements.

6.1 OBSERVATION & EXISTING CONDITIONS

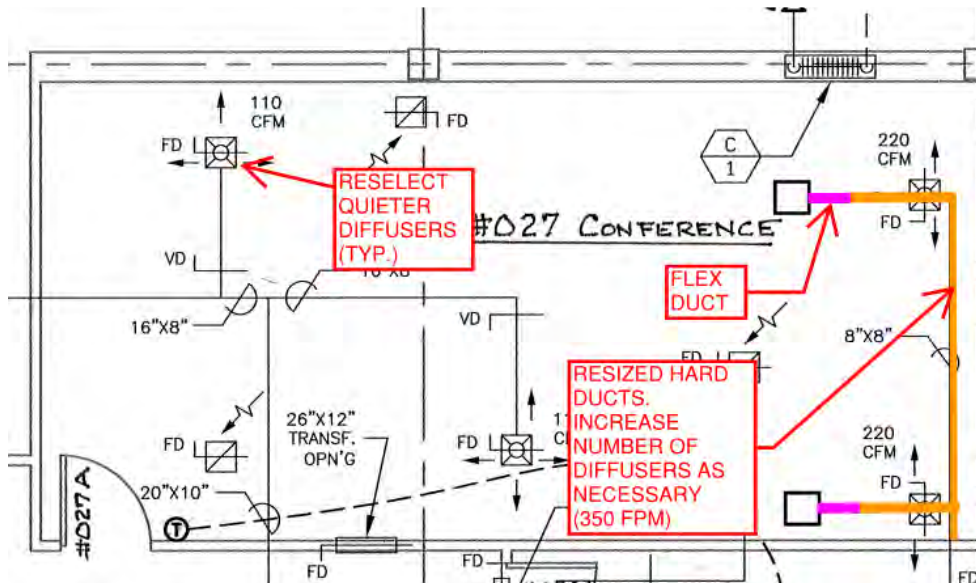
This meeting room in the Lombardi Building on 831 Massachusetts Avenue has 100% acoustical ceiling panel, and the floor is carpeted. However, the mechanical system serving this room is noisy and the background sound level measured was NC-40 in the middle of the room. The air diffuser at the front of the room generated excessive airflow noise and measured up to NC-47.

6.2 RECOMMENDATIONS

The background sound level of this room should be designed to NC-25 to be compatible with the videoconferencing capabilities. This will require providing new HVAC equipment and more generously sized air distribution ductwork to allow for slow airflow velocities.

On the supply side, there are two terminal boxes that serve this area. Ducts downstream of VAV#2 serving the rear half of the room are sized adequately (less than 200 fpm), but ducts downstream of VAV#4 are sized closer to 500 fpm. Resizing the ducts downstream of VAV#4 to achieve 375 fpm or lower will help reduce airflow noise to NC-25. This can be achieved by either resizing the existing duct or adding additional diffusers with new ductwork so the air volume to each diffuser decreases. All supply ducts should be provided with 3-ft. of flexible ducts to the diffusers.

The diffusers should all be replaced with new diffusers that are rated at NC-20 or lower at maximum airflow. The return air registers do not seem to be an issue and do not need to be replaced.



The room finishes are acceptable. If new acoustical ceiling panels are planned, they should be mineral fiber ceiling panels that achieve minimum NRC rating of 0.70.

No further sound isolation upgrades seem necessary for this space.

6.3 **COORDINATION**

Mechanical system updates will need to be coordinated with the mechanical engineer, please refer to the MEP narrative for specific recommendations on updating the ductwork.

6.4 **ADDITIONAL CONSIDERATIONS**

No additional comments in this section.

MULTIPURPOSE ROOM – SENIOR CENTER

7.0 **EXECUTIVE SUMMARY**

The operable partition has visible gaps at the bottom of the panels that need to be sealed. The mechanical system serving the rooms are currently noisy and unacceptable for CCTV recording purposes and general use of the rooms.

7.1 **OBSERVATION & EXISTING CONDITIONS**

This flat-floor room is divisible into two smaller rooms of unequal size using an operable wall. The existing speech reinforcement is of poor quality and the excessive levels of HVAC system noise reduce the effectiveness of the sound system further. Background sound levels measured ranged between NC-42 and

NC-45, noisiest at the entrance of the smaller multi-purpose room. This is most likely a combination of the noise from the mechanical riser, casing radiated noise from the fan-powered terminal boxes, and airflow noise from ducts that are sized inadequately. In addition, half of the diffusers are blanked off from the air distribution ducts, creating higher airflow velocities at the connected diffusers.

The operable wall is functioning although the gaskets at the bottom of the panels are not always sealed to the floor. There were clear gaps (up to 1" wide) at the bottom, reducing the sound isolation of the operable wall.



Clear gap at the bottom of the operable partition.

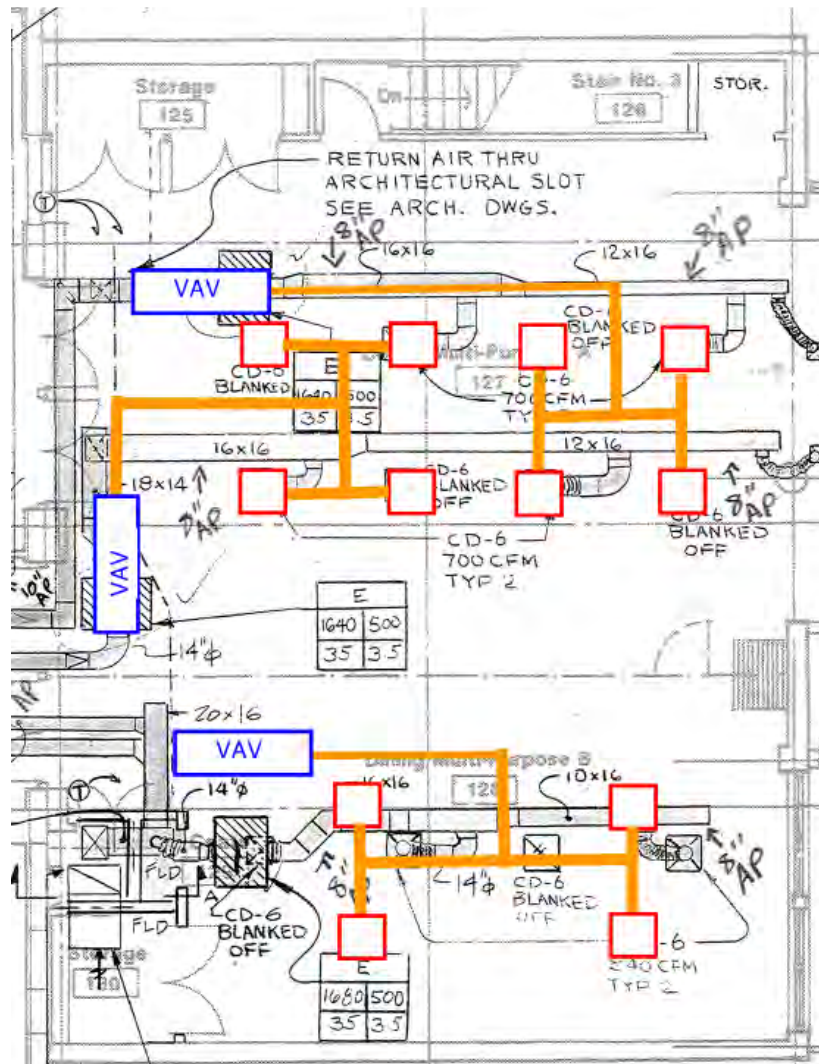
The top of the track appears to be met with a gypsum soffit, although this was difficult to determine with the existing steel beams that also are located parallel to the operable walls. Sound isolation testing of this operable wall resulted in NIC 31, which is about the same as a solid wood door with no gaskets. Standard single stud insulated wall constructions without doors will typically test better, at least NIC 40.

The room is currently used periodically by CCTV for video recording; it would be desirable to be able to broadcast live from there. The current background sound levels will not be suitable for such use.

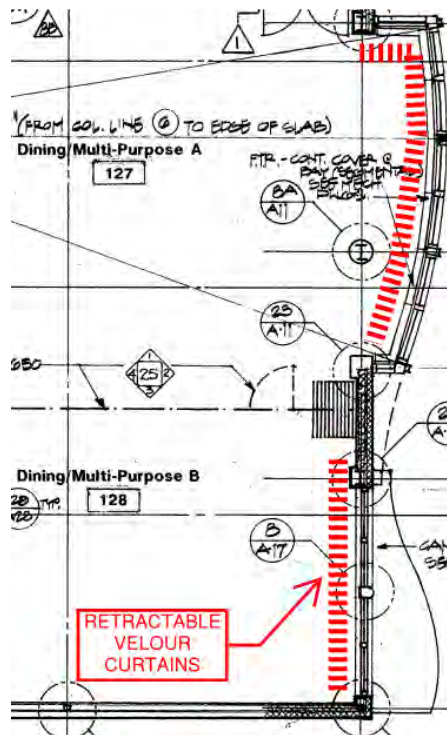
None of the doors are currently gasketed. This includes doors to the corridor as well as doors to the dining area.

7.2 **RECOMMENDATIONS**

The background sound level of this room should be designed to NC-25 to be compatible with the videoconferencing capabilities. It is necessary to provide new air distribution ductwork for the multi-purpose rooms. The fan-powered boxes are not necessary and can be changed to standard variable air volume terminal box, which are quieter. Once the blanked-off diffusers are open, duct airflow velocities will be close to the design goal of 375 fpm. The figure below shows the recommended duct layout based on the existing diffuser locations. Air volume dampers should be at least 5-ft. from the diffusers, and the diffusers should be rated at NC-20 at maximum airflow.



The acoustical ceiling panels are in decent condition. If new acoustical ceiling panels are planned, they should be mineral fiber ceiling panels that achieve minimum NRC rating of 0.70. For CCTV recording purposes, retractable velour curtains should be provided around the perimeter of the room, which can act as a sound absorptive material and also block light. The velour curtains should be at least 14 oz. curtains, with 100% fullness when extended.

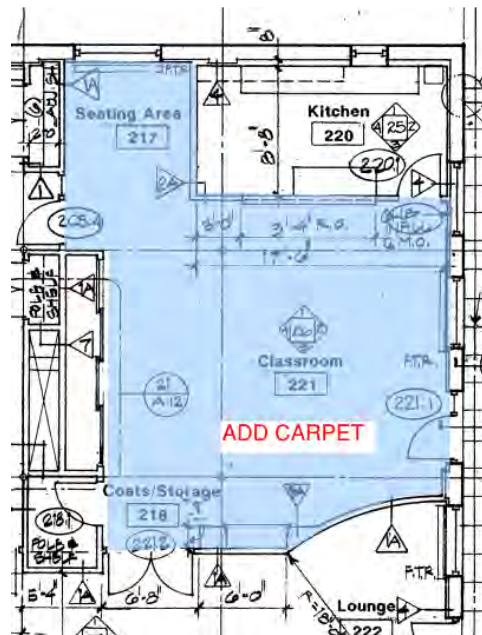


Location of velour curtains

Once the background noise level of the space is lower, we anticipate that the existing sound isolation with the operable partition will be insufficient even after the adjustment of the gaskets and panels. This is because there is less mechanical noise to mask the signal from the adjacent spaces. A new operable partition will be necessary to provide a higher level of sound isolation. The new operable partition should be rated at STC 51 or higher. There should not be an access door at the operable wall as this reduces the sound isolation performance of the partition.

Similarly, once background sound level is lower, noise intrusions from the dining areas and the corridor will be more apparent. Although this is currently not a problem for the users of this space, noise intrusion from the corridor area into the space is a concern for CCTV recording sessions. Sound isolation can be improved by the addition of perimeter door gaskets, thresholds, astragals, and automatic door bottoms.

There are also two sets of double-doors between the larger multi-purpose room and the dining area. The doors must be provided with gaskets and threshold should be provided.



Recommended carpet area for 2nd floor

7.3 **COORDINATION**

Coordination with the MEP design is critical in reducing background sound level in this space. Door gaskets, wall construction, the addition of carpets and retractable curtains must be coordinated architecturally.

7.4 **ADDITIONAL CONSIDERATIONS**

We also noticed some impact noise intrusions into the Multi-Purpose Rooms during our visit. This included some footfall noise but mostly chair moving noise, which can be intrusive to CCTV recordings. Impact noise can be easily reduced by adding carpet to the second floor classroom.

COMMUNITY ROOM – CITY HALL ANNEX

8.0 **EXECUTIVE SUMMARY**

Minor modifications to the HVAC ductwork on are necessary to reduce noise generated from the supply opening to lower the background sound level to an acceptable level.

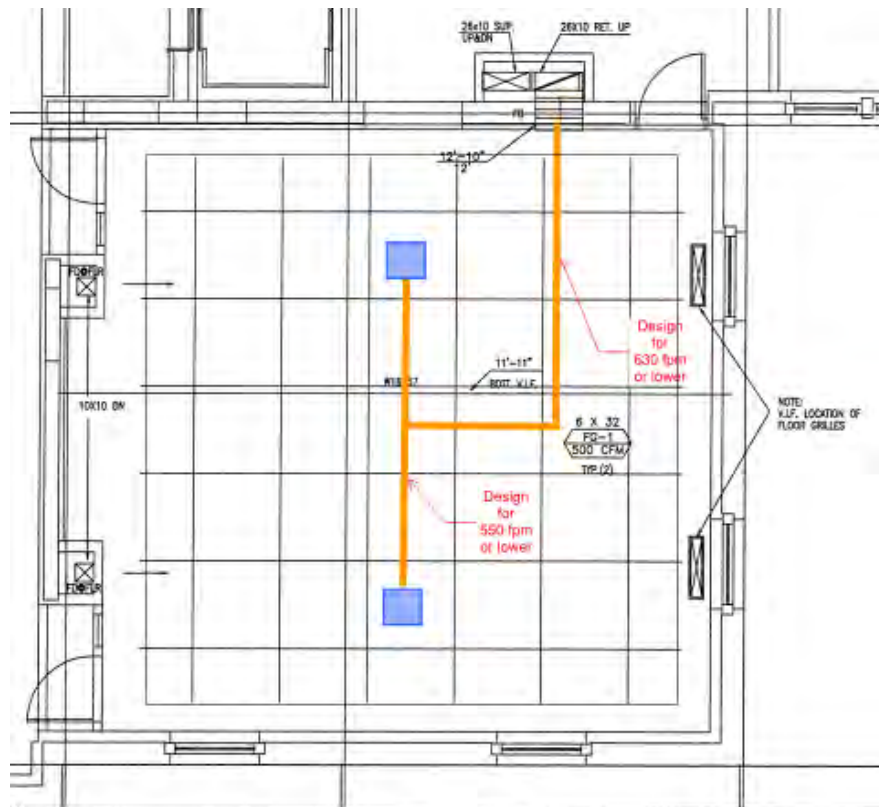
8.1 **OBSERVATION & EXISTING CONDITIONS**

The room is recently renovated and the finishes are in good condition. The HVAC system is generally quiet except for one return air opening, which happens to be at the front of the room. Airflow velocity at the air register is at least 1100 fpm,

significantly higher than recommended. The background sound level measured NC-35 in the middle of the room and NC-38 directly under the main return opening.

8.2 **RECOMMENDATIONS**

The focus of this room is for audiovisual presentations and not for videoconferencing purposes. The background sound level of this room should be designed to NC-30. This is sufficient for typical speech communication and audiovisual presentations. Return air ductwork must be extended from the wall register to reduce airflow velocity and thus also reduce noise.



8.3 **COORDINATION**

Coordination between the mechanical and architectural designs is important to allow adequate duct sizes for low air velocities without compromising the height of the existing ceilings. Location of the return air registers should also be carefully coordinated to fit the 4x4 ceiling panels.

8.4 **ADDITIONAL CONSIDERATIONS**

No additional comments in this section.

MEETING AREA – WATER DEPARTMENT

9.0 EXECUTIVE SUMMARY

Additional sound absorptive treatments are necessary at the ceiling and walls to decrease the reverberation time and reduce noise build-up during meeting in this space.

9.1 OBSERVATION & EXISTING CONDITIONS

The entry area at the Water Department at Fresh Pond is frequently used for assemblies too large for the one remaining conference room (the original conference/training room has been taken over to serve as an Emergency Operations Center). This area currently has limited sound-absorptive acoustic treatment and the long reverberation time of 3.5 seconds in the speech frequency range. This makes speech intelligibility very poor with the temporary sound systems used in the space.

This is a two-story space with terrazzo floor and gypsum board coffered ceilings. There are some curvatures at the ceiling that can create acoustical focusing of sound rather than evenly distributing the reflected sound.



9.2 RECOMMENDATIONS

The dominant noise in this space is generally coming from the adjacent pump room rather than from the HVAC system. During a presentation, the water fountain should be shut off. Otherwise no additional noise control is needed for the HVAC system.

To achieve a lower reverberation time of 1.0 or less, a significant amount of sound absorptive treatments will be necessary, covering at least 2800sf. of the ceiling

and wall surfaces. It is most effective for the sound absorptive treatments to be evenly distributed over the ceiling and wall surfaces instead of focused in one area of the space. This should be direct-applied glass fiber panels, acoustical plaster, or stretch acoustical canvas as discussed for the Chamber Hall. The selected material should achieve minimum NRC of 0.70 with Type A mounting. The treatments should be applied to most of the ceiling surfaces, in particular the coffers, and the curved ceiling sections. Sound absorption should also be provided to the gypsum board wall surfaces on the upper floor and also near the entrance. The figures below show recommended locations (shaded in blue) for sound absorptive treatments.



Proposed acoustical treatment locations

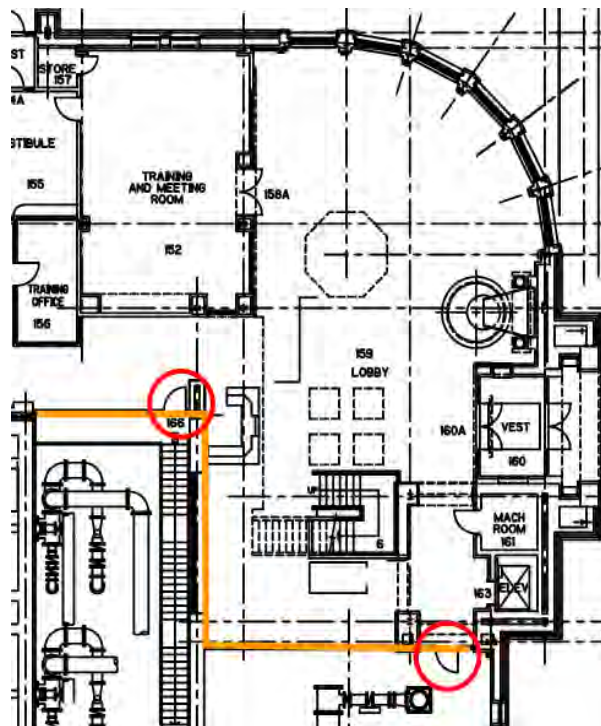
9.3 **COORDINATION**

Architectural coordination is critical in implementing the sound absorptive treatments to make sure that it does not interfere with lighting and diffusers that are flush with the existing ceiling.

9.4 **ADDITIONAL CONSIDERATIONS**

Noise from the pump room and filter gallery can interfere with the meeting space when they are in operation. This is currently not an issue since noise build-up from other noise sources (people, loudspeakers) are a bigger concern. Once the sound absorptive treatments have been added to the space, noise from the pump room will likely be noticeable to the occupants.

At minimum, the doors to the pump room and the filter gallery will need to be provided with perimeter gaskets, automatic door bottoms, and thresholds. For a higher level of sound isolation, which is unlikely necessary at this point, the wall partition and doors should be upgraded.



Add door gaskets and thresholds at these locations

APPENDIX A – ACOUSTICAL FINISHES

Prepared by Acentech Incorporated

<i>Acoustical wall and ceiling panels, direct applied or suspended</i>	
Wall Technology An Owens Corning Company www.walltechnology.com	“New Dimensions” large glass fiber panels with plaster-like appearance
CertainTeed Ecophon www.certainteed.com	“Focus” fiber glass panels, which can be suspended in a grid or directly applied to existing surface. Also available for wall mounting.
Armstrong Industries www.armstrong.com	“Ultima”, suspended mineral fiber ceiling grid panels “Optima” suspended glass fiber ceiling grid panels
Decoustics www.decoustics.com	“Solo” large glass fiber panels with plaster-like appearance
<i>Stretch acoustical canvas with glass fiber backing</i>	
Clipso www.clipso.com/us	Tension acoustic canvas over glass fiber. Sound-absorbing product is Model 495 D.
Novawall www.novawall.com	Stretched fabric over glass fiber
Fabri Trak www.fabritrak.com	Stretched fabric over glass fiber
WhisperWall www.whisperwalls.com	Stretched fabric over glass fiber.
Wall Technology An Owens Corning Company www.walltechnology.com	“Eurospan” Stretched fabric over glass fiber

<i>Acoustical plaster, seamless</i>	
Pyrok Starsilent www.pyrokinc.com	"Starsilent" recycled glass panels with acoustical plaster coating as the final finish
BASWaphon www.baswaphon.com	Glass fiber backing with acoustical plaster coating as the final finish
Fellert www.fellertna.com	Glass fiber backing with acoustical plaster coating as the final finish



**CITY OF CAMBRIDGE AUDIO VISUAL RENOVATION
CAMBRIDGE, MA**

**AV Study – HVAC Component
August 7, 2013**

Performed By:

Steven A. Karan, PE, LEED AP BD+C

SULLIVAN CHAMBER ROOM

I. Executive Summary:

The Sullivan Chamber Room is a critical room for public meetings. Renovation of the room's heating system will greatly reduce the potential disruption of mechanical noise and improve occupant comfort. Two electric fan heaters were added to the room's east wall due to complaints of inadequate heat on extreme cold days. The fans are covered with an open grille and produce an unacceptable noise level when operating. The replacement of the perimeter radiators with a new system (required for an upcoming accessibility renovation) will provide sufficient heating year round and allow for the removal of the disruptive fan heaters.

II. Observations and Existing Conditions:

The Sullivan Chamber Room is currently heated only (no air conditioning or ventilation air provided). The heat is provided by perimeter convectors, with piping run from the platform (*Image 5*), along the perimeter wall to cast iron convectors (*Image 2, 3, 4*). The space also contains a convector adjacent to the Ante Room door and the two fan forced electric heaters. The room is experiencing noise from the two electric heaters located behind a wall grille on the east side of the room (*Image 1*). The two electric heaters were added due to complaints of cold temperatures on extremely cold days. These heaters are fan forced electric coil heaters, which generates an unacceptable noise when run. The noise from the heaters interferes with the TV broadcast and recordings.

The Sullivan Chamber Room is planned to have an upgrade for handicap accessibility, under a separate contract. A new ramp will be added along the perimeter wall and discharge onto the front platform. This ramp will require re-working the perimeter cast iron radiators and piping.

The room also contains four ceiling mounted fans that are used for de-stratification, and for air circulation. These fans add to the noise in the space, when run.

III. Recommendations:

The disruptive noise in the room is from the fans in the electric heaters. These heaters were added due to the requirement for additional heat, to satisfy the heating demand on very cold days. The solution to this noise issue is to add additional heat without the need for fan forced air, which generates noise. The handicap accessibility ramp will require replacing the existing cast iron radiators. The recommended approach, which will satisfy both the noise issue and the handicap improvement renovation, is to provide a new, low profile, radiator along the perimeter walls, Runtal RS2 style convectors (*Image 6*).

The new handicap ramp will be positioned where the existing cast iron radiators and piping are currently located. The recommendation is to remove the two fan heaters and the perimeter radiation and piping, and replace the perimeter heat with appropriately sized

convectors to carry the full load of the space. The new convectors will include a new modulating control valve and thermostat, to adjust the heat output to the space demand. The Runtal radiators can be run the full length of the perimeter wall. The existing piping will be modified to connect to the new convector at the platform, and return at the back of the room, at the location of the existing return.

The ceiling fans should be replaced with a quieter model to reduce some of the noise from a ceiling fan however these fans may need to be turned off for TV broadcasting.



Image 1: Wall grille with fan heaters

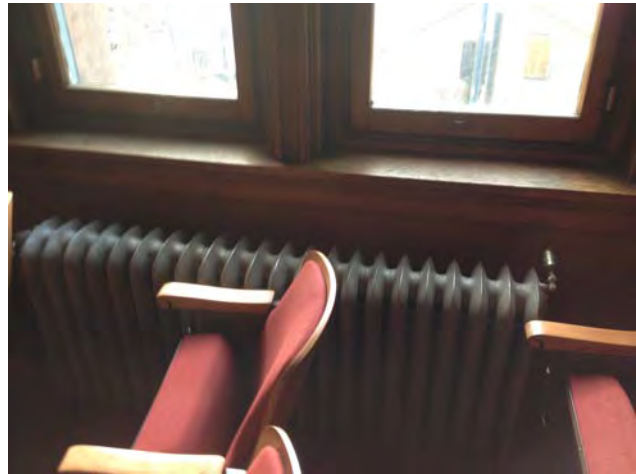


Image 2: Perimeter convectors



Image 3: Perimeter convectors



Image 4: Perimeter convectors



Image 5: Piping along front wall at platform

IV. Coordination:

Coordination with the handicap ramp project will be required for the selection, location and sizing of the perimeter heaters. The design must include enough heat to eliminate the electric fan heaters, and to fit in the ramp and railing design, along the perimeter wall. The ramp will need to be held off the wall to allow enough room for the perimeter heaters. The side wall of the ramp will be required to be open to the perimeter connectors or enclosed with perforated panels to allow for air flow across the heaters.

V. Additional Considerations:

This report addresses the AV issues and does not make recommendations for additional code required items, Exit signage, Emergency lighting and ventilation for the space. This report also does not address the air conditioning of the space, if desired by the City.

The AV Room on the balcony should include a window air conditioning unit to handle the heat load in the space or a ductless split system.

The proposed new lighting will require electrical feeds from the existing electrical panels and circuiting for proposed lighting controls. Power feeds will also be required for AV equipment and conduits for tel/data locations.



Image 6: Runtal Radiator

SOPHIE ANASTOS ROOM

I. Executive Summary:

The air conditioning for the Sophie Anastos Room is by a window HVAC unit. This unit will generate noise and will interfere with future proposed AV systems. Relocating the HVAC system to the west wall and replacing with a ductless split system will allow for a quieter operation of the HVAC system..

II. Observations and Existing Conditions:

The Sophie Room contains a thru-window air conditioning unit (*Image 7*) and perimeter heat. The existing air conditioning unit is a packaged system with compressors, located outdoors in the unit housing, which is part of the thru-window HVAC unit. The noise from the compressors could interfere with the AV system in the room. The proposed AV system will include a sliding presentation screen that will partially block the air flow from the window unit and create both noise and air flow issues, disrupting the operation of the room.

III. Recommendations:

The recommended approach is to provide a split system air conditioning unit with ductless wall mounted unit located high along the west wall and a new condensing unit in the attic (*Image 8*). The condensing unit will be located in the attic with the other building condensing units. The ductless split system will be a much quieter operation for the fan forced air, and relocates compressors from being directly outside the window, up to the attic.

IV. Coordination:

The location of the indoor ductless split unit will need to be coordinated with any other AV devices. The condensing unit will be located in the attic, which will require consideration by the attic ventilation project.

V. Additional Considerations:

The ductless split system will not provide ventilation air. The room will meet the code required ventilation by natural ventilation, based on the operable portion of the windows, meeting the required percent (4% of occupied space) for natural ventilation.

Power will be required to the new room split system and attic condensing unit. The power will be from the existing panel that feeds the existing window unit. Power will also be required for the proposed AV equipment and lighting.



Image 7: Window Air Conditioning Unit



Image 8: Ductless Split System

ACKERMAN ROOM

I. Executive Summary:

The Ackerman Room is currently air conditioned by a ductless split system, located on the front window wall. Based on AV considerations, the unit should be relocated and replaced with a quieter model.

II. Observations and Existing Conditions:

The Ackerman Room contains a ductless split air conditioning unit (*Image 9*) and perimeter heat in the Millwork along the window wall. The existing HVAC unit is hung on the south wall between the windows. The existing split ductless unit would interfere with some AV broadcasting.

III. Recommendations:

The existing ductless split system can be removed, replaced with a new quieter model (*Image 10*) and relocated to the south wall of the room. This will reduce some of the sound in the space and relocate any potential noise to the rear of the room, away from the current table location at the front of the room.

IV. Coordination:

The relocation of the ductless split system will require relocating the power feed to the unit.

V. Additional Considerations:

The ventilation air to the space is not provided by the HVAC system and is to be by natural ventilation, based on the operable portion of the windows meeting the required percent (4% of occupied space) for natural ventilation.

Power will be required for the relocated unit, utilizing the existing circuits. Power will be required for audio/visual equipment and any new lighting.



Image 9: Existing Ductless Split System



Image 10: New Ductless Split System

CITY HALL ANNEX

I. Executive Summary:

The City Hall Annex has been recently renovated, but suffers from unwanted mechanical noise due to high air velocity. Renovations to ductwork and diffuser layout will correct this issue.

II. Observations and Existing Conditions:

The City Hall Annex, second floor Meeting Room, has three HVAC grilles; (2) floor mounted grilles (*Image 11*) and (1) grille up high along the wall (*Image 12*), in the soffited gap along the perimeter of the space. The two floor grilles did not have an objectionable noise level. The grille high in the space is creating an objectionable noise in the space. The noise appears to be air velocity noise at the grille. The air is supplied by a rooftop unit with all ductwork enclosed in sheetrock chases and gypsum ceilings.

III. Recommendations:

The supply air grille creating the noise is ducted from a rooftop unit, with ductwork concealed above ceilings or in wall enclosures. The air velocity at this grille, which creates the noise, will need to be reduced. This can be accomplished in one of two ways:

1. Increase the size of the grille, opening up the wall and flaring out the duct, with a new grille mounted on the enlarged opening. This may not reduce the sound considerably since the velocity noise in the duct will not have enough space to dissipate to a desirable level.
2. Provide ductwork above the dropped ceiling to two ceiling return grilles.

The recommended solution is Option 2, extend the duct at the existing grille, out and into the dropped ceiling area of the room. The duct can then be increased in area to allow the air to expand and operate at a slower velocity, with the addition of two new ceiling grilles with plenum boxes, to reduce the air quantity to a level that returns the air at a low noise level.

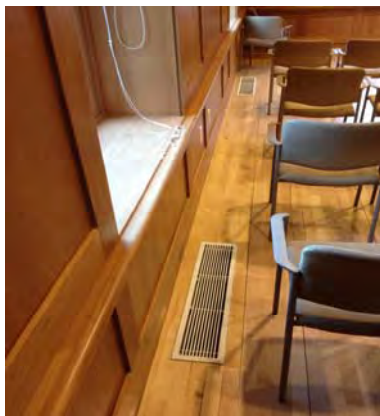


Image 11: Floor grilles

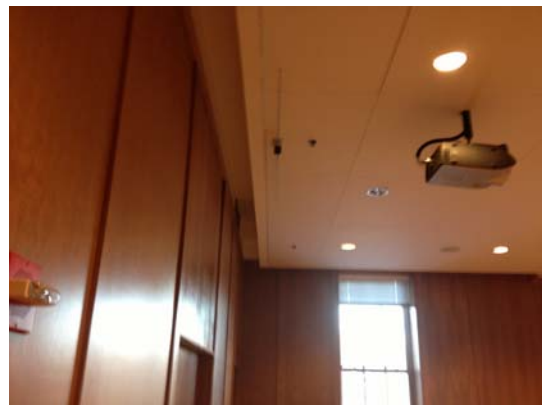


Image 12: Grille located in soffit

IV. Coordination:

The existing ceiling in the majority of the room is dropped, with ceiling mounted lights and AV devices. The ductwork location will need to be coordinated with the existing lights, sprinklers and AV devices.

V. Additional Consideration:

The space should be rebalanced to verify total air flow. One of the floor grilles did not have a noticeable air flow and should be verified.

SENIOR CENTER FUNCTION ROOM

I. Executive Summary:

The Senior Center Function Room has noise issues due to air velocity noise at diffusers, air noise at return locations and vibration noise. Each issue needs to be addressed independently, but they all collectively contribute to a noise level in the room. The HVAC system is “squeezed” into a tight ceiling space, which is contributing to most of the noise. The ductwork distribution will need to be modified, diffusers reselected, air more effectively distributed and corrections made to the rooftop installation.

II. Observations and Existing Conditions:

The Senior Center Function Room has multiple issues with noise in the space, air velocity noise at the diffusers (*Image 14*), air noise from the return air (*Image 13*) and vibration noise. The space is supplied from a large rooftop unit on the second floor roof, adjacent to the roof deck. This unit serves the Senior Center Function Room and the space directly below the Function Room on the lower level. The issue with this space includes:

1. Air Velocity Noise at Diffusers: The space contains three fan powered VAV boxes with two thermostats. Two boxes supply the large section of the room, and one box supplies the smaller section of the room. There is a noticeable air noise at the diffuser from each VAV box.
 - a. The air supply to the VAV boxes is run in a way to avoid crossing the support rail, in the ceiling of the space, segregating the room. The supply air is run back into the corridor, then in a loop back to the room, with multiple bends and offsets filling the dropped ceiling space at the doors as you enter the room. This arrangement is creating air and velocity noise in the ductwork.
 - b. There are four diffusers in a line in the location of each VAV box (*Image 14*). Only two diffusers have supply air, the other two are blanked off. The diffusers are 24”x24” supply grilles with 700 cfm each in the larger portion of the room and 840 cfm each in the smaller portion of the room. The amount of air at the diffusers, with the neck size indicated on the plans, is at an NC listing above 25.
 - c. There are two diffusers in the bay window area at 240 cfm, 12”x12” diffusers, which are above the 25 NC level.
2. Air Noise at Return: There is a dropped ceiling as you enter the room (*Image 13*). This space is used as a return air plenum. The plans indicate an architectural slot in the face of the soffit for the return air. The return air duct from the roof is open ended into this space. The noise at the ceiling is due to a large quantity of air being drawn into the

space, which is full of ductwork and VAV boxes, creating a high velocity of air around the obstructions.

3. Vibration: There is a noticeable vibration in the chase wall immediately to the right of the doors to the room. Vibration noise is transmitted down the wall, to the closets and into the ceiling. The vibration is coming from the rooftop unit.
 - a. The rooftop unit is on steel support rails and posted off the roof (*Image 15 & Image 18*). There are vibration isolators under the unit at the steel rails.
 - b. The return air duct is not properly isolated from the rooftop unit by flexible connections. All vibration from the rooftop unit is being transmitted down the ductwork. The duct connections to the rooftop unit will need to be further isolated.
 - c. The rooftop unit internal components (fan and compressors) should be inspected for proper isolation. The fan may need to be balanced; there was a noticeable rumble at the unit.
 - d. The ductwork runs along the roof into a plenum box and down to the spaces below (*Image 16 & 17*). The attachment of the ductwork and space around the ductwork in the chase needs to be investigated; the duct may not be properly isolated from the chase walls.
 - e. The flexible connectors, for the supply ductwork are compressed and in contact with the rooftop unit. This allows the vibration to transmit along the duct and into the chase walls.

III. Recommendations:

1. **Air Velocity Noise**: The air velocity noise at the diffusers can be corrected with enlarging the ductwork to each VAV box and downstream of each VAV box. Provide lined ductwork. Utilize all diffusers, including the diffusers blanked off for each VAV box. Change out the two smaller diffusers at the windows with larger diffusers.
2. **Air Noise at Return**: The air is returned through a space with limited room for air flow. The system should include larger return air slots, a lower ceiling at the return air path and additional return air grilles in the space with return air boot plenums.
3. **Vibration Noise**: The chase will need to be opened and the ductwork properly supported so that any vibration does not transmit to the chase walls. The duct connections at the rooftop unit will need to be removed and modified to allow for properly sized flex connectors at the supply and return openings on the unit.



Image 13: Dropped ceiling used for return air



Image 14: Ceiling plan, every other diffuser blanked off



Image 15: Typical spring isolator at the rooftop unit



Image 16: Supply ductwork along the roof



Image 17: Return ductwork at roof plenum box



Image 18: Electrical connections at the rooftop unit

IV. Coordination:

The recommended duct velocity to reduce the noise will require coordination of the ceiling. Additional space will be required and a lower ceiling may be needed at the entry and in the space (6 – 8 inches). The rooftop unit will need service to verify and fix the internal vibration.

V. Additional Consideration:

The rooftop ductwork is poorly insulated and ductwork exposed to the exterior. Rigid insulation should be provided on all external ductwork (3” insulation). The connection of the duct to the roof box is leaking with noticeable water stains in the space.

LOMBARDI ROOM

I. Executive Summary:

The existing HVAC system is operating at an unacceptable noise level for a meeting room. Ductwork modifications will reduce the noise level of air supplied to the space.

II. Observations and Existing Conditions:

The Lombardi Room is currently supplied by a central VAV air handling unit with two of the five ceiling supply diffusers on one VAV box (Box 1) and three of the five ceiling supply diffusers on another VAV box (Box 2). The second VAV box (Box 2) also supplies an adjacent space. The thermostat in the room controls the two diffusers/VAV box (Box 1) dedicated to this room. The adjacent room thermostat controls three diffusers/VAV box (Box 2) that supply part of the Lombardi Room and part of the adjacent room.

The thermostats and control are one cause of noise and discomfort in the room. Half the Lombardi Room supply air is controlled by the thermostat in the room which controls air flow supplied to the space by Box 1, based on Lombardi Room space conditions. The other half of the supply air is controlled by an adjacent space, which will cause comfort issues. The thermostat in the Lombardi Room cannot control the Lombardi Room temperature. The noise in the room is due to the inadequate ductwork size and diffuser sizes, which cause air velocity noise in the space.

III. Recommendations:

The Lombardi Room should be supplied by a dedicated VAV box. The work will require removing the VAV box supplying the two diffusers and replace with a new VAV box (660 cfm), with hot water coil and discharge sound attenuator. Remove the supply ductwork from the VAV box and remove and cap the three diffusers from the adjacent space VAV box. Provide new low pressure, low velocity ductwork and six new diffusers, selected below NC20. Rebalance the adjacent space VAV box for the reduced air flow. All ceiling diffusers will require radiation dampers. Provide one additional return grille in the ceiling.

IV. Coordination:

Ceilings will need to be taken down to accommodate the work.

Coordinate ceiling diffusers with any proposed lighting and audio/visual work.

V. Additional Considerations:

The work is recommended based on current systems design and allows the system to properly control the space.

Cambridge City Hall - Sullivan Council Chamber

I. Executive Summary

To remedy the inadequate and unusually gloomy lighting conditions in the Sullivan Chamber, the upgraded lighting system must provide a higher illuminance level on the floor and desk planes for general circulation and in support of paper-based tasks. It must also provide a higher vertical illuminance level for video/broadcasting and general visibility of peoples' faces. It must provide the perception of a brighter overall space and be aesthetically congruent with the historic fabric. Finally, it must be flexible and easily controllable for a host of different program activities.

II. Observations & Existing Conditions

The existing luminous conditions in the Sullivan Chamber are sub-standard. Through initial research, it appears that two major renovations of the space occurred, both of which brought changes to the lighting. The original scheme dating to 1891 indicates a combination of electric and gas lighting through a large central chandelier and numerous wall sconces. These sconces were replaced by the current 'lampshade' fixtures, but original 'flower' fixtures can be found in the gallery. A renovation in 1967 added four new pendants, and replaced the central chandelier with a complimentary pendant. A second major renovation in 1979 maintained much of these pendants, but did replace glass diffusers with the spherical glass globes seen today. The average illuminance level contributed by electric lighting alone, approximately 5fc measured horizontally at 30" AFF, is inadequate for most activities and programs. The illumination for special events, such as broadcasting, are bolstered by wall-mounted floodlights that are glary and aesthetically unappealing.

III. Recommendations

The basic approach to the new lighting system is to recess new luminaires into existing coffers to target speakers and desks, to wash walls, and to provide an overall higher ambient level of illumination in the 20 to 40fc range. These new luminaires should be 'rear re-lampable' since there is an accessible attic directly above these fixtures. In addition, they should also employ long-life sources such as LED's with high color-rendering properties so that re-lamping is an uncommon occurrence. These measures will simplify and reduce operations & maintenance. In addition to the recessed luminaires, a new linear LED cove uplight is being proposed to highlight the ceiling cavity. This will improve perceived brightness of the space while providing soft, shadowless illumination for various tasks. To control and balance new and existing lighting, a scene preset dimming system is recommended. This will most likely be a 12-zone Lutron Graphic Eye system with two remote 4-button control systems (see image at right). The main preset system will be located in the anteroom. LED task lighting should also be included at the council members' desks. To minimize intervention with existing furniture, weighted-base desk lamps are recommended (see L2 - Finelite Curve at right). This will provide energy efficient illuminance with small, visually minimal hardware.

IV. Coordination

Coordination with electrical and mechanical contractors will be important in this space, as fixture locations will need to be coordinated with any altering of wiring or routing of ductwork. Both new or existing ceiling fans will need to be coordinated with the location of recessed downlights. Coordination with AV contractor will be necessary for any control integration between lighting and audio/visual systems.

V. Additional Considerations

Consideration should be given to the removal of the four pendants added in 1967 since the new downlighting will increase overall illuminance, and provide a return to the original style of a single central pendant.



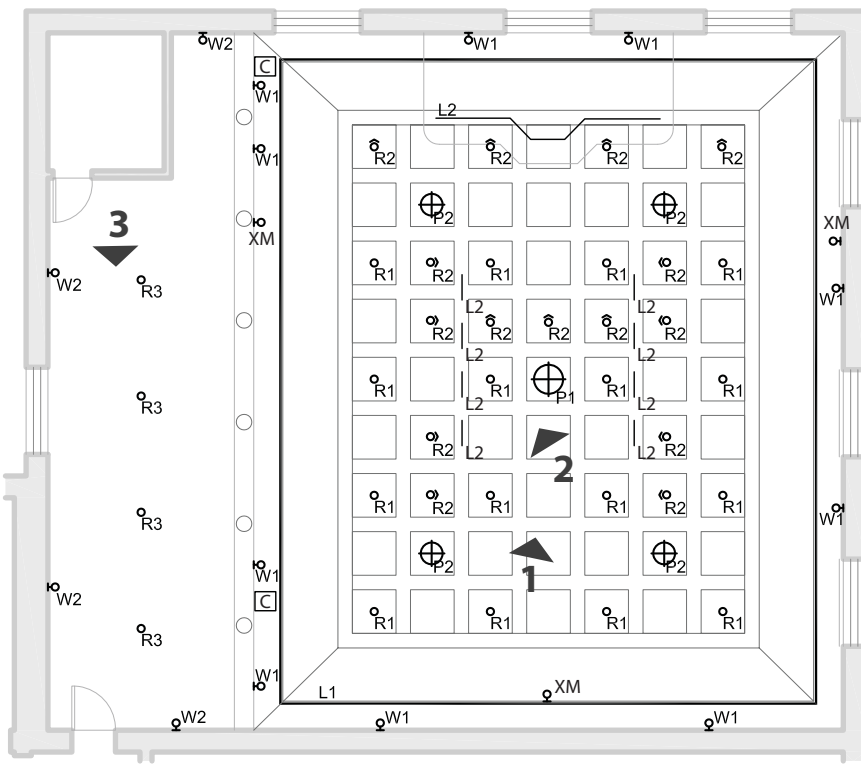
Sullivan Chamber, 1891



View of Dais, 1891



Sullivan Chamber, 1967



L1 - Continuous LED uplight integrated into existing architectural cove

L2 - LED task lighting at desks

P1 - Relamp existing pendant with new LED lamps

P2 - Relamp existing pendants with new LED lamps

R1 - New Recessed LED downlight

R2 - New recessed LED adjustable accent light

R3 - New recessed LED downlight

W1 - Relamp existing wall sconces with new LED lamps. Replace shades. Relocate to be symmetrical @ dias.

W2 - Relamp existing wall sconces with new LED lamps

C - New dimming control for Chamber & Gallery @ dias. Second control to be inside chamber @ entrance.

XM - Existing spotlights to be removed



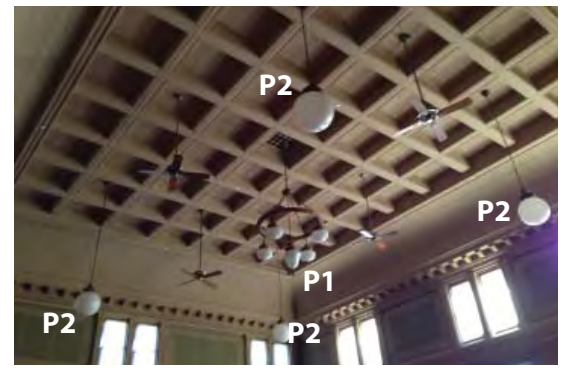
L1-Color Kinetics eW Cove



L2 - Finelite Curve LED task Light



Lutron Remote 4-Button Control System



1.



2.



3.



Computer model of Existing Chamber conditions



Computer model of proposed cove lighting

Cambridge City Hall - Ackermann Room

I. Executive Summary

Considering the unusual layout of the Ackermann room, the proposed lighting strategy will respond to the existing conditions by improving efficiency and better overall light conditions of the room itself. New lighting will be used to help unify the room and provide for programmatic needs.

II. Observations & Existing Conditions

The Ackermann room has many dark finishes and is unusual in its spatial arrangement. The existing track fixtures are not effectively arranged, and the pendants above the conference table are too inefficient, losing light in the shades and creating glare for people seated in the room. The beam running across the center of the room creates a challenge for spatial organization.

III. Recommendations

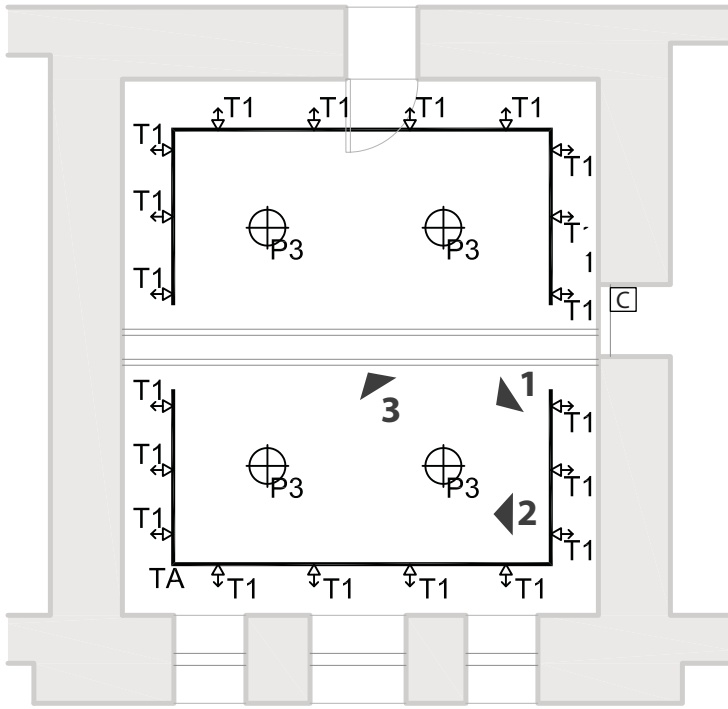
New adjustable track lighting should be wrapped around the room perimeter to highlight portraits and wash otherwise dark walls. It will also provide flexible lighting for presentations. The four pendant fixtures should be relamped with silver bowl incandescent lamps of a higher wattage; these will help redirect light and prevent glare for people seated at the table and around the room. All new lighting can be controlled through a new Lutron Grafik Eye preset dimming system or individual wall box dimmers if preset & AV interface is not necessary.

IV. Coordination

Coordination with AV consultant is critical due to videoconferencing activities. Potential glare on a proposed flat screen mounted to the wall, along with proper illumination of participants' faces, must be considered with the new lighting system.

V. Additional Considerations

Pendant fixtures could be lamped with silver bowl CFL or LED sources, but at this time there are none that exist with appropriate wattage or dimming capabilities.



P3 - Existing Pendant fixtures to be refit for higher wattage lamps

TA - Approx. 60 linear feet of 2-circuit track

T1 - LED track head

C - 4 zone Lutron Grafik Eye dimming control
OR 4 separate wall box dimmers.

NOTE - All existing track lighting in the room should be removed



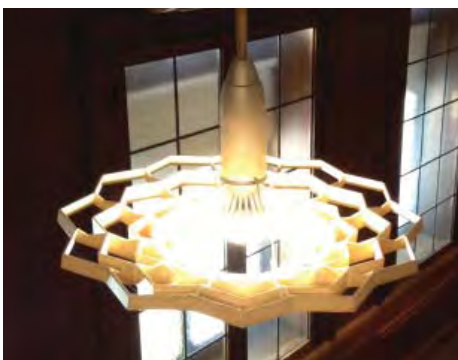
1.



2.



3.



Ackermann Room Pendant



Silverbowl Incandescent Lamp



Lutron Grafik Eye 4-Zone Control Panel

Cambridge City Hall - Anastos Room

I. Executive Summary

The Anastos Room was renovated fairly recently and only requires relamping and cleaning of existing fixtures from a lighting perspective.

II. Observations & Existing Conditions

Existing pendant fixtures have an uneven glow due to the physical size of the installed compact fluorescent lamps. Recessed downlighting and washlighting is relatively less efficient.

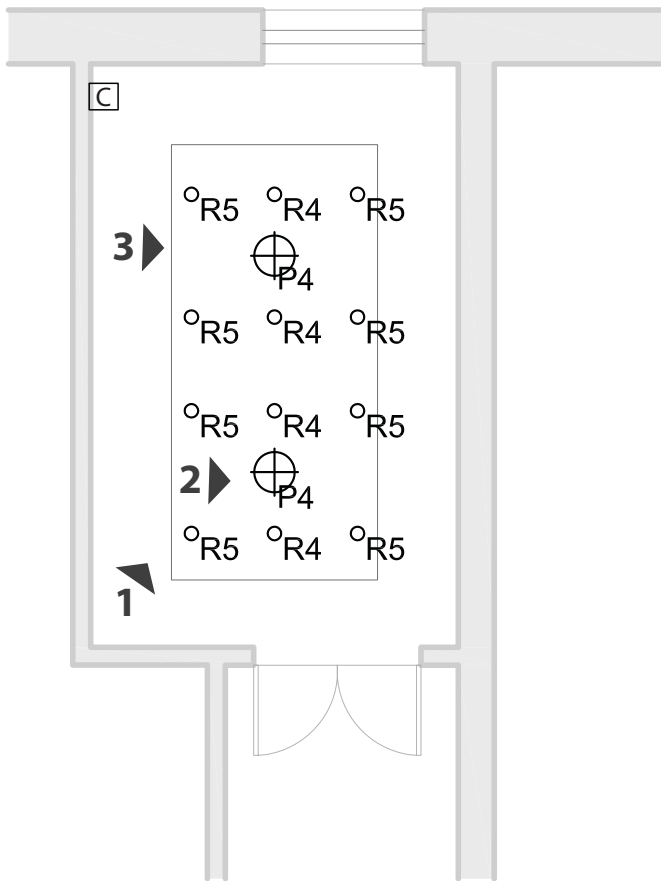
III. Recommendations

Considering how recently the Anastos room was updated, lighting recommendations for the space are limited. Although the downlights and wallwashers are not optically optimum, it's not worth replacing the fixtures at this time. The approach to this room is to simply clean the existing downlights and wash lights and replace the existing lamps with new 3000K compact fluorescent lamps of the same wattage. To remedy the uneven glow of the pendant fixtures, lamps should be replaced by new dimmable 3000K LED A-lamps of similar wattage. These luminaires should also be cleaned free of all debris.

IV. Coordination

No additional lighting controls or AV integration are recommended at this time.

V. Additional Considerations



C - Existing controls to remain

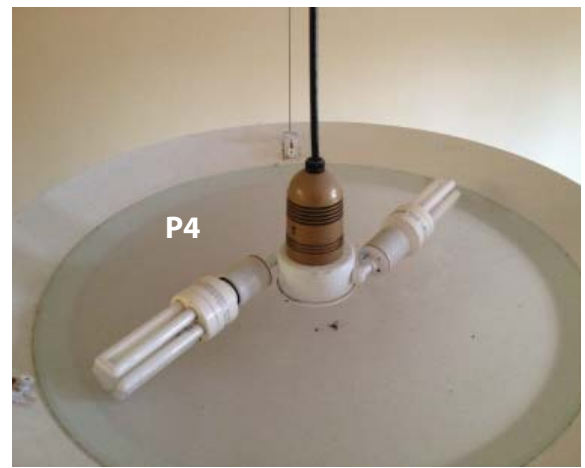
P4 - Clean and Relamp existing pendant with new dimmable LED lamp

R4 - Clean and Relamp existing recessed downlight with new CFL lamp

R5 - Clean and Relamp existing recessed wall washer with new CFL lamp



1.



2.



3.

Cambridge City Hall - Senior Center Ballroom

I. Executive Summary

Despite appropriate lighting levels for the various activities of the senior center ballroom, issues of efficiency and aesthetics, combined with related HVAC work, suggest that replacement of all lighting hardware is necessary.

II. Observations & Existing Conditions

The Senior Center Ballroom is currently illuminated with oversized pendant fixtures and recessed downlighting (see images to right). All current fixtures have been retro-fitted with compact fluorescent lamps which, although more efficient than incandescent, are relatively inefficient as a system. Current illumination levels of the space are appropriate for the variety of activities taking place. Lighting is not currently dimmable.

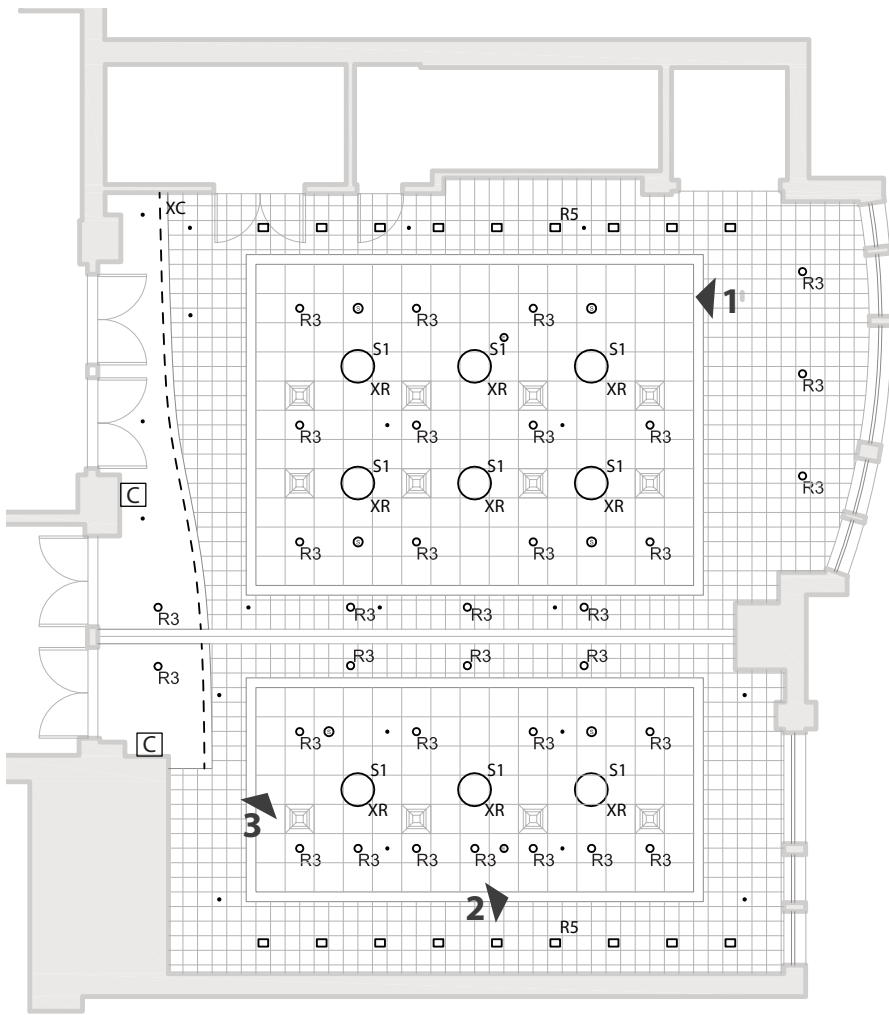
III. Recommendations

- The existing pendant fixtures are inappropriately scaled for the size and use of the Ballroom, and the ambient downlighting efficiency can be improved. For this reason it is suggested that all of the existing lighting in the ballroom be removed and, in the same locations, new dimmable downlights and dimmable ceiling surface fixtures be used in their place (S1 Drum fixture shown in image).
- With new LED-based lighting fixtures and dimmable controls, it is estimated that half of the energy will be used in this ballroom to achieve the current illuminance levels with more flexibility to accommodate program.
- To accommodate the City's desire for additional and improved projection capability, the new decorative fixtures must be closer to the ceiling plane so as not to interfere with the projected image.
- The existing banks of switches should be replaced with banks of wall-box dimmers, or a scene-based Lutron Grafik Eye system in same locations.

IV. Coordination

Coordination with AV consultant is important due to the proposed new/upgraded projection system. Mounting height and locations of replacement fixtures will be shared so projections are not obscured or otherwise interfered with. The two options for new controls (wall-box dimmers or preset system) should be decided based on ease of setup, and coordination with AV consultant for audio/video integration. Fixture locations should remain unchanged, but new surface-mounted S1 fixtures should be coordinated with existing utilities.

V. Additional Considerations



1.



2.



3.

XR/S1 - Existing pendant to be removed and replaced with new S1 fixture

XR/R3 - Existing downlight to be removed and replaced with new dimmable LED R3 downlight

XR/R5 - Existing washlight to be removed and replaced with new dimmable R5 LED washlight

XC - Existing fluorescent cove to be cleaned and relamped



S1 - Lumetta Decorative Drum

Cambridge City Hall - Lombardi Room

I. Executive Summary

The Lombardi meeting room has a very simple lighting approach, but some minor changes can improve the efficiency and feel of the space.

II. Observations & Existing Conditions

The existing lighting in the Lombardi meeting room consists of six 2x4 recessed fluorescent troffers and a few recessed downlights. These fluorescent troffers are parabolic-type which tend to be very inefficient and create a cavernous effect by focusing light downward. The fixtures are currently arranged unevenly on the north side of the room due perhaps to sprinkler location.

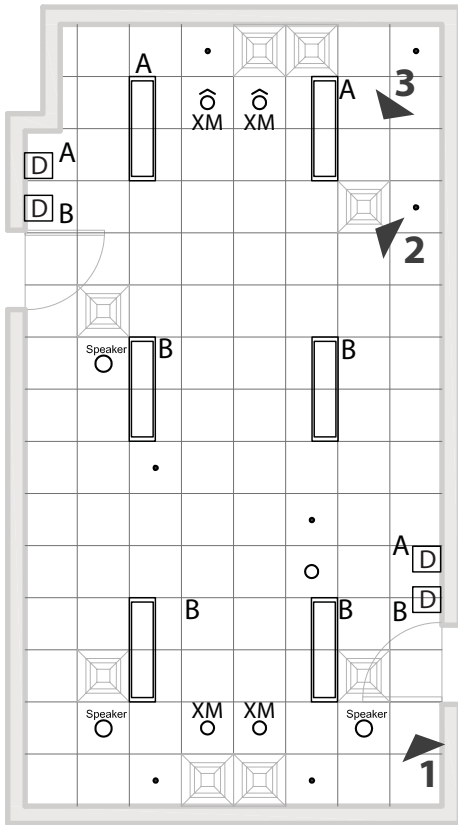
III. Recommendations

The existing parabolic fluorescent troffers should be replaced one for one with new volumetric-type fluorescent troffers that are much more efficient than the parabolic-type, and have a light distribution which will better illuminate the walls of the space. Additionally, these should be dimmable in two zones, with the random pattern of recessed downlights to be removed. New wall-box fluorescent dimmers will simply replace existing switches. An adjustment of the fixture layout will help better balance the room's lighting needs. Additionally, 1'x4' fixtures are proposed as an efficient and more aesthetically pleasing choice for the space.

IV. Coordination

The ceiling of the Lombardi room is very busy with light fixtures, speakers, sprinkler heads, and mechanical diffusers. The proposed new layout must be confirmed feasible with respect to any new HVAC work or modifications.

V. Additional Considerations



XM - Existing recessed downlights to be removed

XR/R6 - Existing 2x4 fluorescent troffers to be replaced with new dimmable volumetric 1x4 fluorescent troffers

D - New fluorescent 3-way wall box dimmer to control two R6 fixtures in the front of the room separately from 4 R6 fixtures in the center & rear of room



R6 - Lithonia 1' x 4' Volumetric Troffer



1.



2.



3.

Cambridge City Hall - City Hall Annex

I. Executive Summary

The City Hall Annex meeting room was renovated fairly recently and lighting recommendations consist of relamping and cleaning of existing fixtures, along with proposed switching that will improve functionality of the space.

II. Observations & Existing Conditions

The City hall Annex meeting room consists of several rows of similar downlights. The circuiting of the room does not currently work with the multiple uses of the space. The “front” of the room alternates between the wall opposite the entrance (for most public hearings), and the wall to the right of the entrance (for projected presentations).

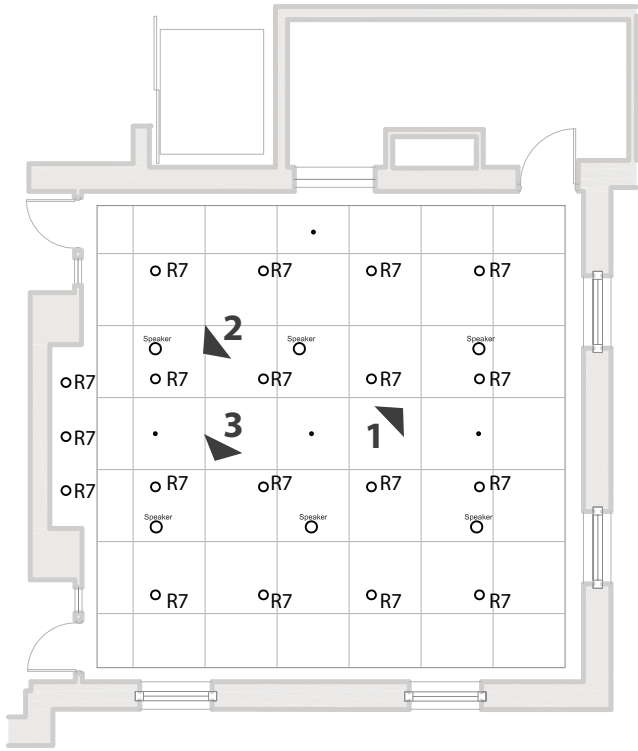
III. Recommendations

Considering how recently the Annex meeting room was updated, lighting recommendations for the space are limited. The approach to this room is to clean the existing downlights and washlights and replace the existing lamps with new 3000K compact fluorescent lamps of the same wattage. To respond to the circuiting issues the room has currently, a new scheme is proposed that allows for more flexibility depending on use. The proposed scheme will allow lighting at the back of the room during presentations (zone ‘A’ in circuit diagram), regardless of the location of presenters.

IV. Coordination

No additional lighting controls or AV integration are recommended at this time.

V. Additional Considerations



R7 - Clean and Relamp existing recessed downlight with new CFL lamp



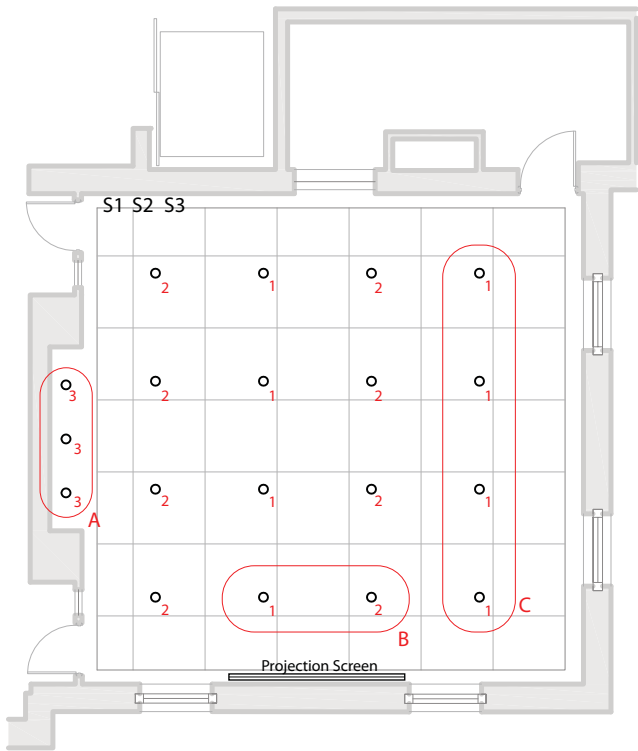
1.



2.



3.



Proposed Switching/Circuit Diagram
 -Allows for three separate zones to coincide with flexible presentation spaces.

Cambridge City Hall - Waterworks

I. Executive Summary

The Waterworks was renovated fairly recently and consists of relamping and cleaning of existing fixtures, along with making the downlight scheme dimmable and aim-able.

II. Observations & Existing Conditions

The Waterworks consists of multiple downlights and pendants, along with two linear uplights above the entry vestibule. The pendants and wall sconces currently use compact fluorescent lamps, while the downlights are metal halide lamps. There are no aim-able fixtures to highlight speakers if the space is to be used for functions or presentations.

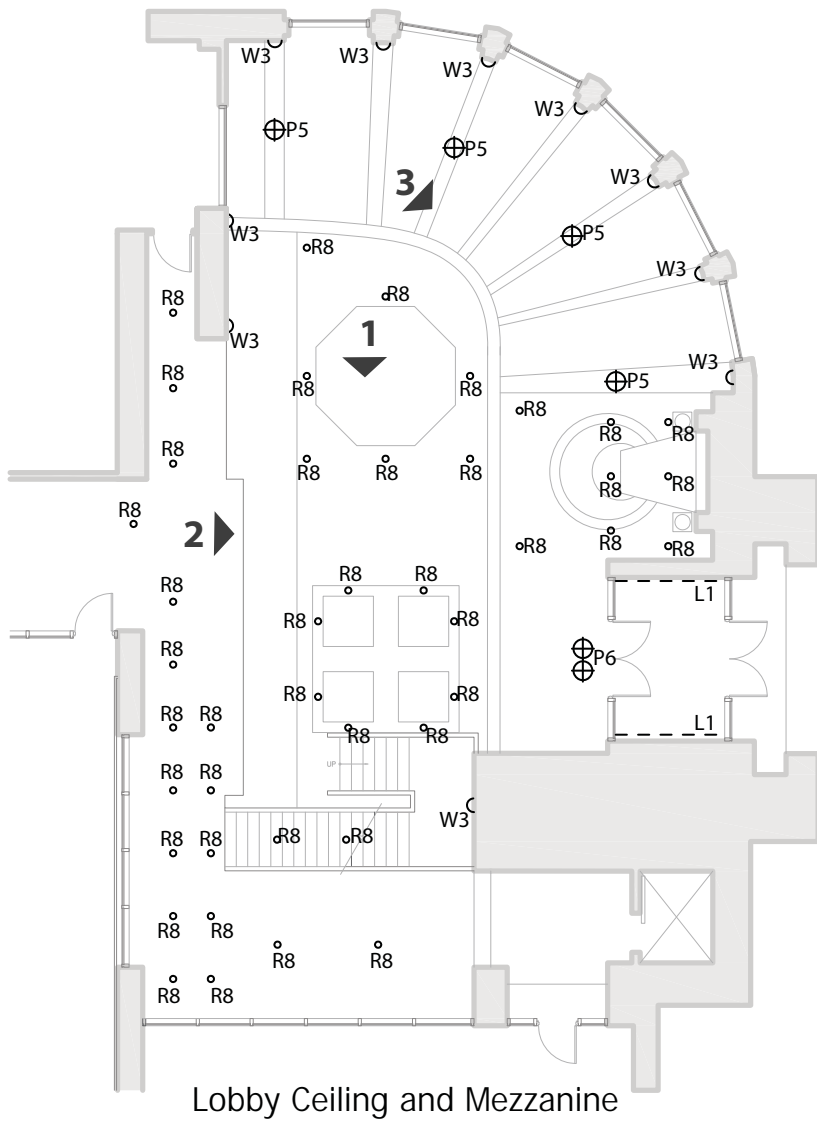
III. Recommendations

The Waterworks was recently renovated, so lighting recommendations are limited. The pendant fixtures and wall sconces should be cleaned and re-lamped, while the downlights should be dimmable and aim-able. Dimming isn't possible with the current metal halide lamps, so these would need to be relamped. Additionally, changing several of the upper level downlights to adjustable accent lights would allow for highlighting of speakers and presentations.

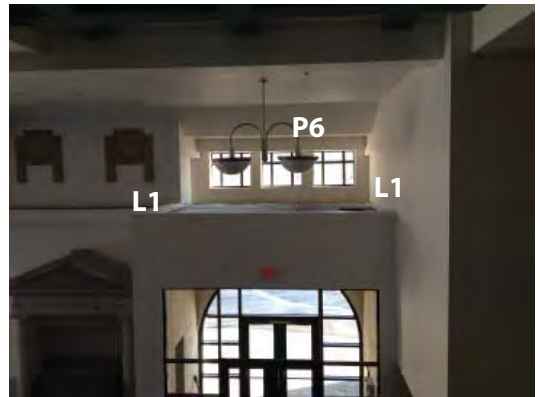
IV. Coordination

No additional lighting controls or AV integration are recommended at this time.

V. Additional Considerations



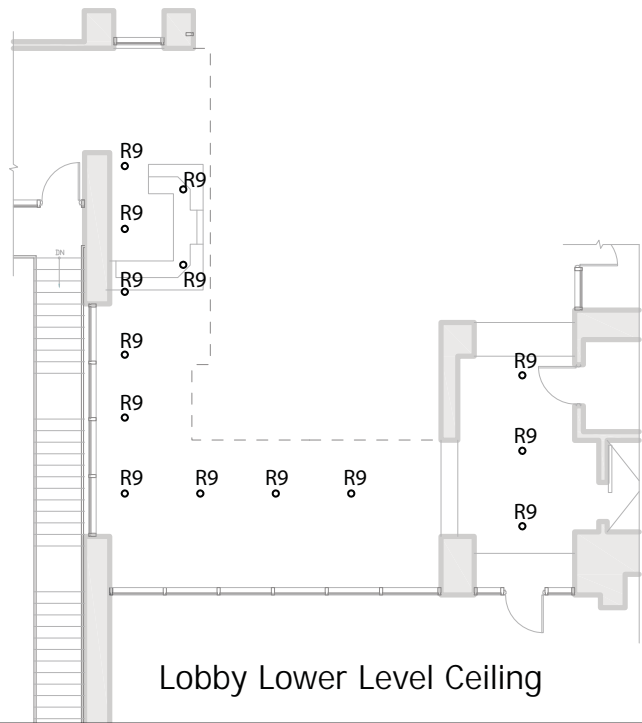
1.



2.



3.



R8 - Clean and Relamp existing recessed downlight with new CFL lamp

R9 - Clean and Relamp existing recessed downlight with new CFL lamp

P5 - Clean and Relamp existing Pendant fixture

P6 - Clean and Relamp existing Pendant fixture

W3 - Clean and Relamp existing wall sconces

L1 - Clean and Relamp existing linear uptlights

Limited Hazardous Building Materials Inspection

City of Cambridge Audiovisual Renovations
Cambridge City Hall, Cambridge Senior Center &
Michael J. Lombardi Municipal Building
Cambridge, MA

February 15, 2013

LDa Architects LLP
Cambridge, Massachusetts

February 21, 2013



Fuss & O'Neill EnviroScience, LLC
50 Redfield Street, Suite 100
Boston, Massachusetts 02122



FUSS & O'NEILL
EnviroScience, LLC

February 21, 2013

Mr. Matthew Simitis
LDa Architecture & Interiors
222 Third Street, Suite 3212
Cambridge, MA 02142

Re: **Limited Hazardous Building Materials Inspection**
City of Cambridge Audiovisual Renovations
Fuss & O'Neill EnviroScience No. 20121733.A1E

Dear Mr. Simitis:

On February 15, 2013, Fuss & O'Neill EnviroScience, LLC representatives, Jonathan Hand and Luigi Marangiello, performed a limited hazardous building materials inspection in response to proposed audiovisual renovations for the City of Cambridge.

Mr. Hand and Mr. Marangiello are licensed Asbestos Inspectors in the Commonwealth of Massachusetts. Eighty samples of suspect ACM were collected from five functional spaces (within three municipal buildings) including the following: Sullivan Chamber, Ackermann Room, and Sophie J. Anastos Conference Room (at Cambridge City Hall); Senior Center Ballroom (at Cambridge Senior Center); Lombardi Conference Room (at Michael J. Lombardi Municipal Building). Asbestos Containing Materials were analyzed at a certified laboratory by Polarized Light Microscopy (PLM). A lead-based paint screening was also performed at each of the abovementioned locations.

We have excluded collection and analysis of building materials for Polychlorinated biphenyls (PCB). Sampling in the above matrices is presently not mandated by the EPA; however, significant liability risk for disposing of PCB-containing wastes exists. Recent knowledge of PCBs within these matrices has become more prevalent especially with remediation contractors, waste haulers, and disposal facilities. Many property Owners have become subject to large changes in schedule, scope, and costs as a result of failure to identify this possible contaminant prior to renovation or demolition.

Note that inspection of the Cambridge City Hall Annex Building and Cambridge Water Works Building, which are included within scope of (audiovisual) renovation work, were excluded from this limited hazardous building materials inspection per request of Client. According to City of Cambridge, previous abatement activities removed all asbestos-containing building materials from interior of Cambridge City Hall Annex Building, and (newer) construction of Cambridge Water Works Building specified for use of non-asbestos building materials during construction.

50 Redfield Street
Suite 100
Boston, MA
02122
t (617) 282-4675
f (617) 282-8253

www.FandO.com

Connecticut
Massachusetts
Rhode Island
South Carolina



Furthermore, an inventory of PCB/DEHP-containing fluorescent ballasts and mercury-containing lamps was not included within the written scope of services. Superfund liability exists for landfilling both PCB and DEHP- containing light ballasts; these materials are considered hazardous waste under RCRA, and require special handling and disposal considerations. Moreover, mercury lamps are characterized as a Universal Waste (according to USEPA), and must be recycled or disposed of as hazardous waste. The scope of work relating to replacement of lighting fixtures and/or thermostatic controls was not known at the time of this inspection.

If you have any questions regarding the contents of this report, please do not hesitate to contact me at (617) 282-4675, extension 4703. Thank you for this opportunity to have served your environmental needs.

Sincerely,

Dustin A. Diedricksen
Project Manager/Senior Scientist

DAD/ftc

Enclosure

Table of Contents

Limited Hazardous Building Materials Inspection Report City of Cambridge Audiovisual Renovations LDa Architecture and Interiors

1	Introduction	1
2	Asbestos Inspection	1
	2.1 Results	2
	2.2 Discussion	4
	2.3 Conclusion	5
3	Lead-Based Paint Determination	5
	3.1 Results	6
	3.2 Discussion	7
	3.3 Conclusion	7

Appendices

APPENDIX A	- INSPECTOR LICENSES AND CERTIFICATIONS
APPENDIX B	- ASBESTOS SAMPLE RESULTS AND CHAIN OF CUSTODY
APPENDIX C	- TEM LABORATORY ANALYSIS RESULTS
APPENDIX D	- LEAD PAINT TESTING PROCEDURES AND EQUIPMENT
APPENDIX E	- LEAD TESTING FIELD DATA SHEETS
APPENDIX F	- HAZARDOUS MATERIALS ABATEMENT COST ESTIMATE

1 Introduction

On February 15, 2013, Fuss & O'Neill EnviroScience, LLC (EnviroScience) representatives, Jonathan Hand and Luigi Marangiello, performed a limited hazardous building material inspection in response to proposed audiovisual renovations for the City of Cambridge. The scope of work was limited to five functional spaces (within three municipal buildings) including the following: Sullivan Chamber, Ackermann Room, and Sophie J. Anastos Conference Room (at Cambridge City Hall); Senior Center Ballroom (at Cambridge Senior Center); Lombardi Conference Room (at Michael J. Lombardi Municipal Building).

The work was performed for LDa Architecture & Interiors in accordance with the revised scope of services dated February 11, 2013. The site inspection included a limited asbestos inspection and lead-based paint determination. Refer to *Appendix A* for a copy of each Asbestos Inspector license.

Note that inspection of the Cambridge City Hall Annex Building and Cambridge Water Works Building, which are included within scope of (audiovisual) renovation work, were excluded from this limited hazardous building materials inspection per request of Client. According to City of Cambridge, previous abatement activities removed all asbestos-containing building materials from interior of Cambridge City Hall Annex Building, and (newer) construction of Cambridge Water Works Building specified for use of non-asbestos building materials during construction.

2 Asbestos Inspection

A property Owner must ensure that performance of a thorough inspection for asbestos-containing materials (ACM) prior to possible disturbance of materials containing asbestos during renovation or demolition is conducted. This is a requirement of the U.S. Environmental Protection Agency (USEPA) National Emission Standards for Hazardous Air Pollutants (NESHAP) regulation 40 CFR Part 61, Sub-Part M.

This includes Friable, Non-Friable Category I, and Non-Friable Category II ACM.

A Friable Material is defined as material that contains greater than 1 percent asbestos, that when dry can be crumbled, pulverized, or reduced to powder by hand pressure.

A Category I Non-Friable Material refers to material that contains greater than 1 percent asbestos (e.g. packings, gaskets, resilient floor coverings, asphalt roofing products, etc.) that when dry cannot be crumbled, pulverized, or reduced to powder by hand pressure.

A Category II Non-Friable Material refers to any non-friable material (excluding Category I materials) that contains greater than 1 percent asbestos that when dry cannot be crumbled, pulverized, or reduced to powder by hand pressure.

Massachusetts Department of Environmental Protection (MassDEP) further defines the definition of asbestos-containing materials as any material containing 1 percent or more asbestos to be an ACM.

During this inspection, suspect asbestos-containing materials (ACM) were separated into three USEPA categories. These categories are Thermal System Insulation (TSI), Surfacing (SURF), and Miscellaneous (MISC). TSI includes all materials used to prevent heat loss/gain or water condensation on mechanical systems. Examples of TSI are pipe insulation, boiler insulation, duct insulation, and mudded insulation on pipe fittings.

Surfacing ACM includes all ACM that is sprayed, troweled, or otherwise applied to an existing surface. Surfacing ACM is commonly used for fireproofing, decorative, and acoustical applications. Miscellaneous materials include all ACM not listed as thermal or surfacing, such as linoleum, vinyl asbestos flooring, and ceiling tiles.

Samples are recommended to be collected in a manner sufficient to determine asbestos content and include homogenous building materials. The USEPA NESHAP regulation does not specifically identify a minimum number of samples to be collected, but recommends the use of sampling protocols included in 40 CFR Part 763, Sub-Part E - Asbestos Containing Materials in Schools.

Samples of suspect asbestos-containing materials were collected in accordance with United States Environmental Protection Agency (USEPA) recommendations and Asbestos Hazard Emergency Response Act (AHERA) protocols. The protocols included the following:

Surfacing Materials (SURF) such as plaster, spray-on fireproofing, etc. were collected in a randomly distributed manner representing each homogenous area based on the overall quantity represented by the sampling as follows:

- Three (3) samples collected from each homogenous area that is less than or equal to 1,000 square feet.
- Five (5) samples collected from each homogenous area that is greater than 1,000 square feet, but less than or equal to 5,000 square feet.
- Seven (7) samples collected from each homogenous area that is greater than 5,000 square feet.

Thermal System Insulation (TSI) (e.g. pipe insulation, tank insulation, etc.) was collected in a randomly distributed manner representing each homogenous area. Three (3) bulk samples were collected from each material and sent to laboratory for asbestos analysis. Also, a minimum of one (1) sample of any patching material (less than 6 linear of square feet) applied to TSI was collected.

Miscellaneous Materials (MISC) (e.g. floor tile, gaskets, construction mastics, etc.) had a minimum of two (2) samples collected as representative of each homogenous material type. Sampling was conducted in a manner sufficient to determine asbestos content of the homogenous material as determined by the Asbestos Inspector(s). If materials identified were of (significant) minimal quantity, only a single sample was collected.

The Asbestos Inspector(s) collected samples, and prepared proper chain of custody for transmission of samples to an accredited laboratory for analysis by Polarized Light Microscopy (PLM). Samples of all suspect ACM to be impacted by the renovations were collected. The sampling locations, material type, sample identification, and asbestos content are identified by bulk sample analysis in Tables 1 and 2 of the “Results” section. Any materials at the site not listed in the following tables should be considered suspect ACM until sample results prove otherwise. Refer to *Appendix B* for asbestos sample results.

2.1 Results

Utilizing the USEPA protocol and criteria, no materials were determined to be ACM.

Utilizing the USEPA protocol and criteria, the following materials were determined not to contain asbestos.

TABLE 1
Non-Asbestos Containing Materials

SAMPLED LOCATIONS	MATERIAL TYPE	SAMPLE NO.
Cambridge City Hall		
Sullivan Chamber	Decorative Plaster	0215LM-01 A-C
Sullivan Chamber	Curved Ceiling Skim Plaster	0215LM-02 A-C
Sullivan Chamber	Curved Ceiling Rough Plaster	0215LM-03 A-C
Sullivan Chamber	Wall Skim Plaster	0215LM-04 A-B
Sullivan Chamber	Wall Rough Plaster	0215LM-05 A-B
Sullivan Chamber	1x1 Ceiling Tile	0215LM-06 A-C
Sophie J. Anastos Conference Room	Pipe-Thread Sealant Associated with Radiator	0215LM-07 A-B
Sophie J. Anastos Conference Room	2x2 Textured Ceiling Tile	0215LM-08 A-B
Sophie J. Anastos Conference Room	Ceiling Rough Plaster	0215LM-09 A-C
Sophie J. Anastos Conference Room	Window Caulking	0215LM-10 A-B
Sophie J. Anastos Conference Room	Ceiling Skim Plaster	0215LM-11 A-C
Sophie J. Anastos Conference Room	Drywall	0215LM-12 A-C
Sophie J. Anastos Conference Room	Window Glazing Compound	0215LM-13 A-B
Sophie J. Anastos Conference Room	Joint Compound	0215LM-14 A-C
Sophie J. Anastos Conference Room	Carpet Glue/Leveling Compound*	0215LM-15 A-B
Ackermann Room	Interior Window Glazing Compound	0215LM-16 A-B
Ackermann Room	Wire Coating	0215LM-17 A-B
Michael J. Lombardi Municipal Building		
Lombardi Conference Room at Basement	Carpet Glue*	0215LM-18 A-B
Lombardi Conference Room at Basement	Joint Compound	0215LM-19 A-C
Lombardi Conference Room at Basement	Drywall	0215LM-20 A-C
Lombardi Conference Room at Basement	4" Blue Vinyl Baseboard*	0215LM-21 A-B
Lombardi Conference Room at Basement	Fissure & Dot Ceiling Tile	0215LM-22 A-B
Lombardi Conference Room at Basement	White Mastic Associated with 4" Blue Vinyl Baseboard*	0215LM-121 A-B

SAMPLED LOCATIONS	MATERIAL TYPE	SAMPLE NO.
Cambridge Senior Center		
Senior Center Ballroom	12x12 Floor Tile (at Perimeter)*	0215LM-23 A-C
Senior Center Ballroom	White 1x1 Ceiling Tile	0215LM-24 A-C
Senior Center Ballroom	Fissure & Dot 2x2 Ceiling Tile	0215LM-25 A-C
Senior Center Ballroom	Grey 2x2 Ceiling Tile	0215LM-26 A-C
Senior Center Ballroom	Brown 4" Vinyl Baseboard*	0215LM-27 A-C
Senior Center Ballroom	Joint Compound	0215LM-28 A-C
Senior Center Ballroom	Yellow Mastic Associated with 12x12 Floor Tile*	0215LM-29 A-C
Senior Center Ballroom	Drywall	0215LM-30 A-C

*Material type confirmed as non-asbestos by additional TEM analysis

Refer to *Appendix B* for laboratory analytical results.

2.2 Discussion

The USEPA, Occupational Safety and Health Administration (OSHA), and the Commonwealth of Massachusetts Department of Labor Standards (DLS), formerly known as the Division of Occupational Safety (DOS), defines any material that contains greater than one percent (>1%) asbestos, utilizing PLM, as being an ACM. The Commonwealth of Massachusetts Department of Environmental Protection (MassDEP) defines any material that contains equal to or greater than one percent ($\geq 1\%$) asbestos as being an ACM. Materials that are identified as "none detected" are specified as not containing asbestos.

The USEPA has suggested that materials that are non-friable organically bound materials (e.g. mastic adhesives, etc.) are recommended for further confirmatory analysis utilizing Transmission Electron Microscopy (TEM). Seven of the collected samples were analyzed by TEM, and the results of TEM analysis are provided below in Table 2.

TABLE 2
Materials Analyzed By TEM

SAMPLE LOCATION	MATERIAL TYPE	SAMPLE NO.	ASBESTOS CONTENT
Sophie J. Anastos Conference Room	Carpet Glue/Leveling Compound	0215LM-15A	None Detected
Lombardi Conference Room at Basement	Carpet Glue	0215LM-18A	<0.33% Chrysotile
Lombardi Conference Room at Basement	4" Blue Vinyl Baseboard	0215LM-21A	None Detected
Lombardi Conference Room at Basement	White Mastic Associated with 4" Blue Vinyl Baseboard	0215LM-121 A	None Detected
Senior Center Ballroom	12x12 Floor Tile (at Perimeter)	0215LM-23A	None Detected
Senior Center Ballroom	4" Vinyl Baseboard	0215LM-27A	None Detected

SAMPLE LOCATION	MATERIAL TYPE	SAMPLE NO.	ASBESTOS CONTENT
Senior Center Ballroom	Yellow Mastic Associated with 12x12 Floor Tile	0215LM-29	None Detected

The results of confirmatory analysis by TEM did not identify asbestos at 1% or greater for any of the seven analyzed materials. The materials have been included in Table 1 based on confirmatory analysis results. Refer to *Appendix C* for TEM analysis results.

2.3 Conclusion

All visible and accessible building materials that will be impacted by proposed audiovisual renovations have been determined to be non-asbestos. However, it must be assumed that suspect asbestos-containing materials are concealed underneath flooring (e.g. flooring felt, etc.) until proven otherwise. Note that testing of concealed materials was excluded from this feasibility study per request of Client. Therefore, additional testing for concealed materials (by means of selective demolition) may be authorized once final scope of work is determined. Alternatively, a licensed Asbestos Abatement Contractor shall make all floor penetrations (within mini-enclosure containment) as needed for installation of electrical conduits, heating risers, etc. if selective demolition is not authorized.

EnviroScience recommends that a comprehensive scope of work and technical specification be developed as part of renovation plans for the site. We have provided a cost to develop the specifications for inclusion in the overall renovation plans. We have also developed an opinion of cost for removal of hazardous building materials.

Any suspect material encountered during renovation/demolition that is not identified in this report as being non-ACM should be assumed to be ACM until sample results prove otherwise.

3 Lead-Based Paint Determination

A lead-based paint determination was performed for representative building components by Fuss & O'Neill EnviroScience, LLC (EnviroScience) representatives, Jonathan Hand and Luigi Marangiello, on February 15, 2013. An X-ray fluorescence (XRF) analyzer was used to perform the lead-based paint determination. The testing was conducted in accordance with the protocol outlined in the attached document: "Testing Procedures and Equipment" (*Appendix D*).

A Radiation Monitoring Device Model LPA-1, serial number 1395, was utilized for the lead-based paint determination. The instrument was checked for proper calibration prior to each use as detailed by the manufacturer and the Performance Characteristic Sheet (PCS) developed for the instruments.

For the purpose of this lead-based paint determination, representative building components were tested as part of this feasibility study. Of course, individual repainting efforts are not discoverable in such a limited program. Lead-based paint issues involving properties that are not residential are regulated to a limited degree for worker protection relating to paint-disturbing work activities and waste disposal.

Worker protection is regulated by OSHA regulations, as well as DLS regulations. These regulations involve air monitoring of workers to determine exposure levels when disturbing lead-containing paint. A lead-based paint determination cannot determine a safe level of lead, but is intended to provide guidance for implementing industry standards for lead in paint at identified locations. Contractors may then better determine exposure of workers to airborne lead by understanding the different concentrations of lead-based paint on representative components and surfaces. Air monitoring can then be performed during activities that disturb paint on representative surfaces.

The USEPA Resource Conservation and Recovery Act (RCRA), as well as MassDEP, regulate disposal of lead-containing waste. Waste materials containing lead that will be impacted during renovation or demolition and result in waste for disposal must be tested using the Toxicity Characteristic Leachate Procedure (TCLP) analysis if lead is determined to be present in non-residential buildings. A TCLP sample is a representative sample of the intended waste stream. The results are compared to a threshold value of 5.0 mg/L; a result exceeding this value is considered hazardous lead waste. If the result is below the established level, the material is not considered hazardous and may be disposed of as normal construction debris.

A level of lead-based paint exceeding 1.0 milligrams of lead per square centimeter (mg/cm²) is considered toxic or dangerous for compliance with residential standards. For purpose of this lead-based paint determination the level of 1.0 mg/cm² has been utilized as a threshold for areas where possible worker exposures may occur. The complete results of the lead-based paint determination are included in *Appendix E*.

3.1 Results

The lead-based paint determination indicated consistent painting trends associated with representative building components that may be impacted by possible renovation work. Painted components determined to contain levels of lead (greater than 1.0 mg/cm²) include the following:

TABLE 3
Lead Painted Building Components

LOCATION	ITEM	SUBSTRATE	READING (mg/cm ²)
Sullivan Chamber: Balcony	Walls	Plaster	>9.9
Sullivan Chamber: Balcony	Curved Ceiling	Plaster	>9.9
Sullivan Chamber: Balcony	Columns	Plaster	>9.9
Sullivan Chamber	Upper Walls	Plaster	-0.1->9.9
Sullivan Chamber	Radiator	Metal	1.1
Sullivan Chamber	Grate	Metal	8.7
Ackermann Room	Window Components	Metal	>9.9

3.2 Discussion

OSHA published a Lead in Construction Standard (OSHA Lead Standard) 29 CFR 1926.62 in May 1993. The OSHA Lead Standard has no set limit for the content of lead in paint below which the standards do not apply. The OSHA Lead Standards are task-based, and derived from airborne exposure and blood lead levels.

The results of this survey are intended to provide guidance to contractors for occupational exposure-control to lead. Building components containing lead levels above industry standards may cause exposures to lead above OSHA standards during demolition and renovation activities. A TCLP sample to characterize the expected waste that may result from possible selective demolition and/or renovation work was not collected as part of this inspection. It should be noted that metal building components may be recycled as scrap metal, and are exempt from TCLP sampling.

3.3 Conclusion

Contractors must be made aware that OSHA has not established a level of lead in a material below which 29 CFR 1926.62 does not apply. Contractors shall comply with exposure assessment criteria, interim worker protection, and other requirements of the regulation as necessary to protect workers during any renovation work that will impact lead paint.

Lead paint was found on plaster walls and ceiling within the Sullivan Chamber, and on few metal components, at the time of this inspection. Note that any future work involving surface preparation of the identified painted surfaces shall be performed in accordance with OSHA worker protection requirements.

The building is presently characterized as commercial property, which is not subject to the Department of Public Health Child Lead Poisoning Prevention Program (CLPPP) 105 CMR 460.000 regulations. The property may be renovated using procedures required in accordance with OSHA regulation 29 CFR 1926.62 and DLS Regulation 454 CMR 22.11. In addition, the building is not considered a “child occupied facility” and therefore not subject to lead safe renovation requirements of 454 CMR 22.11.


Disclaimer: *The information contained in the survey report concerning the presence or absence of lead paint does not constitute a comprehensive lead inspection in accordance with Commonwealth of Massachusetts regulations 105 CMR 460. The surfaces tested represent only a portion of those surfaces that would be tested to determine whether the premises are in compliance with the aforementioned regulations, which are specific to a child occupied residence only and not applicable to a building of this type and use.*

We have included a cost estimate for hazardous materials abatement in *Appendix F*.

Report prepared by Senior Environmental Technician, Luigi Marangiello.

Reviewed by:


Dustin A. Diedricksen
Project Manager/Senior Scientist


Robert L. May, Jr.
Vice President

Appendix A

Inspector Licenses and Certifications

Commonwealth of Massachusetts
Department of Labor Standards

Heather E. Rowe, Director

Asbestos Inspector



JONATHAN L. HAND

Eff. Date 02/23/12

Exp. Date 03/07/13

A1041945

Member of C.O.N.E.S.

NB

13



NB-RENEWAL



Commonwealth of Massachusetts
Department of Labor Standards

Heather E. Rowe, Director

Asbestos Inspector



LUIGI MARANGIELLO

Eff. Date 01/10/13

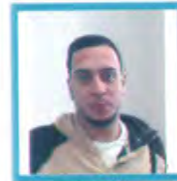
Exp. Date 01/10/14

A1900486

Member of C.O.N.E.S.

NBN

14



NB-NEW



Appendix B

Asbestos Sample Results and Chain of Custody



EMSL Analytical, Inc.

7 Constitution Way, Suite 107, Woburn, MA 01801

Phone/Fax: (781) 933-8411 / (781) 933-8412

bostonlab@emsl.com

EMSL Order: 131300630

CustomerID: ENVI54

CustomerPO:

ProjectID:

Attn: **Dustin Diedricksen**
Fuss & O'Neill EnviroScience, LLC
146 Hartford Road
Manchester, CT 06040

Phone: (860) 646-2469
Fax: (888) 838-1160
Received: 02/18/13 11:55 AM
Analysis Date: 2/19/2013
Collected: 2/15/2013

Project: **20121733.A1E / Cambridge City Hall; LDA Architects & Interiors; City Hall; 795 Massachusetts Ave; Cambridge, MA**

Test Report: Asbestos Analysis of Bulk Materials via EPA 600/R-93/116 and/or EPA 600/M4-82-020 Method(s) using Polarized Light Microscopy

Sample	Description	Appearance	Non-Asbestos		Asbestos
			% Fibrous	% Non-Fibrous	% Type
0215LM-01A <i>131300630-0001</i>	Sullivan Chamber - Decorative Plaster	White Non-Fibrous Homogeneous		100% Non-fibrous (other)	None Detected
0215LM-01B <i>131300630-0002</i>	Sullivan Chamber - Decorative Plaster	White Non-Fibrous Homogeneous		100% Non-fibrous (other)	None Detected
0215LM-01C <i>131300630-0003</i>	Sullivan Chamber - Decorative Plaster	White Non-Fibrous Heterogeneous		100% Non-fibrous (other)	None Detected
0215LM-02A <i>131300630-0004</i>	Sullivan Chamber - Curved Ceiling Skim	White Non-Fibrous Homogeneous		100% Non-fibrous (other)	None Detected
0215LM-02B <i>131300630-0005</i>	Sullivan Chamber - Curved Ceiling Skim	White Non-Fibrous Homogeneous		100% Non-fibrous (other)	None Detected
0215LM-02C <i>131300630-0006</i>	Sullivan Chamber - Curved Ceiling Skim	White Non-Fibrous Heterogeneous		100% Non-fibrous (other)	None Detected
0215LM-03A <i>131300630-0007</i>	Sullivan Chamber - Curved Ceiling Rough Coat	Gray Fibrous Homogeneous	2% Hair	98% Non-fibrous (other)	None Detected
0215LM-03B <i>131300630-0008</i>	Sullivan Chamber - Curved Ceiling Rough Coat	Gray Fibrous Homogeneous	2% Hair	98% Non-fibrous (other)	None Detected

Analyst(s)

Renaldo Drakes (31)

Steve Grise (49)

Renaldo Drakes, Laboratory Manager
or other approved signatory

EMSL maintains liability limited to cost of analysis. This report relates only to the samples reported and may not be reproduced, except in full, without written approval by EMSL. EMSL bears no responsibility for sample collection activities or analytical method limitations. Interpretation and use of test results are the responsibility of the client. This report must not be used by the client to claim product certification, approval, or endorsement by NVLAP, NIST or any agency of the federal government. Non-friable organically bound materials present a problem matrix and therefore EMSL recommends gravimetric reduction prior to analysis. Samples received in good condition unless otherwise noted. Estimated accuracy, precision and uncertainty data available upon request. Unless requested by the client, building materials manufactured with multiple layers (i.e. linoleum, wallboard, etc.) are reported as a single sample. Reporting limit is 1%
Samples analyzed by EMSL Analytical, Inc. Woburn, MA NVLAP Lab Code 101147-0, CT PH-0315, MA AA000188, RI AAL-10773 and VT AL357102

Initial report from 02/19/2013 15:04:23



EMSL Analytical, Inc.

7 Constitution Way, Suite 107, Woburn, MA 01801

Phone/Fax: (781) 933-8411 / (781) 933-8412

bostonlab@emsl.com

EMSL Order: 131300630

CustomerID: ENVI54

CustomerPO:

ProjectID:

Attn: **Dustin Diedricksen**
Fuss & O'Neill EnviroScience, LLC
146 Hartford Road
Manchester, CT 06040

Phone: (860) 646-2469
Fax: (888) 838-1160
Received: 02/18/13 11:55 AM
Analysis Date: 2/19/2013
Collected: 2/15/2013

Project: **20121733.A1E / Cambridge City Hall; LDA Architects & Interiors; City Hall; 795 Massachusetts Ave; Cambridge, MA**

Test Report: Asbestos Analysis of Bulk Materials via EPA 600/R-93/116 and/or EPA 600/M4-82-020 Method(s) using Polarized Light Microscopy

Sample	Description	Appearance	Non-Asbestos		Asbestos
			% Fibrous	% Non-Fibrous	% Type
0215LM-03C 131300630-0009	Sullivan Chamber - Curved Ceiling Rough Coat	Gray Non-Fibrous Heterogeneous		100% Non-fibrous (other)	None Detected
0215LM-04A 131300630-0010	Sullivan Chamber - Wall Skim Plaster	White Non-Fibrous Homogeneous		100% Non-fibrous (other)	None Detected
0215LM-04B 131300630-0011	Sullivan Chamber - Wall Skim Plaster	White Non-Fibrous Heterogeneous		100% Non-fibrous (other)	None Detected
0215LM-05A 131300630-0012	Sullivan Chamber - Wall Plaster Rough Coat	Gray Non-Fibrous Homogeneous	<1% Hair	100% Non-fibrous (other)	None Detected
0215LM-05B 131300630-0013	Sullivan Hall - Wall Plaster Rough Coat	White Non-Fibrous Heterogeneous		100% Non-fibrous (other)	None Detected
0215LM-06A 131300630-0014	Sullivan Hall - Ceiling Tile	Brown Fibrous Homogeneous	85% Cellulose	15% Non-fibrous (other)	None Detected
0215LM-06B 131300630-0015	Sullivan Hall - Ceiling Tile	Brown Fibrous Homogeneous	85% Cellulose	15% Non-fibrous (other)	None Detected
0215LM-06C 131300630-0016	Sullivan Hall - Ceiling Tile	Brown Fibrous Heterogeneous	98% Cellulose	2% Non-fibrous (other)	None Detected

Analyst(s)

Renaldo Drakes (31)

Steve Grise (49)

Renaldo Drakes, Laboratory Manager
or other approved signatory

EMSL maintains liability limited to cost of analysis. This report relates only to the samples reported and may not be reproduced, except in full, without written approval by EMSL. EMSL bears no responsibility for sample collection activities or analytical method limitations. Interpretation and use of test results are the responsibility of the client. This report must not be used by the client to claim product certification, approval, or endorsement by NVLAP, NIST or any agency of the federal government. Non-friable organically bound materials present a problem matrix and therefore EMSL recommends gravimetric reduction prior to analysis. Samples received in good condition unless otherwise noted. Estimated accuracy, precision and uncertainty data available upon request. Unless requested by the client, building materials manufactured with multiple layers (i.e. linoleum, wallboard, etc.) are reported as a single sample. Reporting limit is 1%
Samples analyzed by EMSL Analytical, Inc. Woburn, MA NVLAP Lab Code 101147-0, CT PH-0315, MA AA000188, RI AAL-10773 and VT AL357102

Initial report from 02/19/2013 15:04:23



EMSL Analytical, Inc.

7 Constitution Way, Suite 107, Woburn, MA 01801

Phone/Fax: (781) 933-8411 / (781) 933-8412

bostonlab@emsl.com

EMSL Order: 131300630

CustomerID: ENVI54

CustomerPO:

ProjectID:

Attn: **Dustin Diedricksen**
Fuss & O'Neill EnviroScience, LLC
146 Hartford Road
Manchester, CT 06040

Phone: (860) 646-2469
Fax: (888) 838-1160
Received: 02/18/13 11:55 AM
Analysis Date: 2/19/2013
Collected: 2/15/2013

Project: **20121733.A1E / Cambridge City Hall; LDA Architects & Interiors; City Hall; 795 Massachusetts Ave; Cambridge, MA**

Test Report: Asbestos Analysis of Bulk Materials via EPA 600/R-93/116 and/or EPA 600/M4-82-020 Method(s) using Polarized Light Microscopy

Sample	Description	Appearance	Non-Asbestos		Asbestos
			% Fibrous	% Non-Fibrous	% Type
0215LM-07A 131300630-0017	Sophie Anastos Room - Pipe Thread Sealant	Tan Non-Fibrous Homogeneous		100% Non-fibrous (other)	None Detected
0215LM-07B 131300630-0018	Sophie Anastos Room - Pipe Thread Sealant	Brown Non-Fibrous Homogeneous	<1% Fibrous (other)	100% Non-fibrous (other)	None Detected
0215LM-08A 131300630-0019	Sophie Anastos - Textured Ceiling Tile	Gray/W white Fibrous Homogeneous	35% Cellulose 35% Min. Wool	30% Non-fibrous (other)	None Detected
0215LM-08B 131300630-0020	Sophie Anastos - Textured Ceiling Tile	Gray Fibrous Homogeneous	45% Cellulose 40% Glass	15% Non-fibrous (other)	None Detected
0215LM-09A 131300630-0021	Sophie Anastos - Ceiling Rough Coat	Gray Non-Fibrous Homogeneous		100% Non-fibrous (other)	None Detected
0215LM-09B 131300630-0022	Sophie Anastos - Ceiling Rough Coat	Gray Non-Fibrous Homogeneous		100% Non-fibrous (other)	None Detected
0215LM-09C 131300630-0023	Sophie Anastos - Ceiling Rough Coat	Gray Non-Fibrous Heterogeneous		100% Non-fibrous (other)	None Detected
0215LM-10A 131300630-0024	Sophie Anastos - Window Caulking	Gray Non-Fibrous Homogeneous		100% Non-fibrous (other)	None Detected

Analyst(s)

Renaldo Drakes (31)

Steve Grise (49)

Renaldo Drakes, Laboratory Manager
or other approved signatory

EMSL maintains liability limited to cost of analysis. This report relates only to the samples reported and may not be reproduced, except in full, without written approval by EMSL. EMSL bears no responsibility for sample collection activities or analytical method limitations. Interpretation and use of test results are the responsibility of the client. This report must not be used by the client to claim product certification, approval, or endorsement by NVLAP, NIST or any agency of the federal government. Non-friable organically bound materials present a problem matrix and therefore EMSL recommends gravimetric reduction prior to analysis. Samples received in good condition unless otherwise noted. Estimated accuracy, precision and uncertainty data available upon request. Unless requested by the client, building materials manufactured with multiple layers (i.e. linoleum, wallboard, etc.) are reported as a single sample. Reporting limit is 1%
Samples analyzed by EMSL Analytical, Inc. Woburn, MA NVLAP Lab Code 101147-0, CT PH-0315, MA AA000188, RI AAL-10773 and VT AL357102

Initial report from 02/19/2013 15:04:23



EMSL Analytical, Inc.

7 Constitution Way, Suite 107, Woburn, MA 01801

Phone/Fax: (781) 933-8411 / (781) 933-8412

bostonlab@emsl.com

EMSL Order: 131300630

CustomerID: ENVI54

CustomerPO:

ProjectID:

Attn: **Dustin Diedricksen**
Fuss & O'Neill EnviroScience, LLC
146 Hartford Road
Manchester, CT 06040

Phone: (860) 646-2469
Fax: (888) 838-1160
Received: 02/18/13 11:55 AM
Analysis Date: 2/19/2013
Collected: 2/15/2013

Project: **20121733.A1E / Cambridge City Hall; LDA Architects & Interiors; City Hall; 795 Massachusetts Ave; Cambridge, MA**

Test Report: Asbestos Analysis of Bulk Materials via EPA 600/R-93/116 and/or EPA 600/M4-82-020 Method(s) using Polarized Light Microscopy

Sample	Description	Appearance	Non-Asbestos		Asbestos
			% Fibrous	% Non-Fibrous	% Type
0215LM-10B 131300630-0025	Sophie Anastos - Window Caulking	Gray Non-Fibrous Heterogeneous		100% Non-fibrous (other)	None Detected
0215LM-11A 131300630-0026	Sophie Anastos - Ceiling Skim	White Non-Fibrous Homogeneous		100% Non-fibrous (other)	None Detected
0215LM-11B 131300630-0027	Sophie Anastos - Ceiling Skim	White Non-Fibrous Homogeneous		100% Non-fibrous (other)	None Detected
0215LM-11C 131300630-0028	Sophie Anastos - Ceiling Skim	White Non-Fibrous Heterogeneous		100% Non-fibrous (other)	None Detected
0215LM-12A 131300630-0029	Sophie Anastos - Drywall	Gray Non-Fibrous Homogeneous	5% Cellulose	95% Non-fibrous (other)	None Detected
0215LM-12B 131300630-0030	Sophie Anastos - Drywall	Gray Non-Fibrous Homogeneous	5% Cellulose	95% Non-fibrous (other)	None Detected
0215LM-12C 131300630-0031	Sophie Anastos - Drywall	White Non-Fibrous Heterogeneous		100% Non-fibrous (other)	None Detected
0215LM-13A 131300630-0032	Sophie Anastos - Window Glazing Compound	White Non-Fibrous Homogeneous		100% Non-fibrous (other)	None Detected

Analyst(s)

Renaldo Drakes (31)

Steve Grise (49)

Renaldo Drakes, Laboratory Manager
or other approved signatory

EMSL maintains liability limited to cost of analysis. This report relates only to the samples reported and may not be reproduced, except in full, without written approval by EMSL. EMSL bears no responsibility for sample collection activities or analytical method limitations. Interpretation and use of test results are the responsibility of the client. This report must not be used by the client to claim product certification, approval, or endorsement by NVLAP, NIST or any agency of the federal government. Non-friable organically bound materials present a problem matrix and therefore EMSL recommends gravimetric reduction prior to analysis. Samples received in good condition unless otherwise noted. Estimated accuracy, precision and uncertainty data available upon request. Unless requested by the client, building materials manufactured with multiple layers (i.e. linoleum, wallboard, etc.) are reported as a single sample. Reporting limit is 1%
Samples analyzed by EMSL Analytical, Inc. Woburn, MA NVLAP Lab Code 101147-0, CT PH-0315, MA AA000188, RI AAL-10773 and VT AL357102

Initial report from 02/19/2013 15:04:23

**EMSL Analytical, Inc.**

7 Constitution Way, Suite 107, Woburn, MA 01801

Phone/Fax: (781) 933-8411 / (781) 933-8412

bostonlab@emsl.com

EMSL Order: 131300630

CustomerID: ENVI54

CustomerPO:

ProjectID:

Attn: **Dustin Diedricksen**
Fuss & O'Neill EnviroScience, LLC
146 Hartford Road
Manchester, CT 06040

Phone: (860) 646-2469
 Fax: (888) 838-1160
 Received: 02/18/13 11:55 AM
 Analysis Date: 2/19/2013
 Collected: 2/15/2013

Project: 20121733.A1E / Cambridge City Hall; LDA Architects & Interiors; City Hall; 795 Massachusetts Ave; Cambridge, MA

Test Report: Asbestos Analysis of Bulk Materials via EPA 600/R-93/116 and/or EPA 600/M4-82-020 Method(s) using Polarized Light Microscopy

Sample	Description	Appearance	Non-Asbestos		Asbestos
			% Fibrous	% Non-Fibrous	% Type
0215LM-13B 131300630-0033	Sophie Anastos - Window Glazing Compound	White Non-Fibrous Heterogeneous		100% Non-fibrous (other)	None Detected
0215LM-14A 131300630-0034	Sophie Anastos - Joint Compound	White Non-Fibrous Homogeneous		100% Non-fibrous (other)	None Detected
0215LM-14B 131300630-0035	Sophie Anastos - Joint Compound	White Non-Fibrous Homogeneous		100% Non-fibrous (other)	None Detected
0215LM-14C 131300630-0036	Sophie Anastos - Joint Compound	White Non-Fibrous Heterogeneous		100% Non-fibrous (other)	None Detected
0215LM-15A 131300630-0037	Sophie Anastos - Carpet Glue - Leveling Compound	Gray/Yellow Non-Fibrous Heterogeneous		100% Non-fibrous (other)	None Detected
0215LM-15B 131300630-0038	Sophie Anastos - Carpet Glue - Leveling Compound	Yellow Non-Fibrous Homogeneous		100% Non-fibrous (other)	None Detected
0215LM-16A 131300630-0039	Ackermann - Interior Window Glazing Compound	Gray Non-Fibrous Homogeneous		100% Non-fibrous (other)	None Detected
0215LM-16B 131300630-0040	Ackermann - Interior Window Glazing Compound	Gray Non-Fibrous Heterogeneous		100% Non-fibrous (other)	None Detected

Analyst(s)

Renaldo Drakes (31)

Steve Grise (49)

Renaldo Drakes, Laboratory Manager
or other approved signatory

EMSL maintains liability limited to cost of analysis. This report relates only to the samples reported and may not be reproduced, except in full, without written approval by EMSL. EMSL bears no responsibility for sample collection activities or analytical method limitations. Interpretation and use of test results are the responsibility of the client. This report must not be used by the client to claim product certification, approval, or endorsement by NVLAP, NIST or any agency of the federal government. Non-friable organically bound materials present a problem matrix and therefore EMSL recommends gravimetric reduction prior to analysis. Samples received in good condition unless otherwise noted. Estimated accuracy, precision and uncertainty data available upon request. Unless requested by the client, building materials manufactured with multiple layers (i.e. linoleum, wallboard, etc.) are reported as a single sample. Reporting limit is 1%
 Samples analyzed by EMSL Analytical, Inc. Woburn, MA NVLAP Lab Code 101147-0, CT PH-0315, MA AA000188, RI AAL-10773 and VT AL357102

Initial report from 02/19/2013 15:04:23



EMSL Analytical, Inc.

7 Constitution Way, Suite 107, Woburn, MA 01801

Phone/Fax: (781) 933-8411 / (781) 933-8412

bostonlab@emsl.com

EMSL Order: 131300630

CustomerID: ENVI54

CustomerPO:

ProjectID:

Attn: **Dustin Diedricksen**
Fuss & O'Neill EnviroScience, LLC
146 Hartford Road
Manchester, CT 06040

Phone: (860) 646-2469
Fax: (888) 838-1160
Received: 02/18/13 11:55 AM
Analysis Date: 2/19/2013
Collected: 2/15/2013

Project: **20121733.A1E / Cambridge City Hall; LDA Architects & Interiors; City Hall; 795 Massachusetts Ave; Cambridge, MA**

Test Report: Asbestos Analysis of Bulk Materials via EPA 600/R-93/116 and/or EPA 600/M4-82-020 Method(s) using Polarized Light Microscopy

Sample	Description	Appearance	Non-Asbestos		Asbestos
			% Fibrous	% Non-Fibrous	% Type
0215LM-17A 131300630-0041	Ackermann - Wire Coating	Brown Fibrous Homogeneous	98% Cellulose	2% Non-fibrous (other)	None Detected
0215LM-17B 131300630-0042	Ackermann - Wire Coating	Brown Fibrous Heterogeneous	95% Cellulose	5% Non-fibrous (other)	None Detected
0215LM-18A 131300630-0043	Lombardi - Black & Yellow Carpet Glue	Black/Yellow Non-Fibrous Heterogeneous		100% Non-fibrous (other)	None Detected
0215LM-18B 131300630-0044	Lombardi - Black & Yellow Carpet Glue	Black Non-Fibrous Homogeneous		100% Non-fibrous (other)	None Detected
0215LM-19A 131300630-0045	Lombardi - Joint Compound	White Non-Fibrous Homogeneous		100% Non-fibrous (other)	None Detected
0215LM-19B 131300630-0046	Lombardi - Joint Compound	White Non-Fibrous Homogeneous		100% Non-fibrous (other)	None Detected
0215LM-19C 131300630-0047	Lombardi - Joint Compound	White Non-Fibrous Heterogeneous		100% Non-fibrous (other)	None Detected
0215LM-20A 131300630-0048	Lombardi - Drywall	Gray/Tan Fibrous Heterogeneous	15% Cellulose	85% Non-fibrous (other)	None Detected

Analyst(s)

Renaldo Drakes (31)

Steve Grise (49)

Renaldo Drakes, Laboratory Manager
or other approved signatory

EMSL maintains liability limited to cost of analysis. This report relates only to the samples reported and may not be reproduced, except in full, without written approval by EMSL. EMSL bears no responsibility for sample collection activities or analytical method limitations. Interpretation and use of test results are the responsibility of the client. This report must not be used by the client to claim product certification, approval, or endorsement by NVLAP, NIST or any agency of the federal government. Non-friable organically bound materials present a problem matrix and therefore EMSL recommends gravimetric reduction prior to analysis. Samples received in good condition unless otherwise noted. Estimated accuracy, precision and uncertainty data available upon request. Unless requested by the client, building materials manufactured with multiple layers (i.e. linoleum, wallboard, etc.) are reported as a single sample. Reporting limit is 1%
Samples analyzed by EMSL Analytical, Inc. Woburn, MA NVLAP Lab Code 101147-0, CT PH-0315, MA AA000188, RI AAL-10773 and VT AL357102

Initial report from 02/19/2013 15:04:23



EMSL Analytical, Inc.

7 Constitution Way, Suite 107, Woburn, MA 01801

Phone/Fax: (781) 933-8411 / (781) 933-8412

bostonlab@emsl.com

EMSL Order:	131300630
CustomerID:	ENVI54
CustomerPO:	
ProjectID:	

Attn: **Dustin Diedricksen**
Fuss & O'Neill EnviroScience, LLC
146 Hartford Road
Manchester, CT 06040


Phone: (860) 646-2469
 Fax: (888) 838-1160
 Received: 02/18/13 11:55 AM
 Analysis Date: 2/19/2013
 Collected: 2/15/2013

Project: 20121733.A1E / Cambridge City Hall; LDA Architects & Interiors; City Hall; 795 Massachusetts Ave; Cambridge, MA

Test Report: Asbestos Analysis of Bulk Materials via EPA 600/R-93/116 and/or EPA 600/M4-82-020 Method(s) using Polarized Light Microscopy

Sample	Description	Appearance	Non-Asbestos		Asbestos
			% Fibrous	% Non-Fibrous	% Type
0215LM-20B 131300630-0049	Lombardi - Drywall	Gray/Tan Fibrous Heterogeneous	15% Cellulose	85% Non-fibrous (other)	None Detected
0215LM-20C 131300630-0050	Lombardi - Drywall	White Fibrous Heterogeneous	10% Cellulose	90% Non-fibrous (other)	None Detected
0215LM-21A 131300630-0051	Lombardi - 4" Blue Vinyl Baseboard	Blue Non-Fibrous Homogeneous		100% Non-fibrous (other)	None Detected
0215LM-21B 131300630-0052	Lombardi - 4" Blue Vinyl Baseboard	Blue Non-Fibrous Homogeneous		100% Non-fibrous (other)	None Detected
0215LM-22A 131300630-0053	Lombardi - Ceiling Tile	Gray/White Fibrous Homogeneous	35% Cellulose 35% Min. Wool	30% Non-fibrous (other)	None Detected
0215LM-22B 131300630-0054	Lombardi - Ceiling Tile	Brown Fibrous Heterogeneous	35% Cellulose 35% Glass	30% Non-fibrous (other)	None Detected
0215LM-23A 131300630-0055	Senior Center Ballroom - 12x12 Floor Tile	Beige Non-Fibrous Homogeneous		100% Non-fibrous (other)	None Detected
0215LM-23B 131300630-0056	Senior Center Ballroom - 12x12 Floor Tile	Beige Non-Fibrous Homogeneous		100% Non-fibrous (other)	None Detected

Analyst(s)
 Renaldo Drakes (31)
 Steve Grise (49)


 Renaldo Drakes, Laboratory Manager
 or other approved signatory

EMSL maintains liability limited to cost of analysis. This report relates only to the samples reported and may not be reproduced, except in full, without written approval by EMSL. EMSL bears no responsibility for sample collection activities or analytical method limitations. Interpretation and use of test results are the responsibility of the client. This report must not be used by the client to claim product certification, approval, or endorsement by NVLAP, NIST or any agency of the federal government. Non-friable organically bound materials present a problem matrix and therefore EMSL recommends gravimetric reduction prior to analysis. Samples received in good condition unless otherwise noted. Estimated accuracy, precision and uncertainty data available upon request. Unless requested by the client, building materials manufactured with multiple layers (i.e. linoleum, wallboard, etc.) are reported as a single sample. Reporting limit is 1%
 Samples analyzed by EMSL Analytical, Inc. Woburn, MA NVLAP Lab Code 101147-0, CT PH-0315, MA AA000188, RI AAL-10773 and VT AL357102

Initial report from 02/19/2013 15:04:23



EMSL Analytical, Inc.

7 Constitution Way, Suite 107, Woburn, MA 01801

Phone/Fax: (781) 933-8411 / (781) 933-8412

bostonlab@emsl.com

EMSL Order: 131300630

CustomerID: ENVI54

CustomerPO:

ProjectID:

Attn: **Dustin Diedricksen**
Fuss & O'Neill EnviroScience, LLC
146 Hartford Road
Manchester, CT 06040

Phone: (860) 646-2469
Fax: (888) 838-1160
Received: 02/18/13 11:55 AM
Analysis Date: 2/19/2013
Collected: 2/15/2013

Project: **20121733.A1E / Cambridge City Hall; LDA Architects & Interiors; City Hall; 795 Massachusetts Ave; Cambridge, MA**

Test Report: Asbestos Analysis of Bulk Materials via EPA 600/R-93/116 and/or EPA 600/M4-82-020 Method(s) using Polarized Light Microscopy

Sample	Description	Appearance	Non-Asbestos		Asbestos
			% Fibrous	% Non-Fibrous	% Type
0215LM-23C 131300630-0057	Senior Center Ballroom - 12x12 Floor Tile	White Non-Fibrous Heterogeneous		100% Non-fibrous (other)	None Detected
0215LM-24A 131300630-0058	Senior Center Ballroom - 1x1 Ceiling Tile; White	Gray/White Fibrous Homogeneous	35% Cellulose 35% Min. Wool	30% Non-fibrous (other)	None Detected
0215LM-24B 131300630-0059	Senior Center Ballroom - 1x1 Ceiling Tile; White	Gray/White Fibrous Homogeneous	35% Cellulose 35% Min. Wool	30% Non-fibrous (other)	None Detected
0215LM-24C 131300630-0060	Senior Center Ballroom - 1x1 Ceiling Tile; White	Gray Non-Fibrous Heterogeneous	40% Cellulose 35% Glass	25% Non-fibrous (other)	None Detected
0215LM-25A 131300630-0061	Senior Center Ballroom - Fissure & Dot 2x2 Ceiling Tile	Gray/White Fibrous Homogeneous	35% Cellulose 35% Min. Wool	30% Non-fibrous (other)	None Detected
0215LM-25B 131300630-0062	Senior Center Ballroom - Fissure & Dot 2x2 Ceiling Tile	Gray/White Fibrous Homogeneous	35% Cellulose 35% Min. Wool	30% Non-fibrous (other)	None Detected
0215LM-25C 131300630-0063	Senior Center Ballroom - Fissure & Dot 2x2 Ceiling Tile	Gray Fibrous Heterogeneous	40% Cellulose 35% Glass	25% Non-fibrous (other)	None Detected

Analyst(s)

Renaldo Drakes (31)

Steve Grise (49)

Renaldo Drakes, Laboratory Manager
or other approved signatory

EMSL maintains liability limited to cost of analysis. This report relates only to the samples reported and may not be reproduced, except in full, without written approval by EMSL. EMSL bears no responsibility for sample collection activities or analytical method limitations. Interpretation and use of test results are the responsibility of the client. This report must not be used by the client to claim product certification, approval, or endorsement by NVLAP, NIST or any agency of the federal government. Non-friable organically bound materials present a problem matrix and therefore EMSL recommends gravimetric reduction prior to analysis. Samples received in good condition unless otherwise noted. Estimated accuracy, precision and uncertainty data available upon request. Unless requested by the client, building materials manufactured with multiple layers (i.e. linoleum, wallboard, etc.) are reported as a single sample. Reporting limit is 1%
Samples analyzed by EMSL Analytical, Inc. Woburn, MA NVLAP Lab Code 101147-0, CT PH-0315, MA AA000188, RI AAL-10773 and VT AL357102

Initial report from 02/19/2013 15:04:23



EMSL Analytical, Inc.

7 Constitution Way, Suite 107, Woburn, MA 01801

Phone/Fax: (781) 933-8411 / (781) 933-8412

bostonlab@emsl.com

EMSL Order: 131300630

CustomerID: ENVI54

CustomerPO:

ProjectID:

Attn: **Dustin Diedricksen**
Fuss & O'Neill EnviroScience, LLC
146 Hartford Road
Manchester, CT 06040

Phone: (860) 646-2469
Fax: (888) 838-1160
Received: 02/18/13 11:55 AM
Analysis Date: 2/19/2013
Collected: 2/15/2013

Project: **20121733.A1E / Cambridge City Hall; LDA Architects & Interiors; City Hall; 795 Massachusetts Ave; Cambridge, MA**

Test Report: Asbestos Analysis of Bulk Materials via EPA 600/R-93/116 and/or EPA 600/M4-82-020 Method(s) using Polarized Light Microscopy

Sample	Description	Appearance	Non-Asbestos		Asbestos
			% Fibrous	% Non-Fibrous	% Type
0215LM-26A 131300630-0064	Senior Center Ballroom - Grey Ceiling Tile	Gray/White Fibrous Homogeneous	35% Cellulose 35% Min. Wool	30% Non-fibrous (other)	None Detected
0215LM-26B 131300630-0065	Senior Center Ballroom - Grey Ceiling Tile	Gray/White Fibrous Homogeneous	35% Cellulose 35% Min. Wool	30% Non-fibrous (other)	None Detected
0215LM-26C 131300630-0066	Senior Center Ballroom - Grey Ceiling Tile	Gray Fibrous Heterogeneous	40% Cellulose 35% Glass	25% Non-fibrous (other)	None Detected
0215LM-27A 131300630-0067	Senior Center Ballroom - 4" Vinyl Baseboard	Brown Non-Fibrous Homogeneous		100% Non-fibrous (other)	None Detected
0215LM-27B 131300630-0068	Senior Center Ballroom - 4" Vinyl Baseboard	Brown Non-Fibrous Homogeneous		100% Non-fibrous (other)	None Detected
0215LM-27C 131300630-0069	Senior Center Ballroom - 4" Vinyl Baseboard	Red Non-Fibrous Homogeneous		100% Non-fibrous (other)	None Detected
0215LM-28A 131300630-0070	Senior Center Ballroom - Joint Compound	White Non-Fibrous Homogeneous		100% Non-fibrous (other)	None Detected
0215LM-28B 131300630-0071	Senior Center Ballroom - Joint Compound	White Non-Fibrous Homogeneous		100% Non-fibrous (other)	None Detected

Analyst(s)

Renaldo Drakes (31)

Steve Grise (49)

Renaldo Drakes, Laboratory Manager
or other approved signatory

EMSL maintains liability limited to cost of analysis. This report relates only to the samples reported and may not be reproduced, except in full, without written approval by EMSL. EMSL bears no responsibility for sample collection activities or analytical method limitations. Interpretation and use of test results are the responsibility of the client. This report must not be used by the client to claim product certification, approval, or endorsement by NVLAP, NIST or any agency of the federal government. Non-friable organically bound materials present a problem matrix and therefore EMSL recommends gravimetric reduction prior to analysis. Samples received in good condition unless otherwise noted. Estimated accuracy, precision and uncertainty data available upon request. Unless requested by the client, building materials manufactured with multiple layers (i.e. linoleum, wallboard, etc.) are reported as a single sample. Reporting limit is 1%
Samples analyzed by EMSL Analytical, Inc. Woburn, MA NVLAP Lab Code 101147-0, CT PH-0315, MA AA000188, RI AAL-10773 and VT AL357102

Initial report from 02/19/2013 15:04:23



EMSL Analytical, Inc.

7 Constitution Way, Suite 107, Woburn, MA 01801

Phone/Fax: (781) 933-8411 / (781) 933-8412

bostonlab@emsl.com

EMSL Order: 131300630

CustomerID: ENVI54

CustomerPO:

ProjectID:

Attn: **Dustin Diedricksen**
Fuss & O'Neill EnviroScience, LLC
146 Hartford Road
Manchester, CT 06040

Phone: (860) 646-2469
Fax: (888) 838-1160
Received: 02/18/13 11:55 AM
Analysis Date: 2/19/2013
Collected: 2/15/2013

Project: **20121733.A1E / Cambridge City Hall; LDA Architects & Interiors; City Hall; 795 Massachusetts Ave; Cambridge, MA**

Test Report: Asbestos Analysis of Bulk Materials via EPA 600/R-93/116 and/or EPA 600/M4-82-020 Method(s) using Polarized Light Microscopy

Sample	Description	Appearance	Non-Asbestos		Asbestos
			% Fibrous	% Non-Fibrous	% Type
0215LM-28C 131300630-0072	Senior Center Ballroom - Joint Compound	White Non-Fibrous Heterogeneous		100% Non-fibrous (other)	None Detected
0215LM-29A 131300630-0073	Senior Center Ballroom - Mastic (Yellow) a/w 12x12 Floor Tile	Yellow Non-Fibrous Homogeneous		100% Non-fibrous (other)	None Detected
0215LM-29B 131300630-0074	Senior Center Ballroom - Mastic (Yellow) a/w 12x12 Floor Tile	Yellow Non-Fibrous Homogeneous		100% Non-fibrous (other)	None Detected
0215LM-29C 131300630-0075	Senior Center Ballroom - Mastic (Yellow) a/w 12x12 Floor Tile	Brown Non-Fibrous Homogeneous		100% Non-fibrous (other)	None Detected
0215LM-30A 131300630-0076	Senior Center Ballroom - Drywall	Gray Fibrous Homogeneous	5% Cellulose	95% Non-fibrous (other)	None Detected
0215LM-30B 131300630-0077	Senior Center Ballroom - Drywall	Gray Fibrous Homogeneous	5% Cellulose	95% Non-fibrous (other)	None Detected
0215LM-30C 131300630-0078	Senior Center Ballroom - Drywall	White Non-Fibrous Heterogeneous		100% Non-fibrous (other)	None Detected

Analyst(s)

Renaldo Drakes (31)

Steve Grise (49)

Renaldo Drakes, Laboratory Manager
or other approved signatory

EMSL maintains liability limited to cost of analysis. This report relates only to the samples reported and may not be reproduced, except in full, without written approval by EMSL. EMSL bears no responsibility for sample collection activities or analytical method limitations. Interpretation and use of test results are the responsibility of the client. This report must not be used by the client to claim product certification, approval, or endorsement by NVLAP, NIST or any agency of the federal government. Non-friable organically bound materials present a problem matrix and therefore EMSL recommends gravimetric reduction prior to analysis. Samples received in good condition unless otherwise noted. Estimated accuracy, precision and uncertainty data available upon request. Unless requested by the client, building materials manufactured with multiple layers (i.e. linoleum, wallboard, etc.) are reported as a single sample. Reporting limit is 1%
Samples analyzed by EMSL Analytical, Inc. Woburn, MA NVLAP Lab Code 101147-0, CT PH-0315, MA AA000188, RI AAL-10773 and VT AL357102

Initial report from 02/19/2013 15:04:23



EMSL Analytical, Inc.

7 Constitution Way, Suite 107, Woburn, MA 01801

Phone/Fax: (781) 933-8411 / (781) 933-8412

bostonlab@emsl.com

EMSL Order: 131300630

CustomerID: ENVI54

CustomerPO:

ProjectID:

Attn: **Dustin Diedricksen**
Fuss & O'Neill EnviroScience, LLC
146 Hartford Road
Manchester, CT 06040

Phone: (860) 646-2469
Fax: (888) 838-1160
Received: 02/18/13 11:55 AM
Analysis Date: 2/19/2013
Collected: 2/15/2013

Project: 20121733.A1E / Cambridge City Hall; LDA Architects & Interiors; City Hall; 795 Massachusetts Ave; Cambridge, MA

Test Report: Asbestos Analysis of Bulk Materials via EPA 600/R-93/116 and/or EPA 600/M4-82-020 Method(s) using Polarized Light Microscopy

Sample	Description	Appearance	Non-Asbestos		Asbestos
			% Fibrous	% Non-Fibrous	% Type
0215LM-121A 131300630-0079	Lombardi Room - White Mastic a/w 4" Blue Vinyl Baseboard	White Non-Fibrous Homogeneous		100% Non-fibrous (other)	None Detected
0215LM-121B 131300630-0080	Lombardi Room - White Mastic a/w 4" Blue Vinyl Baseboard	Yellow Non-Fibrous Homogeneous		100% Non-fibrous (other)	None Detected

Analyst(s)

Renaldo Drakes (31)

Steve Grise (49)

Renaldo Drakes, Laboratory Manager
or other approved signatory

EMSL maintains liability limited to cost of analysis. This report relates only to the samples reported and may not be reproduced, except in full, without written approval by EMSL. EMSL bears no responsibility for sample collection activities or analytical method limitations. Interpretation and use of test results are the responsibility of the client. This report must not be used by the client to claim product certification, approval, or endorsement by NVLAP, NIST or any agency of the federal government. Non-friable organically bound materials present a problem matrix and therefore EMSL recommends gravimetric reduction prior to analysis. Samples received in good condition unless otherwise noted. Estimated accuracy, precision and uncertainty data available upon request. Unless requested by the client, building materials manufactured with multiple layers (i.e. linoleum, wallboard, etc.) are reported as a single sample. Reporting limit is 1%
Samples analyzed by EMSL Analytical, Inc. Woburn, MA NVLAP Lab Code 101147-0, CT PH-0315, MA AA000188, RI AAL-107T3 and VT AL357102

Initial report from 02/19/2013 15:04:23



EMSL Analytical, Inc.

7 Constitution Way, Suite 107, Woburn, MA 01801

Phone/Fax: (781) 933-8411 / (781) 933-8412

bostonlab@emsl.com

EMSL Order: 131300630

CustomerID: ENVI54

CustomerPO:

ProjectID:

Attn: **Dustin Diedricksen**
Fuss & O'Neill EnviroScience, LLC
146 Hartford Road
Manchester, CT 06040

Phone: (860) 646-2469
Fax: (888) 838-1160
Received: 02/18/13 11:55 AM
Analysis Date: 2/19/2013
Collected: 2/15/2013

Project: **20121733.A1E / Cambridge City Hall; LDA Architects & Interiors; City Hall; 795 Massachusetts Ave; Cambridge, MA**

Test Report: Asbestos Analysis of Bulk Materials via EPA 600/R-93/116 and/or EPA 600/M4-82-020 Method(s) using Polarized Light Microscopy

Sample	Description	Appearance	Non-Asbestos		Asbestos
			% Fibrous	% Non-Fibrous	% Type
0215LM-26A 131300630-0064	Senior Center Ballroom - Grey Ceiling Tile	Gray/White Fibrous Homogeneous	35% Cellulose 35% Min. Wool	30% Non-fibrous (other)	None Detected
0215LM-26B 131300630-0065	Senior Center Ballroom - Grey Ceiling Tile	Gray/White Fibrous Homogeneous	35% Cellulose 35% Min. Wool	30% Non-fibrous (other)	None Detected
0215LM-26C 131300630-0066	Senior Center Ballroom - Grey Ceiling Tile	Gray Fibrous Heterogeneous	40% Cellulose 35% Glass	25% Non-fibrous (other)	None Detected
0215LM-27A 131300630-0067	Senior Center Ballroom - 4" Vinyl Baseboard	Brown Non-Fibrous Homogeneous		100% Non-fibrous (other)	None Detected
0215LM-27B 131300630-0068	Senior Center Ballroom - 4" Vinyl Baseboard	Brown Non-Fibrous Homogeneous		100% Non-fibrous (other)	None Detected
0215LM-27C 131300630-0069	Senior Center Ballroom - 4" Vinyl Baseboard	Red Non-Fibrous Homogeneous		100% Non-fibrous (other)	None Detected
0215LM-28A 131300630-0070	Senior Center Ballroom - Joint Compound	White Non-Fibrous Homogeneous		100% Non-fibrous (other)	None Detected
0215LM-28B 131300630-0071	Senior Center Ballroom - Joint Compound	White Non-Fibrous Homogeneous		100% Non-fibrous (other)	None Detected

Analyst(s)

Renaldo Drakes (31)

Steve Grise (49)

Renaldo Drakes, Laboratory Manager
or other approved signatory

EMSL maintains liability limited to cost of analysis. This report relates only to the samples reported and may not be reproduced, except in full, without written approval by EMSL. EMSL bears no responsibility for sample collection activities or analytical method limitations. Interpretation and use of test results are the responsibility of the client. This report must not be used by the client to claim product certification, approval, or endorsement by NVLAP, NIST or any agency of the federal government. Non-friable organically bound materials present a problem matrix and therefore EMSL recommends gravimetric reduction prior to analysis. Samples received in good condition unless otherwise noted. Estimated accuracy, precision and uncertainty data available upon request. Unless requested by the client, building materials manufactured with multiple layers (i.e. linoleum, wallboard, etc.) are reported as a single sample. Reporting limit is 1%
Samples analyzed by EMSL Analytical, Inc. Woburn, MA NVLAP Lab Code 101147-0, CT PH-0315, MA AA000188, RI AAL-10773 and VT AL357102

Initial report from 02/19/2013 15:04:23



EMSL Analytical, Inc.

7 Constitution Way, Suite 107, Woburn, MA 01801

Phone/Fax: (781) 933-8411 / (781) 933-8412

bostonlab@emsl.com

EMSL Order: 131300630

CustomerID: ENVI54

CustomerPO:

ProjectID:

Attn: **Dustin Diedricksen**
Fuss & O'Neill EnviroScience, LLC
146 Hartford Road
Manchester, CT 06040

Phone: (860) 646-2469
Fax: (888) 838-1160
Received: 02/18/13 11:55 AM
Analysis Date: 2/19/2013
Collected: 2/15/2013

Project: **20121733.A1E / Cambridge City Hall; LDA Architects & Interiors; City Hall; 795 Massachusetts Ave; Cambridge, MA**

Test Report: Asbestos Analysis of Bulk Materials via EPA 600/R-93/116 and/or EPA 600/M4-82-020 Method(s) using Polarized Light Microscopy

Sample	Description	Appearance	Non-Asbestos		Asbestos
			% Fibrous	% Non-Fibrous	% Type
0215LM-28C 131300630-0072	Senior Center Ballroom - Joint Compound	White Non-Fibrous Heterogeneous		100% Non-fibrous (other)	None Detected
0215LM-29A 131300630-0073	Senior Center Ballroom - Mastic (Yellow) a/w 12x12 Floor Tile	Yellow Non-Fibrous Homogeneous		100% Non-fibrous (other)	None Detected
0215LM-29B 131300630-0074	Senior Center Ballroom - Mastic (Yellow) a/w 12x12 Floor Tile	Yellow Non-Fibrous Homogeneous		100% Non-fibrous (other)	None Detected
0215LM-29C 131300630-0075	Senior Center Ballroom - Mastic (Yellow) a/w 12x12 Floor Tile	Brown Non-Fibrous Homogeneous		100% Non-fibrous (other)	None Detected
0215LM-30A 131300630-0076	Senior Center Ballroom - Drywall	Gray Fibrous Homogeneous	5% Cellulose	95% Non-fibrous (other)	None Detected
0215LM-30B 131300630-0077	Senior Center Ballroom - Drywall	Gray Fibrous Homogeneous	5% Cellulose	95% Non-fibrous (other)	None Detected
0215LM-30C 131300630-0078	Senior Center Ballroom - Drywall	White Non-Fibrous Heterogeneous		100% Non-fibrous (other)	None Detected

Analyst(s)

Renaldo Drakes (31)

Steve Grise (49)

Renaldo Drakes, Laboratory Manager
or other approved signatory

EMSL maintains liability limited to cost of analysis. This report relates only to the samples reported and may not be reproduced, except in full, without written approval by EMSL. EMSL bears no responsibility for sample collection activities or analytical method limitations. Interpretation and use of test results are the responsibility of the client. This report must not be used by the client to claim product certification, approval, or endorsement by NVLAP, NIST or any agency of the federal government. Non-friable organically bound materials present a problem matrix and therefore EMSL recommends gravimetric reduction prior to analysis. Samples received in good condition unless otherwise noted. Estimated accuracy, precision and uncertainty data available upon request. Unless requested by the client, building materials manufactured with multiple layers (i.e. linoleum, wallboard, etc.) are reported as a single sample. Reporting limit is 1%
Samples analyzed by EMSL Analytical, Inc. Woburn, MA NVLAP Lab Code 101147-0, CT PH-0315, MA AA000188, RI AAL-10773 and VT AL357102

Initial report from 02/19/2013 15:04:23



EMSL Analytical, Inc.

7 Constitution Way, Suite 107, Woburn, MA 01801

Phone/Fax: (781) 933-8411 / (781) 933-8412

bostonlab@emsl.com

EMSL Order: 131300630

CustomerID: ENVI54

CustomerPO:

ProjectID:

Attn: **Dustin Diedricksen**
Fuss & O'Neill EnviroScience, LLC
146 Hartford Road
Manchester, CT 06040

Phone: (860) 646-2469
Fax: (888) 838-1160
Received: 02/18/13 11:55 AM
Analysis Date: 2/19/2013
Collected: 2/15/2013

Project: **20121733.A1E / Cambridge City Hall; LDA Architects & Interiors; City Hall; 795 Massachusetts Ave; Cambridge, MA**

Test Report: Asbestos Analysis of Bulk Materials via EPA 600/R-93/116 and/or EPA 600/M4-82-020 Method(s) using Polarized Light Microscopy

Sample	Description	Appearance	Non-Asbestos		Asbestos
			% Fibrous	% Non-Fibrous	% Type
0215LM-121A 131300630-0079	Lombardi Room - White Mastic a/w 4" Blue Vinyl Baseboard	White Non-Fibrous Homogeneous		100% Non-fibrous (other)	None Detected
0215LM-121B 131300630-0080	Lombardi Room - White Mastic a/w 4" Blue Vinyl Baseboard	Yellow Non-Fibrous Homogeneous		100% Non-fibrous (other)	None Detected

Analyst(s)

Renaldo Drakes (31)

Steve Grise (49)

Renaldo Drakes, Laboratory Manager
or other approved signatory

EMSL maintains liability limited to cost of analysis. This report relates only to the samples reported and may not be reproduced, except in full, without written approval by EMSL. EMSL bears no responsibility for sample collection activities or analytical method limitations. Interpretation and use of test results are the responsibility of the client. This report must not be used by the client to claim product certification, approval, or endorsement by NVLAP, NIST or any agency of the federal government. Non-friable organically bound materials present a problem matrix and therefore EMSL recommends gravimetric reduction prior to analysis. Samples received in good condition unless otherwise noted. Estimated accuracy, precision and uncertainty data available upon request. Unless requested by the client, building materials manufactured with multiple layers (i.e. linoleum, wallboard, etc.) are reported as a single sample. Reporting limit is 1%
Samples analyzed by EMSL Analytical, Inc. Woburn, MA NVLAP Lab Code 101147-0, CT PH-0315, MA AA000188, RI AAL-107T3 and VT AL357102

Initial report from 02/19/2013 15:04:23



FUSS & O'NEILL
EnviroScience, LLC

131300630

www.fando.com

50 Redfield St, Suite 100, Boston, MA 02122

(617) 282-4675 Fax (617) 282-8253

SAMPLE LOG FOR ASBESTOS BULKS

Sheet 1 of 8

Project Name: CAMBRIDGE CITY HALL - LDC ARCHITECTS + INTERIORS Project No. 20121733.A1E

Building: CITY HALL - 795 MASSACHUSETTS AVE CAMBRIDGE MA Project Manager: DUSTIN DIEDRIKSEN

Sample ID	Sample Location	Material	Result (%)
1 Q15LM-01A	SULLIVAN CHAMBER	DECORATIVE PLASTER	
2 ↓ -01B	↓	↓	
3 ↓ -01C	↓	↓	
4 Q215LM-02A	SULLIVAN CHAMBER	CURVED CEILING SKIM	
5 ↓ -02B	↓	↓	
6 ↓ -02C	↓	↓	
7 ↓ -03A	SULLIVAN CHAMBER	CURVED CEILING ROUGHCAST	
8 ↓ -03B	↓	↓	
9 ↓ -03C	↓	↓	
10 ↓ -04A	SULLIVAN CHAMBER	WALL SKIM PLASTER	
11 ↓ -04B	↓	↓	
12 Q215LM-05A	SULLIVAN CHAMBER	WALL PLASTER ROUGHCAST	

Analysis Method: PLM Other

Turnaround Time 24 HOUR FOR PLM

Based on the turnaround time indicated above, analyses are due to EnviroScience on or before this date: 2/18 48 HOUR FOR TEM
Laboratory if analyses will be late at (860) 646-2469. Please call the EnviroScience

Fax Results to the EnviroScience Laboratory at: 860-812-2228.

Special Instruction: STOP AT 1ST POSITIVE COUNT IN EACH HOMOGENEOUS SET. NO POINT COUNTING.

ADDITIONAL NOTE ON PAGE 5. RUN TEM ON -15A, -18A, -21A-23A, -27A, -29A AND -121A IF ALL PLM ARE NEGATIVE FIRST.

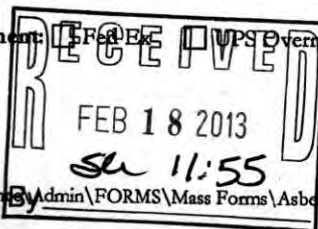
Samples collected by: JH + LM Date: 2/15/13 Time: PM

Samples [Rec'd][Sent by] [LM] Date: [2/18/13] Time: PM

Samples Received by: _____ Date: _____ Time: _____

Shipped To: EMSL State MA Other _____

Method of Shipment: FedEx UPS Overnight UPS Ground Other DMP OFF



TEM NOT TO EXCEED 7 SAMPLES - 48 HOUR ON TEM.



FUSS & O'NEILL
EnviroScience, LLC

131300630

www.fando.com

50 Redfield St, Suite 100, Boston, MA 02122

(617) 282-4675 Fax (617) 282-8253

SAMPLE LOG FOR ASBESTOS BULKLS

Sheet 2 of 8

Project Name: CAMBRIDGE CITY HALL - LDA ARCHITECTS INTERIORS Project No. 2012 1733 AIE

Building: CITY HALL 495 MASSACHUSETTS AVE CAMBRIDGE MA Project Manager: JUSTIN DIEDRICKSEN

Sample ID	Sample Location	Material	Result (%)
13 021514-05B	SULLIVAN HALL	WALL PLASTER RAISED COAT	
14 ↓ -06A	SULLIVAN HALL	CEILING TILE	
15 ↓ -06B	↓	↓	
16 ↓ -06C	↓	↓	
17 021514-07A	SOPHIE ANASTOS REOP	PIPE-THREAD SEALANT	
18 ↓ -07B	↓	↓	
X 021514-07C	↓	↓	
19 021514-08A	SOPHIE ANASTOS	TEXTURED CEILING TILE	
20 ↓ -08B	↓	↓	
X 021514-08C	↓	↓	
21 021514-09A	SOPHIE ANASTOS	CEILING RAISED COAT	
22 ↓ -09B	↓	↓	

Analysis Method: PLM Other

Turnaround Time 24 Hour

Based on the turnaround time indicated above, analyses are due to EnviroScience on or before this date: 2/18. Please call the EnviroScience Laboratory if analyses will be late at (860) 646-2469.

Fax Results to the EnviroScience Laboratory at: 860-812-2228.

Special Instruction: SEE 1ST PAGE.

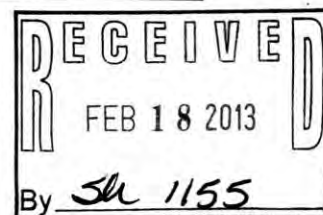
Samples collected by: JH + LM Date: 2/15/13 Time: PM

Samples [Rec'd][Sent by] [LM] Date: [2/18/13] Time: PM

Samples Received by: _____ Date: _____ Time: _____

Shipped To: EMSL State MA Other DROP OFF

Method of Shipment: Fed Ex UPS Overnight UPS Ground Other





FUSS & O'NEILL
EnviroScience, LLC

131300630

www.fando.com

50 Redfield St, Suite 100, Boston, MA 02122

(617) 282-4675 Fax (617) 282-8253

SAMPLE LOG FOR ASBESTOS BULKS

Sheet 3 of 8

Project Name: CAMBRIDGE CITY HALL - 2DA ARCHITECTS + INTERIORS Project No. 20121733 AIE
 Building: CAMBRIDGE CITY HALL - CAMBRIDGE MA Project Manager: DUSTIN A DIEBRICKSEN

Sample ID	Sample Location	Material	Result (%)
23 0215LM-09C	SOPHIE ANASTAS	CEILING ROUGH COAT	
24 0215LM-10A	SOPHIE ANASTAS	WINDOW CAULKING	
25 ↓ -10B	↓	↓	
X	~~~~~		
26 0215LM-11A	SOPHIE ANASTAS	CEILING SKIM	
27 ↓ -11B	↓	↓	
28 ↓ -11C	↓	↓	
29 0215LM-12A	SOPHIE ANASTAS	DRY WALL	
30 ↓ -12B	↓	↓	
31 ↓ -12C	↓	↓	
32 0215LM-13A	SOPHIE ANASTAS	WINDOW GLAZING Compound	
33 ↓ -13B	↓	↓	

Analysis Method: PLM Other

Turnaround Time 24 HR PLM

Based on the turnaround time indicated above, analyses are due to EnviroScience on or before this date: 2/18. Please call the EnviroScience Laboratory if analyses will be late at (860) 646-2469.

Fax Results to the EnviroScience Laboratory at: 860-812-2228.

Special Instruction: SEE PAGE 1

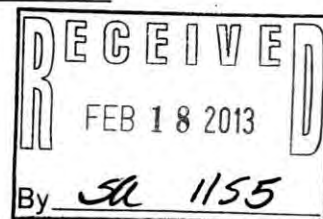
Samples collected by: LMJ/JH Date: 2/15/13 Time: PM

Samples [Rec'd][Sent by] [LMJ] Date: [2/18/13] Time: PM

Samples Received by: _____ Date: _____ Time: _____

Shipped To: EMSL State MA Other DROP OFF

Method of Shipment: Fed Ex UPS Overnight UPS Ground Other





FUSS & O'NEILL
EnviroScience, LLC

131300630

www.fando.com

50 Redfield St, Suite 100, Boston, MA 02122

(617) 282-4675 Fax (617) 282-8253

SAMPLE LOG FOR ASBESTOS BULKS

Sheet 4 of 8

Project Name: Cambridge City Hall - Loe Architecture + Interiors Project No. 2012733.AIE

Building: Cambridge City Hall Project Manager: DUSTIN A. DIETRICHSEN

Sample ID	Sample Location	Material	Result (%)
X 0215LM-13A	SOPHIE ANASTAS	WINDOW GLAZING COMPOUND	
34 0215LM-14A	SOPHIE ANASTAS	JOINT COMPOUND	
35 ↓ -14B	↓	↓	
36 ↓ -14C	↓	↓	
37 (A) 0215LM-15A	SOPHIE ANASTAS	CARPET GLUE + LEVELING	
38 -15B	↓	COMPOUND	
X 0215LM-16A	ACKERMANN	INTERIOR WINDOW GLAZING COMPOUND	
39 0215LM-16A	ACKERMANN	INTERIOR WINDOW GLAZING COMPOUND	
40 -16B	↓	↓	
41 0215LM-17A	ACKERMANN	WIRE COATING	
42 -17B	↓	↓	
43 (B) 0215LM-18A	LOMBARDI	BLACK + YELLOW CARPET GLUE	

Analysis Method: PLM Other

Turnaround Time 24 HR

Based on the turnaround time indicated above, analyses are due to EnviroScience on or before this date: 2/18. Please call the EnviroScience Laboratory if analyses will be late at (860) 646-2469.

Fax Results to the EnviroScience Laboratory at: 860-812-2228.

Special Instruction: SEE 1ST PAGE

(A) RUN CONFIRMATORY TEM SAMPLE IF ALL PLM ARE

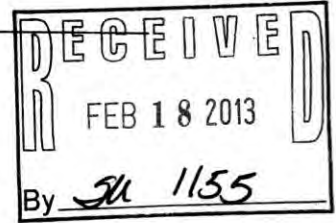
Samples collected by: LYY + JH Date: 2/15/13 Time: PM NEGATIVE.

Samples [Rec'd] [Sent by] [LYY] Date: [2/18/13] Time: PM

Samples Received by: _____ Date: _____ Time: _____

Shipped To: EMSL State MA Other DROP OFF

Method of Shipment: Fed Ex UPS Overnight UPS Ground Other





FUSS & O'NEILL
EnviroScience, LLC

131300630

www.fando.com

50 Redfield St, Suite 100, Boston, MA 02122

(617) 282-4675 Fax (617) 282-8253

SAMPLE LOG FOR ASBESTOS BULKLS

Sheet 5 of 8

Project Name: CAMBRIDGE CITY HALL - LPA Architecture + Interiors Project No. 20121733.AIE

Building: CITY HALL - CAMBRIDGE MA Project Manager: DUSTINA DEDRICKSEN

Sample ID	Sample Location	Material	Result (%)
44 Q215LM-18B	Lombardi	BLACK+YELLOW CARPET GLUE	
45 Q215LM-18C	Lombardi	BLACK+YELLOW CARPET GLUE	
45 Q215LM-19A	Lombardi	JOINT COMPOUND	
46 ↓ -19B	↓	↓	
47 ↓ -19C	↓	↓	
48 Q215LM-20A	Lombardi	DRYWALL	
49 ↓ -20B	↓	↓	
50 ↓ -20C	↓	↓	
51 Q215LM-21A	Lombardi	4" BLUE VINYL BASEBOARD	
52 ↓ -21B	↓	↓	
53 Q215LM-22A	Lombardi	CEILING TILE	

51
52
MASTIC
IS
-121 A+B
ON LAST
PAGE

Analysis Method: PLM Other Turnaround Time 24 HR
Based on the turnaround time indicated above, analyses are due to EnviroScience on or before this date: 2/18. Please call the EnviroScience Laboratory if analyses will be late at (860) 646-2469. 48 HR FOR TEM

Fax Results to the EnviroScience Laboratory at: 860-812-2228.

Special Instruction: NOTE MASTIC FOR 4" BLUE VINYL BASEBOARD IS # -121 A+B ON LAST PAGE.
also SEE 1st PAGE

Samples collected by: LM + JH Date: 2/15/13 Time: PM

Samples [Rec'd][Sent by] [LM] Date: [2/18/13] Time: PM

Samples Received by: _____ Date: _____ Time: _____

Shipped To: EMSL State MA Other DROP OFF

Method of Shipment: Fed Ex UPS Overnight UPS Ground Other

RECEIVED
FEB 18 2013
By SU 1155



FUSS & O'NEILL
EnviroScience, LLC

50 Redfield St, Suite 100, Boston, MA 02122

131300630

www.fando.com

(617) 282-4675 Fax (617) 282-8253

SAMPLE LOG FOR ASBESTOS BULKS

Sheet 6 of 8

Project Name: Cambridge City Hall - LDs Architecture Interiors Project No. 2012733.AIE

Building: Cambridge City Hall Project Manager: DUSTIN A DIEPRICK SEN

Sample ID	Sample Location	Material	Result (%)
54 X 0215LM-220	Lombardi	Ceiling Tile	
0215LM-221	_____	_____	
55 0215LM-23A	Senior Center Ballroom	12x12 Floor Tile	
56 ↓ -23B	↓	↓	
57 ↓ -23C	↓	↓	
58 0215LM-24A	Senior Center Ballroom	1x1 Ceiling Tile (White)	
59 ↓ -24B	↓	↓	
60 ↓ -24C	↓	↓	
61 0215LM-25A	Senior Center Ballroom	Fisher Dot 2x2	
62 ↓ -25B	↓	Ceiling Tile	
63 ↓ -25C	↓	↓	
64 0215LM-26A	Senior Center Ballroom	Grey Ceiling Tile	

Analysis Method: PLM Other

Turnaround Time 24 HR

Based on the turnaround time indicated above, analyses are due to EnviroScience on or before this date: 2/18 48 HR for TET
Laboratory if analyses will be late at (860) 646-2469. Please call the EnviroScience

Fax Results to the EnviroScience Laboratory at: 860-812-2228.

Special Instruction: SEE 1ST PAGE

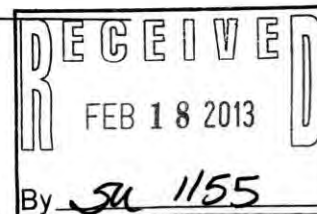
Samples collected by: LM + JH Date: 2/15/13 Time: PM

Samples [Rec'd][Sent by] [LM] Date: [2/18/13] Time: PM

Samples Received by: _____ Date: _____ Time: _____

Shipped To: EMSL State _____ Other DROP OFF

Method of Shipment: Fed Ex UPS Overnight UPS Ground Other





FUSS & O'NEILL
EnviroScience, LLC

131300630

www.fando.com

50 Redfield St, Suite 100, Boston, MA 02122

(617) 282-4675 Fax (617) 282-8253

SAMPLE LOG FOR ASBESTOS BULKS

Sheet 7 of 8

Project Name: CAMBRIDGE City Hall - LDA Architecture + Interiors Project No. 20121733 AIE

Building: City Hall - 795 Massachusetts Ave Cambridge MA Project Manager: Dustin A Dedrickson

Sample ID	Sample Location	Material	Result (%)
65 0215LM-26B	Senior Center Ballroom	Grey Ceiling Tile	
66 ↓ -26C	↓	↓	
67 0215LM-27A	Senior Center Ballroom	4" Vinyl Baseboard	
68 ↓ -27B	↓	↓	
69 ↓ -27C	↓	↓	
70 0215LM-28A	Senior Center Ballroom	Sealant Compound	
71 ↓ -28B	↓	↓	
72 ↓ -28C	↓	↓	
73 0215LM-29A	Senior Center Ballroom	Mosaic (Yellow) A/W 12x12	
74 ↓ -29B	↓	FLOOR TILE	
75 ↓ -29C	↓	↓	
76 0215LM-30A	Senior Center Ballroom	Daywall	

Analysis Method: PLM Other

Turnaround Time 24 HR

Based on the turnaround time indicated above, analyses are due to EnviroScience on or before this date: 2/18. Please call the EnviroScience Laboratory if analyses will be late at (860) 646-2469. 48 HR for TEM

Fax Results to the EnviroScience Laboratory at: 860-812-2228.

Special Instruction: SEE 1ST PAGE

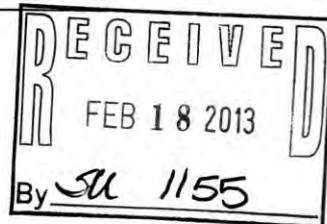
Samples collected by: LM + JH Date: 2/15/13 Time: PM

Samples [Rec'd][Sent by] [LM] Date: [2/18/13] Time: PM

Samples Received by: _____ Date: _____ Time: _____

Shipped To: EMSL State MA Other DROP OFF

Method of Shipment: Fed Ex UPS Overnight UPS Ground Other





FUSS & O'NEILL
EnviroScience, LLC

131300630

www.fando.com

50 Redfield St, Suite 100, Boston, MA 02122

(617) 282-4675 Fax (617) 282-8253

SAMPLE LOG FOR ASBESTOS BULKS

Sheet 8 of 8

Project Name: CAMBRIDGE City Hall - 2 Da Architecture + Interiors Project No. 20121733.AIE

Building: CAMBRIDGE City Hall Project Manager: DUSTIN DERRICKSEN

Sample ID	Sample Location	Material	Result (%)
77 78 79 80 0215LM-30B	Senior Center Ballroom	DRYWALL	
↓ 30C	↓	↓	
0215LM-121A	LOMBARDI ROOM	WHITE MASTIC ASSOCIATED	
-121B	↓	WITH 4" BLUE VINYL BOARD	

Analysis Method: PLM Other

Turnaround Time 24 hr
48 hr for TEM
Based on the turnaround time indicated above, analyses are due to EnviroScience on or before this date: 2/18. Please call the EnviroScience Laboratory if analyses will be late at (860) 646-2469.

Fax Results to the EnviroScience Laboratory at: 860-812-2228.

Special Instruction: SEE 1ST PAGE

Samples collected by: LM+JH Date: 2/15/13 Time: PM

Samples [Rec'd][Sent by] [LM] Date: [2/18/13] Time: PM

Samples Received by: _____ Date: _____ Time: _____

Shipped To: EMSL State MA Other DROP OFF

Method of Shipment: Fed Ex UPS Overnight UPS Ground Other

RECEIVED
FEB 18 2013
By JM 1155

Appendix C

TEM Laboratory Analysis Results

**EMSL Analytical, Inc.**

7 Constitution Way, Suite 107, Woburn, MA 01801

Phone/Fax: (781) 933-8411 / (781) 933-8412

bostonlab@emsl.com

EMSL Order:	131300630
CustomerID:	ENVI54
CustomerPO:	
ProjectID:	

Attn: **Dustin Diedricksen**
Fuss & O'Neill EnviroScience, LLC
146 Hartford Road
Manchester, CT 06040

Phone: (860) 646-2469
 Fax: (888) 838-1160
 Received: 02/18/13 11:55 AM
 Analysis Date: 2/20/2013
 Collected: 2/15/2013

Project: 20121733.A1E / Cambridge City Hall; LDA Architects & Interiors; City Hall; 795 Massachusetts Ave; Cambridge, MA

Test Report: Asbestos Analysis of Non-Friable Organically Bound Materials by TEM via EPA/600/R-93/116 Section 2.5.5.1

SAMPLE ID	DESCRIPTION	APPEARANCE	% MATRIX MATERIAL	% NON-ASBESTOS FIBERS	ASBESTOS TYPES
0215LM-15A 131300630-0037	Sophie Anastos - Carpet Glue - Leveling Compound	Gray /Yellow Non-Fibrous Heterogeneous	100	None	No Asbestos Detected
0215LM-18A 131300630-0043	Lombardi - Black & Yellow Carpet Glue	Black /Yellow Non-Fibrous Heterogeneous	100	None	<0.33% Chrysotile
0215LM-21A 131300630-0051	Lombardi - 4" Blue Vinyl Baseboard	Blue Non-Fibrous Homogeneous	100	None	No Asbestos Detected
0215LM-23A 131300630-0055	Senior Center Ballroom - 12x12 Floor Tile	Beige Non-Fibrous Homogeneous	100	None	No Asbestos Detected
0215LM-27A 131300630-0067	Senior Center Ballroom - 4" Vinyl Baseboard	Brown Non-Fibrous Homogeneous	100	None	No Asbestos Detected
0215LM-29A 131300630-0073	Senior Center Ballroom - Mastic (Yellow) a/w 12x12 Floor Tile	Yellow Non-Fibrous Homogeneous	100	None	No Asbestos Detected
0215LM-121A 131300630-0079	Lombardi Room - White Mastic a/w 4" Blue Vinyl Baseboard	White Non-Fibrous Homogeneous	100	None	No Asbestos Detected

Analyst(s) _____
 Allison Libeskind (7)

Renaldo Drakes, Laboratory Manager
 or other approved signatory

This laboratory is not responsible for % asbestos in total sample when the residue only is submitted for analysis. The above report relates only to the items tested. This report may not be reproduced, except in full, without written approval by EMSL Analytical, Inc. Samples received in good condition unless otherwise noted. Unless requested by the client, building materials manufactured with multiple layers (i.e. linoleum, wallboard, etc.) are reported as a single sample.
 Samples analyzed by EMSL Analytical, Inc. Woburn, MA

Initial report from 02/20/2013 17:41:56

Appendix D

Lead Paint Testing Procedures and Equipment

STANDARD OPERATING PROCEDURES TESTING PROCEDURES AND EQUIPMENT

(Commonwealth of Massachusetts)

Massachusetts General Laws (M.G.L.) c. III, §190-199A 105CMR 460 with reference to lead based paint testing were consulted for this inspection. This regulation is administered by the Massachusetts Department of Public Health's Lead Poisoning Prevention Program. EnviroScience inspectors are licensed by the Commonwealth under this regulation.

This lead evaluation was either comprehensive or a determination. Both the proposed scope of work and the final report will note which type of evaluation was done. A comprehensive inspection means that representative painted surfaces were systematically evaluated on a room by room basis in accordance with the above referenced Massachusetts regulations.

A lead determination means that only a few surfaces were tested and that conclusions about untested areas cannot be reliably determined based on the limited testing that was done. A disclaimer will be employed in the report to note that the lead evaluation done is not in complete accordance with the testing protocol in the Massachusetts lead regulations.

Lead-based paint surfaces and components were identified by utilizing on-site x-ray fluorescence (XRF) instruments. EnviroScience Consultants, Inc. owns and maintains two different types of XRFs for testing for lead-based paint. These instruments are four (4) Radiation Monitoring Device LPA-1s (RMD) and a Scitec MAP 4 analyzer. Each of these instruments is operated in accordance with state and federal and manufacturer standards on the use of the instruments.

The federal government has developed Performance Characteristic Sheets (PCS) for each of the types of instruments cited above. Each instrument must be calibrated in accordance with these PCSs on a 1.0 milligram lead standard. Each of EnviroScience's instruments has one of these standards assigned to it. Some of the standards were purchased directly from the government and the others from the manufacturers of the instruments.

Readings (corrected for a substrate contribution, if applicable) of 1.0 mg/cm² or greater are considered to be dangerous levels of lead which must be abated (or in the case of certain metal components, just rendered intact) if a child under the age of six years has access to them and they are either on a defective surface, a chewable surface or a movable/impact surface on window components.

Prior to the start of any testing, a sketch of the building is drawn, and side designations are given to help identify exactly where readings were taken. Drawings depicting the room numbering scheme are located on the cover page(s) for the building(s) inspected. Each side of the building was labeled A, B, C or D. The "A" side of the unit is the side of primary entrance into a dwelling, and this room is always Room 1. Areas in the units include rooms, hallways, and closets. Areas are numbered in a clockwise fashion as building construction allows. This allows the inspector to indicate which substrate surface was tested. The type of hazard (if present) is described by circling the acronym on the testing form.

When more than one surface type was present on a side, the component tested was indicated with a number. If two windows were present on a building side, they were numbered left to right. Closet shelves and shelf supports were numbered top to bottom.

It is understood that the room layouts presented in the report are in conformance with the conditions that exist at the time the testing is performed. EnviroScience avoids labeling a room solely by its current functional use (i.e., living room, bedroom, etc.) since this use can change over time. Similarly, room layouts can change dramatically as dwellings are renovated and additions are built, incorporating existing rooms, or existing interior walls are moved or eliminated altogether.

Appendix E

Lead Testing Field Data Sheets



XRF LEAD SCREENING FIELD DATA SHEET

Inspector: Luigi Marangiello Date: 2/15/13 XRF Model: RMD Serial: 1395
 Project Name: Cambridge City Hall Project Number: 20121733, AIE
 Address: 795 Mass Ave Cambridge, MA Project PM: Bob May

XRF Calibration Check-RMD (0.7 to 1.3 mg/cm² inclusive)

	First Reading	Second Reading	Third Reading	Average
Start Check	1.0	1.0	1.0	1.0
Finish Check	1.0	1.0	1.0	1.0

Room	Side	Surface/Component	Substrate*	XRF Reading	Positive
Sullivan Balcony	B	wall	P	>9.9	Y
	B	curved ceiling	P	>9.9	Y
	B	Ceiling Trim	P	0.2	
		Ceiling Tiles	-	0.0	
		Chair Rail	W	0.4	
		Lower wall	W	0.1	
		Window components	W	0.4	
		Benches	W	0.3	
		Floor	W	0.0	
		Columns	P	>9.9	Y
Sullivan Hall	A-D	wall (upper)	P	01->9.9	Y
	A-D	wall (lower)	W	0.2	
		Council Desk	W	0.2	
	D	Radiator	M	1.1	Y
	B	wall grate	M	8.7	Y
	D	Window sill	W	0.2	
		Window components	W	0.1	
	Ceiling Tiles	-	0.0		
Sophia Anastos	C-D	upper wall	P	0.2	
	ABD	upper wall	D	0.2	
		lower wall	D	0.3	
	C	Window Sill	W	0.3	

* Substrate Type: Metal = M, Wood = W, Plaster = P, Drywall = D, Concrete = C, Brick = B, Aluminum = A
 N/A: Not Accessible; N/C: Not Coated; COV: Covered; VR - Vinyl Replacement, POS = Positive



Project Name: Cambridge City Hall

Project Number: 20121733 A/E

Room	Side	Surface/Component	Substrate	XRF Reading	Positive
Sophia Anastos	C	window Components	W	-0.7	
↓	A	Door	W	-0.3	
	A	↓ Frame	W	-0.8	
Ackerman Room	A-D	Wall	W	-0.5	
↓	A	Window Components	M	<9.9	Y
	A	Radiator	M	0.0	
	A	Window Frame	W	0.2	
	D	Door	W	0.1	
	D	Door Frame	W	-0.6	
	C	Door	W	-0.4	
↓	C	↓ Frame	W	-0.1	
	A-D	Upper wall	D	0.0	
↓		Lower wall	D	-0.2	
		chair Rail	W	0.0	
	C	Door	W	-0.2	
	C	↓ Frame	W	-0.4	
	A	Door	M	-0.5	
	A	↓ Frame	M	-0.3	
Senior Ballroom	A-D	walls	D	-0.2	
↓	A	Door Frame	M	0.0	
	C	Radiator	M	-0.1	
	C	Window Components	M	0.4	
		Column	M	-0.2	
	A	Door	W	-0.2	

* Substrate Type: Metal = M, Wood = W, Plaster = P, Drywall = D, Concrete = C, Brick = B
N/A: Not Accessible; N/C: Not Coated; COV: Covered; VR - Vinyl Replacement, POS = Positive

Appendix F

Hazardous Materials Abatement Cost Estimate

Hazardous Materials Abatement Cost Estimate

A hazardous materials abatement cost estimate is provided below. Unit costs are based on current industry rates and are inclusive of all contractor costs. They do not include costs for design, monitoring, sampling, and other consultant fees.

Table 4
Estimated Cost for Hazardous Materials Abatement

MATERIAL	ESTIMATED QUANTITY	UNIT COST	TOTAL COST
Allowance for (4) floor penetrations (by licensed Asbestos Abatement Contractor) for new installation of electrical conduits, heating risers, etc. as needed		\$750 EA	\$3,000.00
OSHA Lead Compliance during renovation and demolition work		Lump Sum	\$1,000.00
Potential Disposal of Lead Waste from demolition and disposal of removed components and surfaces		Lump Sum	\$1,000.00
SUBTOTAL			\$5,000.00
(~10%) CONTINGENCY			\$500.00
TOTAL			\$5,500.00

APPENDIX B: STUDY PARTICIPANTS

TEAM MEMBERS

Architect

LDa Architecture & Interiors
222 Third Street, Suite 3212, Cambridge, MA 02142
(617) 621-1455

Michael Waters, AIA
Matthew Simitis, AIA, LEED AP BD+C
Peter Makrauer, Associate AIA, LEED AP

Audiovisual & Acoustics Consultant

Acentech
33 Moulton Street
Cambridge, MA 02138
(617) 499-8000

Lawrence Philbrick - Supervisory Consultant
Rosemary Su - Architectural Acoustics
Brian Masiello - Audiovisual Systems Designer

Mechanical, Electrical, Plumbing & Fire Protection Consultant

Building Engineering Resources, Inc.
66 Main Street
Easton, MA 02356
(508) 230-0260

Steven Karan, PE, LEED AP BD+C, Principal

Lighting Consultant

LAM Partners Inc.
84 Sherman Street
Cambridge MA 02140
(617) 354-4502

Keith Yancey, Principal
Jonathan Knickerbocker, Project Manager

Hazardous Materials Consultant

Fuss & O'Neill EnviroScience, LLC
50 Redfield Street, Suite 100
Boston, MA 02122

Dustin Diedrickson, Scientist

Cost Estimating

VJ Associates of New England, Inc.
60 Dedham Avenue
Needham, MA 02492

Clive Tysoe, MRCIS, CCC, Divisional Director
Chris Wong, Senior Cost Consultant

CITY OF CAMBRIDGE

Richard C. Rossi
City Manager

Lisa Peterson
Deputy City Manager

Mary Hart
Director/Chief Information Officer, IT Department

Michael Dugas
Deputy Chief information Officer, IT Department

Michael Muehe
Executive Director, Commission for Persons with Disabilities

Grant Casassa
Production Manager, Office of Cable TV

Paul Lyle
Superintendent of Buildings, Department of Public Works

Charles Sullivan
Executive Director, Cambridge Historical Commission

APPENDIX C: PROCESS DOCUMENTS

City of Cambridge - AV Improvements

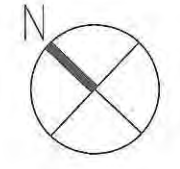
Architectural Scope Matrix



Project Area	Item #	Item Name	Type	Related Scope/Coordination	HIST - REV?	Scope Description	REFERENCE	Deliverable/Representation
Sullivan Chamber	1.00	Cove Acoustic Paneling	ACOUSTIC	Coordinate w/ Acemtech for Fabric Spec	YES	Remove all existing ceiling tile (assumed) substrate. Apply fiber acoustic insulation and stretched fabric-joints to be only at room corners. Color to match existing ceiling color	Acoustic Report - Acemtech Lighting Report - Lam Partners	product spec and coordination with lighting
	1.01	Coffer Acoustic Tile	ACOUSTIC	Coordinate w/ Acemtech for Tile Spec	YES	Remove all existing ceiling tile in coffers. Prepare panels to accommodate ceiling mounted fixtures. Install custom color glass fiber acoustic panels	Acoustic Report - Acemtech	product spec and coordination with lighting proposed finish
	1.02	Fan Coil Grille	ACOUSTIC	Coordinate w/ mech	YES	Remove existing 2' x 4' grille and fan coil units in cavity. Provide required blocking and close cavity with 1/2" plywood and install grille. OR Provide required blocking and close cavity with board and plaster with bead and plaster. Refinish area to match historic stencil	Acoustic Report - Acemtech	narrative description, speaker image, alignment
	1.03	Loudspeakers	AV	Coordinate w/ Acemtech for dims/reqs	YES	Remove existing loudspeakers (4), cabling patch & refinish to match historic stencil. Provide necessary blocking, source equipment cabling, electrical rough-in for power and surface mounting hardware at new column speaker locations. Patch and touch up paint at new mounting locations	AV Report - Acemtech	detail sketch/elevation sketch (BER & LDa)
	1.04	Radiators/Runtal	MEP	Coordinate w/ BER and accessibility project	YES	Provide new radiators along full length of East wall. Radiators to receive custom color. Provide custom perforated metal/historic grill at ramp sidewall	MEP Report - BER City Hall Council Accessibility Project	Elevation or photograph overlay, plan diagram
	1.05	Mezzanine Ceiling Acoustic Paneling	ACOUSTIC	Coordinate w/ Acemtech	YES	Install support framing on existing plaster (assumed) substrate. Apply fiber acoustic insulation and stretched fabric-joints to be only at room corners. Color to match existing ceiling color	Acoustic Report - Acemtech (needs revision on this item)	typ dll or narrative depending on approach
	1.06	AV Integration	AV	Acemtech/Lam Partners	YES	Provide electrical rough in and control wiring to new control locations. Patch and refinish areas of new work	AV Report - Acemtech	AV/Acoustic Report - Acemtech
	1.07	East Windows	AV/ACOUSTIC	Acemtech - fabric requirements	YES	Provide blocking as required. Provide full window height manual velour drapes and refinish areas of new work to match existing	AV/Acoustic Report - Acemtech	Guidelines and/or annotated photos.
	1.08	Clerestory	AV	Acemtech	YES	Provide electrical rough in for power and control wiring. Provide motorized room darkening shades in all clerestory openings (6 double windows). Touch up paint to match existing	AV Report - Acemtech	Mount that keeps monitor back invisible to gallery Paint colors?
	1.09	Device Locations	AV	Acemtech	YES	Remove all existing devices, patch and refinish to match existing. Provide electrical, control and associated cabling at all new device locations. Provide custom color, custom fabricated mounting brackets for all surface mounted devices.	AV Report - Acemtech	
	1.10	Dias Mounted Monitors	AV	Acemtech	YES	Touch up paint to match existing. For councilors 17" (current spec)	AV Report - Acemtech	
	1.11	Ceiling Finish	VARES	Acemtech	YES	Touch up painting at areas of new work to match existing	Acoustic Report - Acemtech	
	1.12	Projector Enclosure	AV	Acemtech	YES	Relocate and provide electrical rough in for existing clock. Provide custom perforated metal enclosure for projector	AV Report - Acemtech	
1.13	Projection Screen	AV	Acemtech	YES	Provide custom perforated metal enclosure for projector screen	AV Report - Acemtech	sketch/precedent photos	
Ackermann Room	2.00	Custom Built in Cabinet	AV	Acemtech & BER?	YES	Remove existing door and partition behind. Provide new partition and sidewalls to create nook	AV Report - Acemtech Lighting Report - Lam Partners	annotated photos, design sketch - wall mounting technique that meets max 4" ADA projection
	2.01	Fiat screen	AV	BER/Acemtech	YES	Provide custom wood cabinet, nook paneling and worktop, finished to match existing panel color. Provide electrical rough in, control and source cabling as required.	AV Report - Acemtech	finish, style, cut, sketch
	2.02	New track and Pendants	Lighting	Lam/ceiling finishes	YES	Provide fixed wall mount, centered in existing paneling. Provide cane rail at floor in area of display. Provide electrical rough in, control and source cabling as required.	Lighting Report - Lam Partners	Attachment type, spec & layout
	2.03	Ceiling Tile	ACOUSTIC	Acemtech, Lam	YES	Install new track lighting with custom color for track and track heads. Provide electrical rough in for new track as required	Acoustic Report - Acemtech Lighting Report - Lam Partners	Sketch, box spec, image
	2.04	Conference Table	AV	Acemtech	YES	Remove all ceiling fixtures. Remove existing acoustic tile. Repair substrate as required. Install new acoustic tile, coordinate with lighting installation. Provide rough in for new floor box with data & power centered under existing table match existing. Install Floor box, patch and repair finish to match existing. Cut in opening to existing table. Install custom color flip up grommet flush on table top. Provide new manual shades in window cavity.	AV Report - Acemtech	
Sophie Anastos Room	3.00	Fiat screen	AV	Acemtech	NO	Provide any additional blocking as necessary for heavy duty drawer slides. Install heavy duty drawer slides. Refinish areas of new work as required	AV Report - Acemtech	finish, style, cut, sketch
	3.01	Room Darkening	AV	Acemtech	NO	Install manual room darkening shades	AV Report - Acemtech	finish, style, cut, sketch (new shade pocket?) image of controls, location, mounting height?
	3.02	New Split System	MEP	BER	NO	Remove existing window AC unit. Re-glaze transom lite at former AC location	MEP Report - BER	Control Locations/Finish
City Hall Annex	4.00	Controls	AV	Acemtech/BER	NO	Replace existing control module. Patch and refinish areas of new work. Provide new LCNF framing if necessary. Patch and refinish area of duct extension. Provide new HVAC grilles	MEP Report - BER	Scope of replaced tiles, new fixtures, diffuser locations?
	4.01	HVAC Renovation	MEP	Acemtech/BER	NO	Remove existing acoustic ceiling tiles and grid. Provide new ceiling grid and new acoustic ceiling tiles. No/variable Partition. Provide required blocking/suspension cables for screen.		Recommendations for improved performance Mounting considerations? Source Equipment location/installation type (rack, hidden, etc.) Speaker finish and installation (recessed?)
	5.00	Ceiling	AC	Acemtech/BER/Lam	NO	Remove existing acoustic ceiling tiles and grid. Provide new ceiling grid and new acoustic ceiling tiles. No/variable Partition. Provide required blocking/suspension cables for screen.		Sketch/Precedent of credenza, control locations & source input location Confirm speaker type and location - both sides of str cur? Verify operation of existing shades
	5.01	Partition	AC	Acemtech	NO	Remove existing acoustic ceiling tiles and grid. Provide new ceiling grid and new acoustic ceiling tiles. No/variable Partition. Provide required blocking/suspension cables for screen.		
	5.02	Projection Screen	AV	Acemtech	NO	Remove existing acoustic ceiling tiles and grid. Provide new ceiling grid and new acoustic ceiling tiles. No/variable Partition. Provide required blocking/suspension cables for screen.		
	5.03	Loudspeakers	AV	Acemtech	NO	Remove existing acoustic ceiling tiles and grid. Provide new ceiling grid and new acoustic ceiling tiles. No/variable Partition. Provide required blocking/suspension cables for screen.		
Lombardi Room	6.00	Fixture layout/type	Lighting	Lam/BER	NO	Remove existing acoustic ceiling tiles and grid. Provide new ceiling grid and new acoustic ceiling tiles. No/variable Partition. Provide required blocking/suspension cables for screen.		Narrative Mounting detail, confirm available depth above x ceiling application
	6.01	Ceiling Tiles	Finish	Lam/BER	NO	Remove existing acoustic ceiling tiles and grid. Provide new ceiling grid and new acoustic ceiling tiles. No/variable Partition. Provide required blocking/suspension cables for screen.	AV - Acemtech	Color choices? Sketch detail of works acoustic mail
	6.02	Projection Screen	AV	Acemtech	NO	Remove existing acoustic ceiling tiles and grid. Provide new ceiling grid and new acoustic ceiling tiles. No/variable Partition. Provide required blocking/suspension cables for screen.		
Water Department	6.03	Acoustic Paneling	AC	Acemtech	NO	Remove existing acoustic ceiling tiles and grid. Provide new ceiling grid and new acoustic ceiling tiles. No/variable Partition. Provide required blocking/suspension cables for screen.		
	7.00	Acoustic Paneling	AC	Acemtech	NO	Remove existing acoustic ceiling tiles and grid. Provide new ceiling grid and new acoustic ceiling tiles. No/variable Partition. Provide required blocking/suspension cables for screen.		

THE GALANTE ARCHITECTURE STUDIO, INC. EXPRESSLY RESERVES THE COMMON LAW COPYRIGHTS IN THESE DRAWINGS. THESE DRAWINGS ARE NOT TO BE REPRODUCED IN ANY MANNER, NOR ARE THEY TO BE ASSIGNED TO A THIRD PARTY WITHOUT THE WRITTEN PERMISSION OF THE GALANTE ARCHITECTURE STUDIO, INC.

THE GALANTE
ARCHITECTURE
STUDIO INC
56 JFK ST CAMBRIDGE, MA 02138
617 576 2500
WWW.GALANTEARCHITECTURE.COM



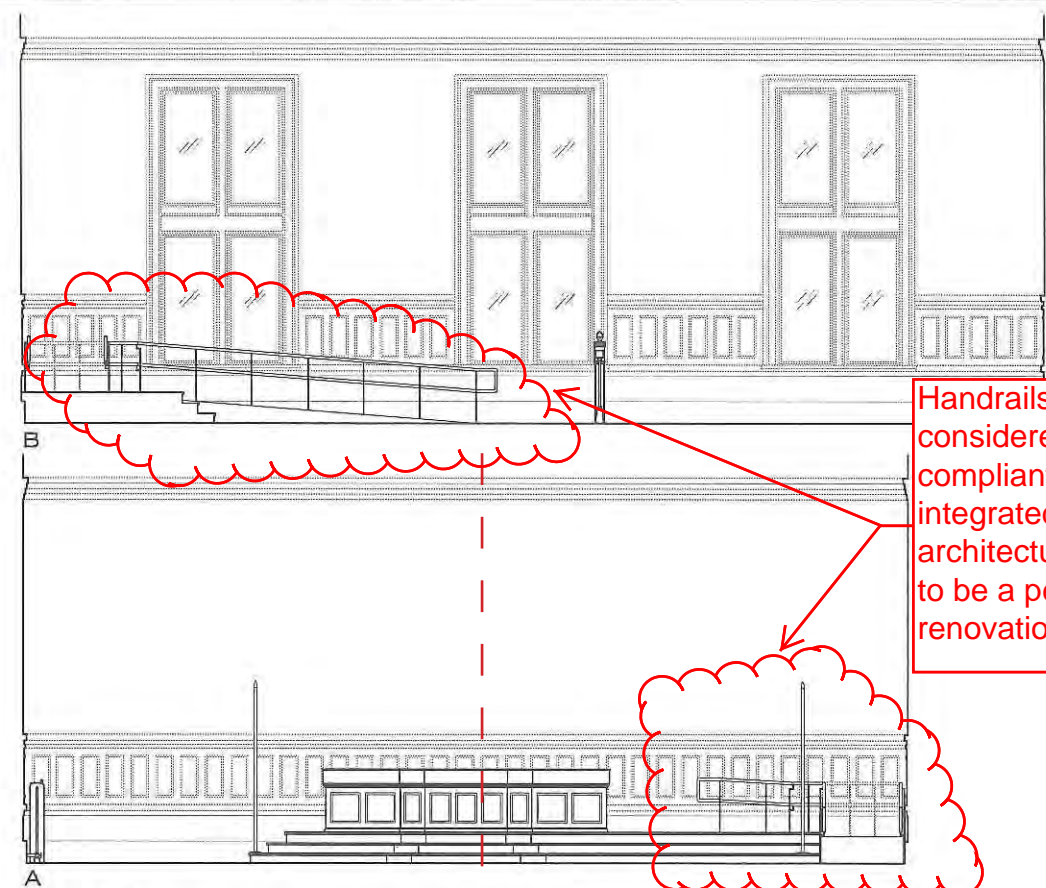
PROJECT NUMBER
1105
PROJECT TITLE
CITY HALL COUNCIL CHAMBERS
ACCESSIBILITY UPGRADE
795 MASSACHUSETTS AVE
CAMBRIDGE, MA 02139

DRAWING TITLE
PLANS & INTERIOR
ELEVATIONS

DATE / ISSUED FOR
03.04.11
SCHEMATIC DESIGN

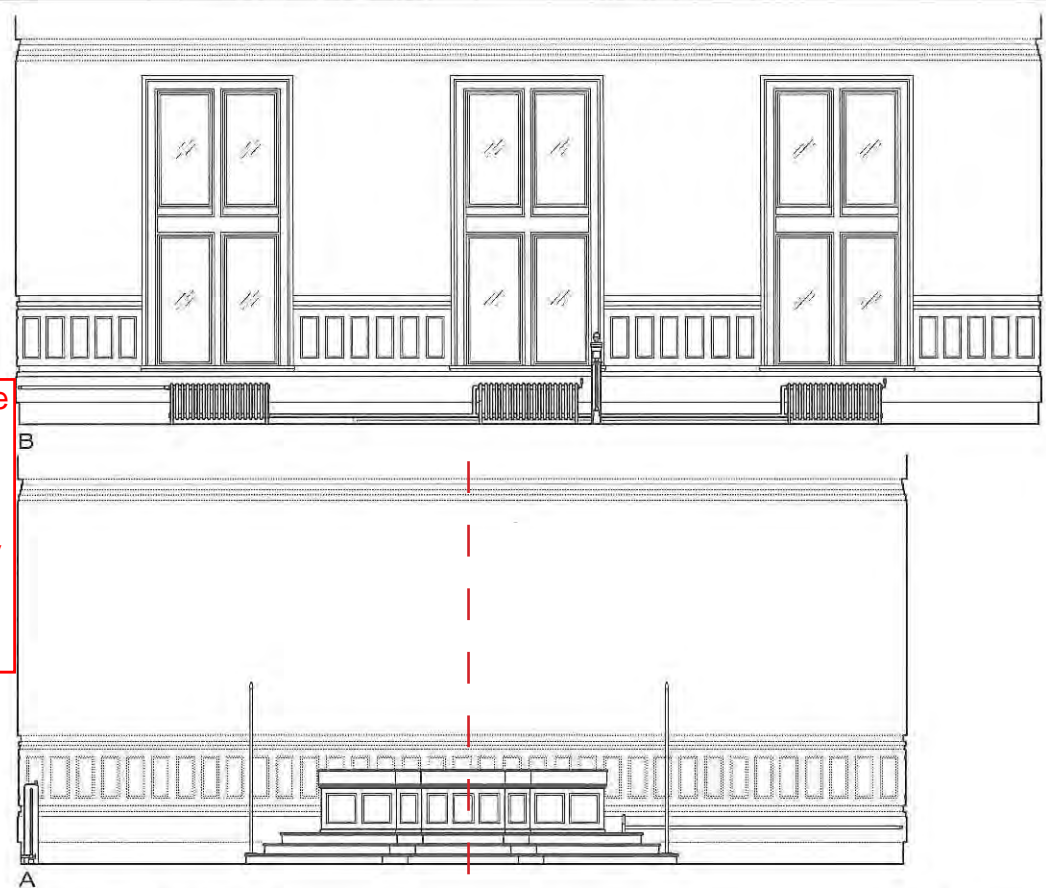
SCALE
AS NOTED
DRAWN BY
EC
DRAWING NUMBER

SD. I

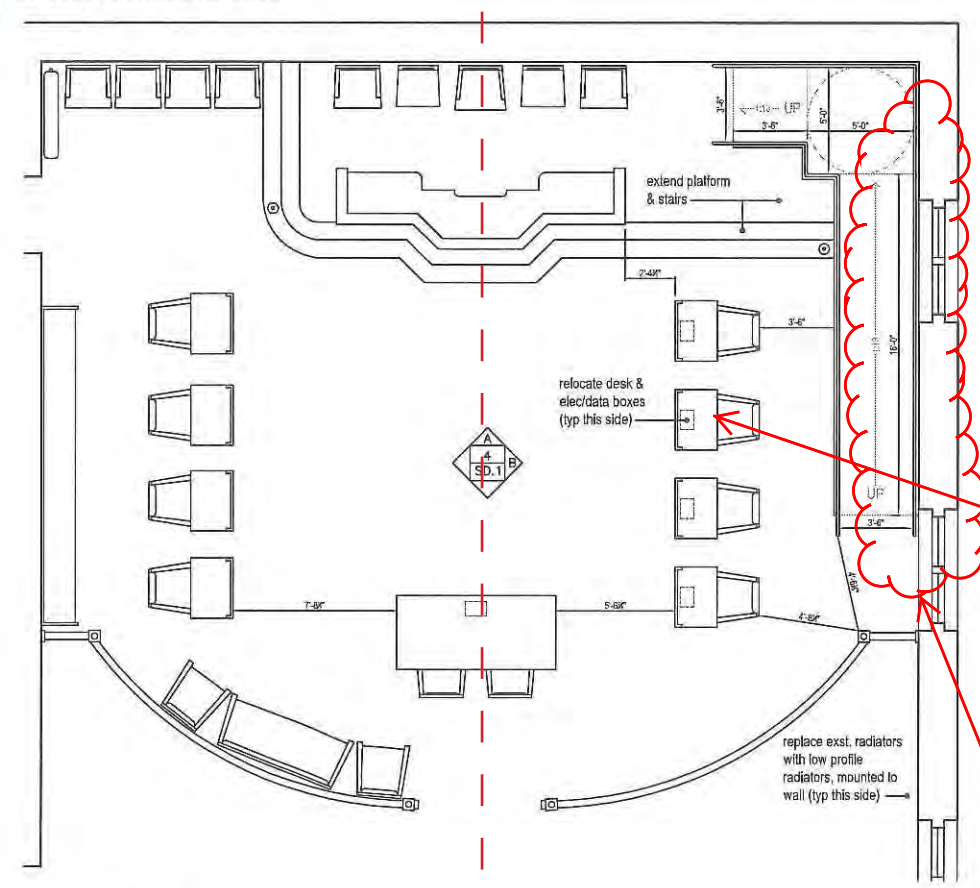


4 RAMP OPTION
INTERIOR ELEVATIONS $\frac{1}{4}'' = 1'-0''$

Handrails should be more considered: code compliant but better integrated into room architecture. This is likely to be a permanent renovation.



2 EXISTING CONDITIONS
INTERIOR ELEVATIONS $\frac{1}{4}'' = 1'-0''$

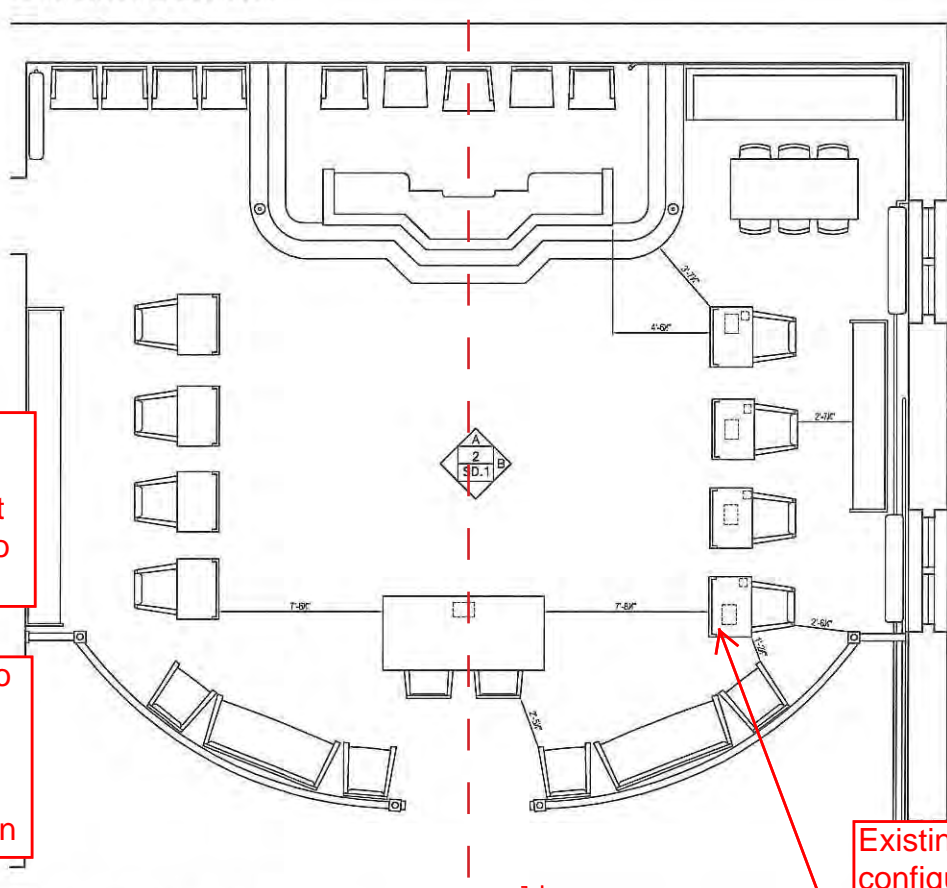


3 RAMP OPTION
PARTIAL SECOND FLOOR PLAN $\frac{1}{4}'' = 1'-0''$

room centerline

Floor boxes will need to be relocated for East councilor desks to shift West

Ramp will need to move 4-6" from exterior wall to allow heating system renovation



1 EXISTING CONDITIONS
PARTIAL SECOND FLOOR PLAN $\frac{1}{4}'' = 1'-0''$

room centerline

Existing configuration provides symmetry for councilor desks

Name	Department	Sullivan Chambers	General questions: how do you use the space? How do you use the space in the next 2 years?	What would you change about the function of this space if you could make changes?	Audio/Visual questions: Do you currently allow video or projection equipment in the space? If so, what do you find interesting about it? If not, what would you like to see change about it? (You can't see it, but you can't see it)	Do you currently use audio equipment or assisted listening technology in this space?	Acoustics: How would you characterize the acoustics in this space? Do you have any concerns about amplified sounds from microphones, speakers, or other? Do you have any concerns about amplified sounds from microphones, speakers, or other? Do you have any concerns about amplified sounds from microphones, speakers, or other?	Additional Comments:
Craig Kelly	City Council	Sullivan Chambers	I would like to be able to use a computer screen in my office. I would like to be able to use a computer screen in my office. I would like to be able to use a computer screen in my office.	I use my City Council make. It seems to work fine for what it is.	NO	NO	Think the acoustics are good.	When we use a screen for a presentation, one side of the room is always facing a steep angle, and the folks in the back of the room are always having a hard time hearing. The way of details because the screen are too far away and too small.
Leland Cheung	City Council	Sullivan Chambers	Better projection. Computer is lagged in to do this. More power.	Ability to project from any desk in the chamber.	NO	NO	Think the acoustics are good.	When we use a screen for a presentation, one side of the room is always facing a steep angle, and the folks in the back of the room are always having a hard time hearing. The way of details because the screen are too far away and too small.
Susan Pacheco	Human Services/COA	N/A						
George Remondes	Electrical Dept	Sullivan Chambers	All equipment that is above the ceiling and below the ceiling. All equipment that is above the ceiling and below the ceiling. All equipment that is above the ceiling and below the ceiling.	There is no equipment in the room. It is not possible to use it. There is no equipment in the room. It is not possible to use it. There is no equipment in the room. It is not possible to use it.	NO	NO	Good	When using the projection equipment seating is an issue see above.
Brad Gerritt	Traffic, Parking and Transportation	N/A						
Renee Sanyalagan	Inspectional Services	Sullivan Chambers						
Maria Velazquez	City Council	Sullivan Chambers	public meetings and if few microphones domestic change	Its cumbersome. Staff doesn't always know how to set up. Could have simple things like remote control	no	no	Good	When the microphones are used, the amplification they provide is not sufficient. Sometimes the sound is too loud. Sometimes the sound is too low. Sometimes the sound is too high. Sometimes the sound is too low. Sometimes the sound is too high. Sometimes the sound is too low. Sometimes the sound is too high.
Ellen Simonoff	Human Services	Sullivan Chambers	All often in meetings that are not mentioned there: committees etc.	not good at all				
Charles Sullivan	Historical	Sullivan Chambers	Sporadic use as a public hearing or for an audience or when the Senator Award. No anticipated changes in use.	More lighting system control. Digital projector and screen.				
Donna P Lopez	City Clerk	Sullivan Chambers	For meetings and hearings. No connections	Nothing is reflective about the current system.	Yes	Yes		
Elizabeth Lint	License Commission	N/A						
Sandra Albano	City Council	Sullivan Chambers	permanent audio visual set up lighting and more air used when mountable set up is requested. Also, to be able to believe this sort of set	Yes. There is nothing reflective with the current system. Would love and updated permanent system	sometimes	sometimes		
Grant Chelasa	Cable TV	Sullivan Chambers	We typically document public meetings in this space by using video/audio devices.	We do. It would benefit the broadcast (and thus the viewer) if we could receive a clean signal from the projector (or laptop) for presentation.	Yes.	Yes.		

General questions: How do you use the space in the next 2 years?	Audio/Visual questions: Do you currently utilize video or audio conferencing in this space? If so, how often and for what purpose? Are recording or amplified sound systems used in this space?	Acoustics: How would you characterize the acoustics of this space? Do you find any echoing or reverberation? Are recording or amplified sound systems used in this space?	Do you currently utilize any technology in this space?	Do you find any echoing or reverberation? Are recording or amplified sound systems used in this space?	Additional Comments:
Ackerly Room	Having a screen with the ability to hook my computer up to it to show graphs and what would be nice	no	no	no	
This space is used for smaller, less formal meetings and conversations	no	no	no	no	Needs projector
NA	Projector screen is not portable either brought in by the sponsor or our IT dept will not have a permanent projection and video system.	Good	No	No	Screen is within Chamber response
NA	smaller (5-15) person meetings seem best suited for this room as we have a lot of people who get staff with higher number of people.		no	The benches around the periphery seem odd when the room is laid out for maximum seating	
NA	Acoustic treatment, when in the room is not very good. Acoustic treatment in the room is not very good.	Acoustic treatment is not very good.	Acoustic treatment is not very good.	Acoustic treatment is not very good.	Benches around Chairs are bulky and need repair. Photo and chairs are important to maintain.
Meeting and hearing room	More accessible internet connections. I am tired of climbing under the desk to plug in the computer.	Occasionally.	Acoustics are adequate.	Acoustics are adequate.	
meetings	lighting - round - more permanent equipment similar to what I see in more of the digital rooms for up rooms	Yes - there really is not system - I would like to see more of the digital rooms for up rooms	fat to poor - if you are not sitting around the table its sometimes difficult to hear	fat to poor - if you are not sitting around the table its sometimes difficult to hear	
We only use this space for our larger events.	We only use this space for our larger events.				

Sophie Aviation Room	General questions: How do you use the space in the next 2 years? What is the most effective use of the space in the next 2 years? What function of the space do you think could make a difference in your use of the space in the next 2 years?	Audio/Visual questions: Do you currently utilize video or audio equipment in this space? If not, what type of equipment do you think you would need? What type of video or audio equipment do you think you would need?	Acoustics: How would you characterize the acoustics of this space? Are there any areas of the room where you would like to improve the acoustics? Are there any areas of the room where you would like to improve the acoustics?	Do you find any seating arrangement or furniture that you like? Are there any areas of the room where you would like to improve the seating arrangement? Are there any areas of the room where you would like to improve the seating arrangement?	Additional Comments:
I almost never use this room.					
NA		The projection equipment no video but video should be added.	good	no	Video conference option would be great in this room.
NA		used AV only once and it worked well.	no problem hearing		In here, it's the chairs that are not great.
NA	small 2-10 person meetings	nothing			
NA	Small meetings, video conferencing, teleconferencing.	Built in laptop or device to read flash drive.	No. It's the most modern setup available in City Hall.	No. Acoustic ceiling technology not available to my knowledge.	Space is tight. Chairs are large and it becomes very crowded if all are in use.
NA	Nothing				Sophie Room is great meeting space.
NA	Meeting room.			No.	

Source Center	Audio/Visual questions: Do you currently utilize video or audio in your meetings? If so, what do you use? Do you have any plans to use any of this technology in the next 2 years?	Why is it not? Is there a specific function of this space that could make change?	Yes, we do currently use video or audio in our meetings. If so, what do you use? Do you have any plans to use any of this technology in the next 2 years?	Acoustics: How would you characterize the acoustics of this space? Do you currently use any audio system or equipment in this space? Are acoustics or amplified sound a problem for you? If so, what would you like to see?	Additional Comments
I don't know how this space could get better, given how big the room is even when cut in half.					
Primary User	The space is used for various meetings, including community meetings, public hearings, and other City Department community meetings. Do not foresee any significant changes in the next 2 years.	We believe it is also possible to use the space for other purposes, but we are not currently planning to do so.	Yes, we do currently use video and audio in our meetings. We use a system of wireless microphones and speakers and a video system. We also have a projector and a screen.	Acoustics are adequate. There is no problem with the acoustics. The room is used for a variety of purposes, including community meetings, public hearings, and other City Department community meetings. Do not foresee any significant changes in the next 2 years.	The ballroom has a variety of uses, including community meetings, public hearings, and other City Department community meetings. Do not foresee any significant changes in the next 2 years.
Main ballroom	Projection is used video should be added	Yes with wireless microphones, speakers, and a video system. We also have a projector and a screen.	good	no as seating is portable	
NA	Video is not used. The same room, and when two different rooms are used, the audio system cannot use the audio system.	NO	Lot of desks in room, when using audio system and microphone is not usable in that capacity	hard to hear, mix room frequently not to work. Side bar conversation are sometimes only 1/2 hear.	could acoustic tiles be used somewhere to help with sound?
NA	The noise of the air system makes it very hard to use	The noise of the air system makes it very hard to use	It would be great to have better built in systems	Why had - need lot of good and better microphone in space	Some of the noise of ballroom has been removed. There have no equipment and not every good electrical and room lighting, etc.
NA	For monthly public hearings usually just using the right side of ballroom with large audience in which case we use the whole ballroom.	Cost of the room, the room is not used after hours. Quiet for air handling. The room is not used for large or direct to read flash drive. Remote control switch to turn on the light during the hearing.	Yes, Xerox offers up of screen and laptops with portable digital projectors. The existing screen is for one side of the room and not the other. We do not have any other technology in the room that we would like to see.	Acoustics are good. It is difficult to hear when the whole room is used. When the whole room is needed, it is difficult to hear when the whole room is used. We do not have any other technology in the room that we would like to see.	Since there are sometimes live meetings, the acoustic tiles have only in the ballroom with divider wall in place. There need to be 2 screens, 2 projectors, split audio system, etc. But audio also need to function as one system for all events. The windows can no longer be opened because of new screens.
NA	we record a number of events in here	We bring our own.	Writing our own.	Hurlable	

What Department	General questions: How do you see the use of the space in the next 2 years? What is the most significant change in your use of the space in the next 2 years? What is the most significant change in the function of this space if you could make changes?	Audio/Visual questions: Do you currently utilize video or audio equipment in the space? If so, how do you use it? Do you have any technology in the space that you would like to add? Do you currently utilize audio equipment in the space? If so, how do you use it? Do you have any technology in the space that you would like to add?	Acoustics: How would you characterize the acoustics of this space? Do you find it easy to hear others in a meeting or conference room? Do you find it easy to hear others in a meeting or conference room? Do you find it easy to hear others in a meeting or conference room? Do you find it easy to hear others in a meeting or conference room? Do you find it easy to hear others in a meeting or conference room? Do you find it easy to hear others in a meeting or conference room?	Do you find any seating arrangements or furniture that is problematic that often?	Additional Comments:
Never used it					
NA					
Conference room second floor/ lunch room 1st floor	Permanent projection and video available in the second floor conference room. The projection system is used in the lunch room. It should be permanent in video should be added.	good	no		The Acoustic space. Really strong City Hall
NA					
NA	The lower lobby is a conference room with small groups and the magnificent lobby for groups.			no	the downtown lobby wasn't created as space where you could see those people. But sure how you can see them. The surfaces for sound to bounce back from. We haven't in my experience solved the problem.
NA					
NA					
NA	We have a couple of events per year here.				We have a couple of events per year here. We have a couple of events per year here. We have a couple of events per year here.