



**THE PORT PREPARDNESS PLAN  
APPENDIX 1**

**GRAY AND GREEN  
INFRASTRUCTURE  
ANALYSES FOR THE PORT**

**CITY OF CAMBRIDGE, MASSACHUSETTS  
05.22.2019**

**Copyright 2018 Kleinfelder  
All Rights Reserved**

**ONLY THE CLIENT OR ITS DESIGNATED REPRESENTATIVES MAY USE THIS DOCUMENT AND ONLY FOR THE SPECIFIC PROJECT FOR WHICH THIS  
REPORT WAS PREPARED.**

## Acknowledgments

### CITY OF CAMBRIDGE

Louis A. DePasquale, City Manager

Lisa C. Peterson, Deputy City Manager

### PROJECT STEERING COMMITTEE

John Bolduc, Environmental Planner, Community Development Department, Project Manager

Iram Farooq, Assistant City Manager for Community Development

Sam Lipson, Environmental Health Director, Public Health Department

Owen O’Riordan, Commissioner of Public Works

Susanne Rasmussen, Environmental & Transportation Planning Director, Community Development Department

Kari Sasportas, Community Resilience & Preparedness Manager

Kathy Watkins, City Engineer, Department of Public Works

### PRODUCED IN COLLABORATION WITH

**Kleinfelder**, Lead Consultant

**Stantec**, for flood modeling of gray and green infrastructure alternatives

[www.cambridge.gov/ClimateChange](http://www.cambridge.gov/ClimateChange)



## Executive summary

The City of Cambridge conducted a Climate Change Vulnerability Assessment (CCVA) to identify areas that are more susceptible to climate risks of flooding and extreme heat. From the CCVA report, the City identified Alewife and The Port as two areas to develop pilot neighborhood plans for climate resiliency. This technical report serves as an appendix to The Port Preparedness Plan report, summarizing the approaches and assumptions to analyze the performance of gray and green infrastructure strategies suitable for The Port neighborhood in the City of Cambridge. Some of the key questions that this study seeks to answer include what types of gray infrastructure strategies can mitigate present and future flooding in The Port, how can green infrastructure strategies be effectively combined with gray infrastructure to mitigate flooding, and to what extent are these green infrastructure strategies successful in terms of mitigating urban heat island (UHI) effect in The Port and improving water quality.

With the City's drainage infrastructure improvements that are currently underway or expected to be constructed by 2020, model results estimated that The Port will see a flood reduction benefit from 5.6 million gallon (MG) (2015 system conditions) to approximately 4.7 MG (2020 system conditions). This implies that approximately 0.9 MG of flood reduction can be achieved from the 2020 system conditions. Among the improvement projects, the stormwater tank at the public Parking Lot #6 (PL6), with a storage capacity of 0.48 MG is the most effective in contributing to the 0.9 MG flood reduction. The City agreed that flood mitigation strategies in The Port at a minimum need to be able reduce the flooding from the 10-year storm by 2070 (4.7 MG), such that the flooding from the 10-year storm by 2070 is no worse than the present 10-year storm (1.2 MG). In other words, the flood reduction strategies need to reduce flooding in The Port by 3.5 MG at a minimum.

Six gray infrastructure alternatives were evaluated for The Port. For all these alternatives, the stormwater tank at Morgan Park with a storage capacity of 0.78 MG and a pumping capacity of 10 MGD is assumed to be implemented, which is estimated to reduce flooding in The Port by 2.6 MG. The incremental flood reduction benefits that gray infrastructure Alternatives 1 through 6 provide over the benefit from the Morgan Park stormwater tank vary from 0.1 MG (Alternative 5) to 0.9 MG (Alternative 4) for the 10-year 24-hour design storm by 2070. Alternative 4, which includes separating the Hampshire Street stormwater catchment area and installing a stormwater storage tank at Donnelly Field, is the best performing alternative in terms of flood reduction. However, conducting sewer separation for a large area such as the Hampshire Street catchment requires significant resources and is likely to cause significant neighborhood impacts, making Alternative 4 less favorable. On the other hand, Alternative 6 includes diverting stormwater flows from The Port south towards the stormwater outfall on Massachusetts Avenue, adding a new 36-inch drain line on Albany Street and repurposing mostly existing/abandoned infrastructure, which makes this alternative more economically favorable and less disruptive to the neighborhood. Hence for this study, Alternative 6 was selected as the most favorable gray infrastructure alternative. The total flood reduction benefit from this alternative is 3.1 MG, of which 2.6 MG reduction is estimated from the Morgan Park stormwater tank and the remaining 0.5 MG reduction is the incremental flood reduction benefit from this alternative.

The selected most favorable gray infrastructure Alternative 6 can reduce flooding in The Port from the 10-year 24-hour storm by 2070 by 3.1 MG, but this is still short of the 3.5 MG reduction that the City agreed upon. Therefore, the City decided to explore green infrastructure opportunities in addition to Alternative 6, such that flooding from the 10-year storm by 2070 is not any worse than the flooding from the present 10-year storm. Five types of green infrastructure strategies practical for The Port were evaluated, which include rain garden, porous pavement, leaching catch basin, tree box filter and green roof.

The combined gray and green infrastructure alternative (Alternative 7) simulates the performance of green infrastructure using a “hybrid approach”. This hybrid approach includes a higher-level implementation level for two selected blocks (referred as “resilient blocks”) in The Port, and a more modest level of implementation outside of the resilient blocks. The total flood reduction benefit from Alternative 7 is 3.6 MG, of which 3.1 MG reduction is estimated from Alternative 6 and the remaining 0.5 MG reduction is the incremental flood reduction benefit from green infrastructure in Alternative 7. This implies that an effective combination of gray and green infrastructure in The Port can successfully compensate for the increased flood volumes due to climate change for some of the smaller more frequent storms, such as the 10-year storms.

Increased trees, green infrastructure and adding white roofs in The Port can also mitigate the UHI effect by lowering the average ambient air temperature in The Port by 2°F. These strategies can also decrease the percent of The Port area experiencing the UHI effect by 15%. In addition, effective implementation of green infrastructure can reduce the total phosphorus loading from The Port by approximately 31 pounds/year, which constitutes of a 15% (area weighted average) removal of total phosphorous. This study demonstrated the effectiveness of a combined gray and green infrastructure alternative to reduce present and future flooding for The Port, mitigate UHI and improve water quality. As next steps, the City will need to further conduct detailed feasibility analysis of the proposed alternative, develop conceptual design and proceed with final design and construction of the strategies in the proposed alternative, if deemed appropriate.



## Table of contents

List of figures.....	2
List of tables.....	4
1 Introduction .....	6
1.1 Existing drainage infrastructure conditions in The Port .....	7
1.2 Updated (2020) infrastructure conditions.....	8
1.3 Key findings from the updated models for The Port .....	9
2 Gray infrastructure.....	15
2.1 Identified gray infrastructure alternatives to test neighborhood-wide flow attenuation/flood reduction.....	15
2.1.1 Alternative 1 – Massachusetts Avenue outfall diversion.....	17
2.1.2 Alternative 2 – Hampshire Street catchment separation .....	21
2.1.3 Alternative 3 – Lechmere system diversion.....	25
2.1.4 Alternative 4 – Hampshire Street catchment separation with Donnelly Field tank.....	29
2.1.5 Alternative 5 – Gold Star Mothers Park stormwater facility.....	32
2.1.6 Alternative 6 – Addition of Albany Street diversion to Alternative 1 .....	35
2.2 Gray infrastructure alternatives key findings .....	39
3 Green infrastructure .....	40
3.1 Types of green infrastructure considered.....	40
3.1.1 Rain gardens.....	41
3.1.2 Porous pavement.....	42
3.1.3 Leaching catch basins.....	43
3.1.4 Tree box filters .....	45
3.1.5 Green roofs .....	47
3.2 Green infrastructure modeling approach.....	48
3.3 Alternative 7 – Combination of gray infrastructure Alternative 6 and green infrastructure hybrid approach.....	52
3.4 Estimated urban heat island benefit from green infrastructure and white roofs.....	54
3.5 Estimated water quality benefits.....	57
3.6 Green infrastructure key findings .....	59
4 Short-duration high-intensity storms analyses.....	60
5 Summary of model results and next steps .....	63

## List of figures

Figure 1 - Map of projects included in the 2020 system conditions model.....	9
Figure 2 – Flood reduction benefits from 2020 system conditions compared to 2015 system conditions (red = areas that no longer flood) under present-day 10-year 24-hour design storm.....	10
Figure 3 – Flood tradeoffs from 2020 system conditions compared to 2015 system conditions (blue = newly flooded areas) under present-day 10-year 24-hour design storm.....	11
Figure 4 – Flood reduction benefits from 2020 system conditions compared to 2015 system conditions (red = areas that no longer flood) under 10-year 24-hour design storm by 2070 .....	12
Figure 5 – Flood tradeoffs from 2020 system conditions compared to 2015 system conditions (blue = newly flooded areas) under 10-year 24-hour design storm by 2070 .....	13
Figure 6 – Flood reduction benefits from Morgan Park stormwater tank (red = areas that no longer flood) under a 2070 10-year 24-hour storm .....	16
Figure 7 – Alternative 1 overview map .....	17
Figure 8 – Flood reduction benefits from Alternative 1 (red = areas that no longer flood) under a 2070 10-year 24-hour storm.....	19
Figure 9 – Flood tradeoffs from Alternative 1 (blue = newly flooded areas) under a 2070 10-year 24-hour storm.....	20
Figure 10 – Alternative 2 overview map .....	22
Figure 11 – Flood reduction benefits from Alternative 2 (red = areas that no longer flood) under a 2070 10-year 24-hour storm.....	23
Figure 12 – Flood tradeoffs from Alternative 2 (blue = newly flooded areas) under a 2070 10-year 24-hour storm .....	24
Figure 13 – Alternative 3 overview map .....	25
Figure 14 – Flood reduction benefits from Alternative 3 (red = areas that no longer flood) under a 2070 10-year 24-hour storm.....	27
Figure 15 – Flood tradeoffs from Alternative 3 (blue = newly flooded areas) under a 2070 10-year 24-hour storm .....	28
Figure 16 – Alternative 4 overview map .....	29
Figure 17 – Flood reduction benefits from Alternative 4 (red = areas that no longer flood) under a 2070 10-year 24-hour storm.....	30
Figure 18 – Flood tradeoffs from Alternative 4 (blue = newly flooded areas) under a 2070 10-year 24-hour storm .....	31
Figure 19 – Alternative 5 overview map .....	32
Figure 20 – Flood reduction benefits from Alternative 5 (red = areas that no longer flood) under a 2070 10-year 24-hour storm.....	33
Figure 21 – Flood tradeoffs from Alternative 5 (blue = newly flooded areas) under a 2070 10-year 24-hour storm .....	34
Figure 22 – Alternative 6 overview map .....	35

Figure 23 – Flood reduction benefits from Alternative 6 (red = areas that no longer flood) under a 2070 10-year 24-hour storm.....	36
Figure 24 – Flood tradeoffs from Alternative 6 (blue = newly flooded areas) under a 2070 10-year 24-hour storm .....	37
Figure 25 – Potential locations to implement rain gardens.....	41
Figure 26 – Impervious pavement surfaces in low/medium-density residential parcels and open spaces.....	42
Figure 27 – Existing catch basins in The Port .....	43
Figure 28 – Leaching catch basin concept design detail .....	44
Figure 29 – Available sidewalks for tree planting .....	45
Figure 30 – Conceptual design detail for tree box-leaching catch basin cross-connection .....	46
Figure 31 – Buildings with flat roofs in The Port.....	47
Figure 32 – Footprint of green infrastructure and blue roofs modeled in the two resilient blocks and their locations.....	49
Figure 33 – Types of green infrastructure considered for The Port (outside the resilient blocks), showing their maximum implementation potential .....	51
Figure 34 – Flood reduction benefits from Alternative 7 (purple = areas that no longer flood) compared to Alternative 5 under a 2070 10-year 24-hour storm .....	53
Figure 35 – Ambient temperature on a 90-degree day in The Port under existing conditions.....	56
Figure 36 – Ambient temperature on a 90-degree day in The Port with improvements from green infrastructure and white roofs.....	56
Figure 37 – Percentage relative contribution of phosphorus removal per green infrastructure type.....	58
Figure 38 – Examples of design storm distribution for short duration, high intensity storms in Metro Boston area .....	61
Figure 39 – Comparison of flood depths and flood elevations between the 10-year 24-hour design storm and the 10-year 2-hour design storm by 2070. ....	62
Figure 40 – Flood volumes for the 10-year 24-hour storm by 2070 for all alternatives .....	64

## List of tables

Table 1 – Comparison of parameters between the 2015 system conditions model and the 2020 system conditions models for the 10-year 24-hour design storm by 2070 .....	14
Table 2 – Comparison of flood reduction parameters for three planning horizons using the 2020 system conditions model .....	14
Table 3 – Comparison of flood volumes for present and 2070 using the 2020 system conditions model and with an underground 0.78MG stormwater tank at Morgan Park.....	17
Table 4 – Summary of total flood volumes within The Port for Alternative 1 under 10-year 24-hour design storm by 2070.....	21
Table 5 – Summary of total flood volumes within The Port for Alternative 2 under 10-year 24-hour design storm by 2070.....	25
Table 6 – Summary of total flood volumes within The Port for Alternative 3 under 10-year 24-hour design storm by 2070.....	29
Table 7 – Summary of total flood volumes within The Port for Alternative 4 under 10-year 24-hour design storm by 2070.....	32
Table 8 – Summary of total flood volumes within The Port for Alternative 5 under 10-year 24-hour design storm by 2070.....	35
Table 9 – Summary of total flood volumes within The Port for Alternative 6 under 10-year 24-hour design storm by 2070.....	38
Table 10 – Summary of total flood volumes for all gray infrastructure alternatives under the 10-year 24-hour storm by 2070.....	39
Table 11 – Types of green infrastructure considered and targeted application for The Port.....	40
Table 12 – Types of green infrastructure and their respective targeted implementation as modeled in the two resilient blocks .....	50
Table 13 – Implementation level and footprint of green infrastructure considered in The Port outside of resilient blocks .....	51
Table 14 – Comparison of Alternatives 6 and 7 with the 2020 system conditions for the 10-year 24-hour design storm by 2070.....	54
Table 15 – Comparison of Alternatives 6 and 7 with the 2020 system conditions for the 10-year 24-hour design storm by 2070.....	54
Table 16 – Summary of metrics contributing to reducing urban heat island impacts .....	55
Table 17 – Summary of impervious area, phosphorus load export rates and annual Total Phosphorous loading from The Port by land use type.....	57
Table 18 – Sample of Total Phosphorous removal calculations by subcatchments .....	58
Table 19 – Comparison of rainfall depths (in inches) for the 2-hour duration design storms in the City of Cambridge .....	60
Table 20 – Results for gray and green infrastructure alternatives compared to the 2020 system conditions for the present 10-year 24-hour design storm .....	63

Table 21 – Results for gray and green infrastructure alternatives compared to the 2020 system conditions for the 2030 10-year 24-hour design storm..... 63  
Table 22 – Results for gray and green infrastructure alternatives compared to the 2020 system conditions for the 2070 10-year 24-hour design storm..... 64

## Attachment

Attachment 1 – Technical memorandum on Flood Mitigation Alternatives for The Port neighborhood...66

# 1 Introduction

This technical report summarizes the gray and green infrastructure strategies for flood mitigation that were analyzed for The Port neighborhood as part of the City’s Climate Change Preparedness and Resiliency (CCPR) Plan. **Gray infrastructure** in this report is defined as traditional engineering systems that generally use concrete, solid plastics, or steel, implemented to manage impacts from natural hazards such as flooding. Gray infrastructure strategies for drainage systems to manage stormwater can include strategies that mitigate flooding by either detaining water, such as large storage tanks and/or by draining floodwaters away from flooded areas as quickly as possible, such as larger pipes and pump stations. **Green infrastructure** is a term that can encompass a wide array of best practices combining the natural and built environments to manage impacts from flooding and heat, improve water quality, and enhance the cityscape.

A similar technical appendix titled “Green Infrastructure Analysis and Urban Heat Island Modeling” was published as part of the Alewife CCPR Plan, which focused on answering the City’s questions on the extent to which the natural environment and engineered ecosystems can be effectively used to mitigate precipitation flooding and increased urban heat island effects<sup>1</sup>. However, The Port neighborhood is very different compared to Alewife in terms of demographic trends, land-use distribution and development opportunities. Also, The Port is very dense with underground infrastructure systems and prone to flooding issues related to both stormwater and combined wastewater. Therefore, the City deemed it important to analyze flood mitigation options for this neighborhood that combine both gray and green infrastructure strategies. The City has several planned gray infrastructure improvements projects in The Port neighborhood and surrounding areas to mitigate flooding. This report evaluates some of these proposed improvements through the gray infrastructure alternatives analyses and assesses their effectiveness to mitigate flooding from future storms, such as the 10-year 24-hour storm by 2070. A unique contribution of this report is that it evaluates the selected most promising gray infrastructure alternative with an effective combination of green infrastructure strategies unique to The Port and assesses the efficacy of this combination in terms of flood reduction, urban heat island (UHI) reduction and improvements to water quality.

Another unique component of this report is the flooding analysis in The Port from short duration high intensity storms and a preliminary evaluation of potential options to address this type of flooding. Historically, these types of storms have caused significant flood damages in The Port. Also, these types of storms require different flood mitigation solutions compared to the standard 24-hour storms and need to be more focused on inlet capacity improvements. This report evaluates the selected most promising gray infrastructure alternative for the 24-hour storm in combination with additional inlet capacity improvements to assess the efficacy of this combination for the 10-year 2-hour storm by 2070.

---

<sup>1</sup> CCPR Appendix B available at:  
[https://www.cambridgema.gov/CDD/Projects/Climate/~/\\_media/E793050A9B0F48ABBFFBF52924A5D58B.ashx](https://www.cambridgema.gov/CDD/Projects/Climate/~/_media/E793050A9B0F48ABBFFBF52924A5D58B.ashx)

To identify the best combination of gray and green infrastructure strategies for The Port, the City posed the following questions:

1. How can gray infrastructure in The Port be improved to mitigate future flood volumes, such that flooding from the 10-year 24-hour storm by 2070 is not exacerbated compared to the present day 10-year 24-hour storm?
2. How effective are green infrastructure strategies in combination with gray infrastructure to mitigate future flood volumes in The Port?
3. How effective are the green infrastructure strategies in terms of mitigating UHI in The Port and improving water quality?
4. What types of gray infrastructure solutions can mitigate flooding from high-intensity short duration storms in The Port?

### 1.1 Existing drainage infrastructure conditions in The Port

The current drainage system in The Port has a mix of separated and combined drainage system with cross connections between the two systems. The drainage system for Bishop Allen Drive and Washington Street has dedicated storm drain pipes to carry stormwater flows, but ultimately joins a combined sewer pipe downstream on Portland St. Harvard Street also has dedicated storm drain pipes, but there are common manholes along the entire length of the street that cross-connect the dedicated storm drains to parallel sewer pipes. The characteristics of shared conveyance capacity between the drainage and sewer systems classify most of The Port be a combined drainage area.

Once the stormwater flows discharge into the downstream combined sewer pipe on Portland Street, the pipe carries flows to Massachusetts Water Resources Association (MWRA)'s Prison Point Combined Sewer Overflow (CSO) Treatment facility. Along Portland street, this combined sewer pipe is also cross-connected to the parallel MWRA's Cambridge Branch Sewer interceptor.

During major storms, the Cambridge Branch Sewer interceptor and the Portland Street combined sewer system are both surcharged. The Portland street combined sewer will continue to carry the flows via the Binney Street combined sewer system and relieve the surcharged flows at the CSO outfall CAM017. Due to the hydraulic restrictions in the combined sewer system, the upstream low-point at the intersection of Bishop Allen Drive and Columbia Street experiences the most severe flooding. Other areas include the intersection of Broadway and Hampshire Street.

The downstream end of the combined drainage area is connected to the MWRA sewer network that ultimately carries sewage to the Deer Island Wastewater treatment plant. During intense rainstorms, the MWRA is expected to be at capacity, and this restricts the combined drainage system in The Port, resulting in major flood impacts in several areas within The Port.

The 10-year 24-hour design storms for present, 2030 and 2070 were modeled using the City's hydrologic/hydraulic (H/H) 2-D model developed by Stantec using ICM-2D. The H/H model for The Port neighborhood is included within the Charles River sub-basin model of ICM. Since the City published the results of this model for the Charles River sub-basin model as part of the Climate Change Vulnerability Assessment (CCVA) completed in 2015<sup>2</sup>, the H/H model was updated to include more recent input datasets available. This updated model is henceforth referred in this report as the "2015 system conditions model" and includes the following updates:

- The Charles River cross-sections and bathymetry were integrated into the 2D model as opposed to using a reservoir model for the River in the previous version.
- Ground elevation data updated to include the 2014 Pictometry LiDAR data.
- For stormwater flows from the Boston side, the actual H/H model by the Boston Water and Sewer Commission (BWSC) was run for the different storms as opposed to using unit hydrographs in the previous version.
- Includes the 2015 model updates by the Massachusetts Water Resources Authority (MWRA) and important updates from the 2017 MWRA model with respect to Cottage Farm operations.
- Model recalibration results against newly available observed data at multiple locations.

The 2015 system conditions model was run using ICM 2D for the 10-year 24-hour storms for present, 2030 and 2070 planning horizons, and the flood maps are illustrated in Appendix B (pages 25 through 27) of Attachment 1 technical memo by Stantec titled "Flood Mitigation Alternatives for The Port neighborhood".

## 1.2 Updated (2020) infrastructure conditions

In addition to the updates made as part of the 2015 system conditions model, several other drainage infrastructure improvements projects are either being constructed by the City or are in the final stages of design and expect to be completed by 2020 in The Port neighborhood and surrounding areas. To better reflect system conditions in The Port in the short term, the model was updated to incorporate the on-going projects listed below. This updated model is henceforth referred in this report as the "2020 system conditions model" and includes the following projects, which are also shown in Figure 1:

- Parking Lot 6 (PL6) stormwater tank and pump station, estimated completion August 2020.
- Sewer separation of the area along Cardinal Medeiros Avenue between Binney Street and Cambridge Street (Project 9ab) with estimated completion February 2019
- Monsignor O'Brien (MOB) new drain and new Lechmere Canal outfall, estimated completion August 2019
- First Street and Third Street sewer separation south of Binney Street

---

<sup>2</sup> CCVA Report Part 1, Appendix A available at:

<https://www.cambridgema.gov/CDD/Projects/Climate/~media/CEECF015AB2645C1811C33F707CEA85A.ashx>



- Talbot Street storm drain and outfall, estimated completion Jan 2020
- Cottage/Lopez sewer separation, estimated completion January 2020
- Upsizing Broad Canal drain from 54 to 72 inches from the Broad Canal outfall to the end-of-line at Galileo Galilei Street
- Rogers Street sewer separation between First and Third streets
- Willard St project sewer separation and new stormwater outfall
- CAM05 outfall pipe was adjusted to reflect sedimentation cleaning



Figure 1 - Map of projects included in the 2020 system conditions model

### 1.3 Key findings from the updated models for The Port

Based on using the 2015 system conditions model, the 10-year 24-hour design storm by 2070 results in 5.6 million gallons (MG) of total flood volume within The Port neighborhood. Using the 2020 system conditions model for the same 10-year storm by 2070 results in 4.7 MG of total flood volume. This implies that the drainage improvements reflected in the 2020 system conditions model contribute to approximately 0.9 MG of flood reduction. This flood reduction can largely be attributed to the addition of the Parking Lot 6 (PL6) stormwater tank, which is 0.48 MG in capacity and other drainage improvements in the Cambridgeport area that were considered in the 2020 system conditions model. The PL6 tank attenuates significant flood volume in The Port by detaining stormwater, and drainage

improvements in the Cambridgeport area allow the tank to discharge the stored volume with minimized hydraulic restrictions.

Figure 2 and Figure 3 show comparisons of model results between the 2015 system conditions and the 2020 system conditions for the present-day 10-year 24-hour design storm. In Figure 2, the red areas correspond to areas where flooding is likely to be eliminated under the 2020 system conditions compared to the 2015 system conditions. In Figure 3, the blue areas correspond to areas where additional flooding is likely under the 2020 system conditions compared to the 2015 system conditions. Figure 4 and Figure 5 show similar comparisons of model results between the 2015 system conditions and the 2020 system conditions for the 10-year 24-hour design storm by 2070.

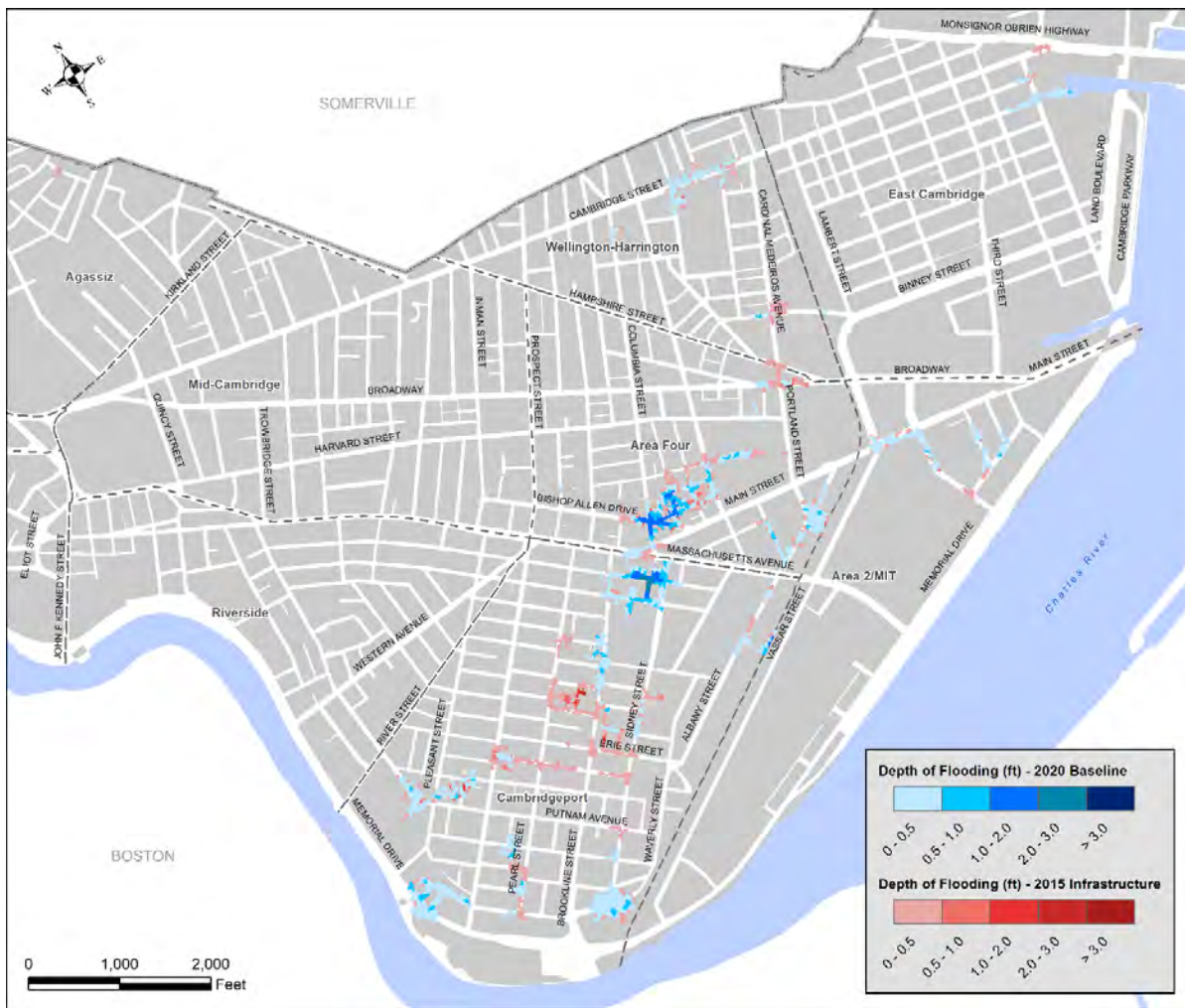


Figure 2 – Flood reduction benefits from 2020 system conditions compared to 2015 system conditions (red = areas that no longer flood) under present-day 10-year 24-hour design storm



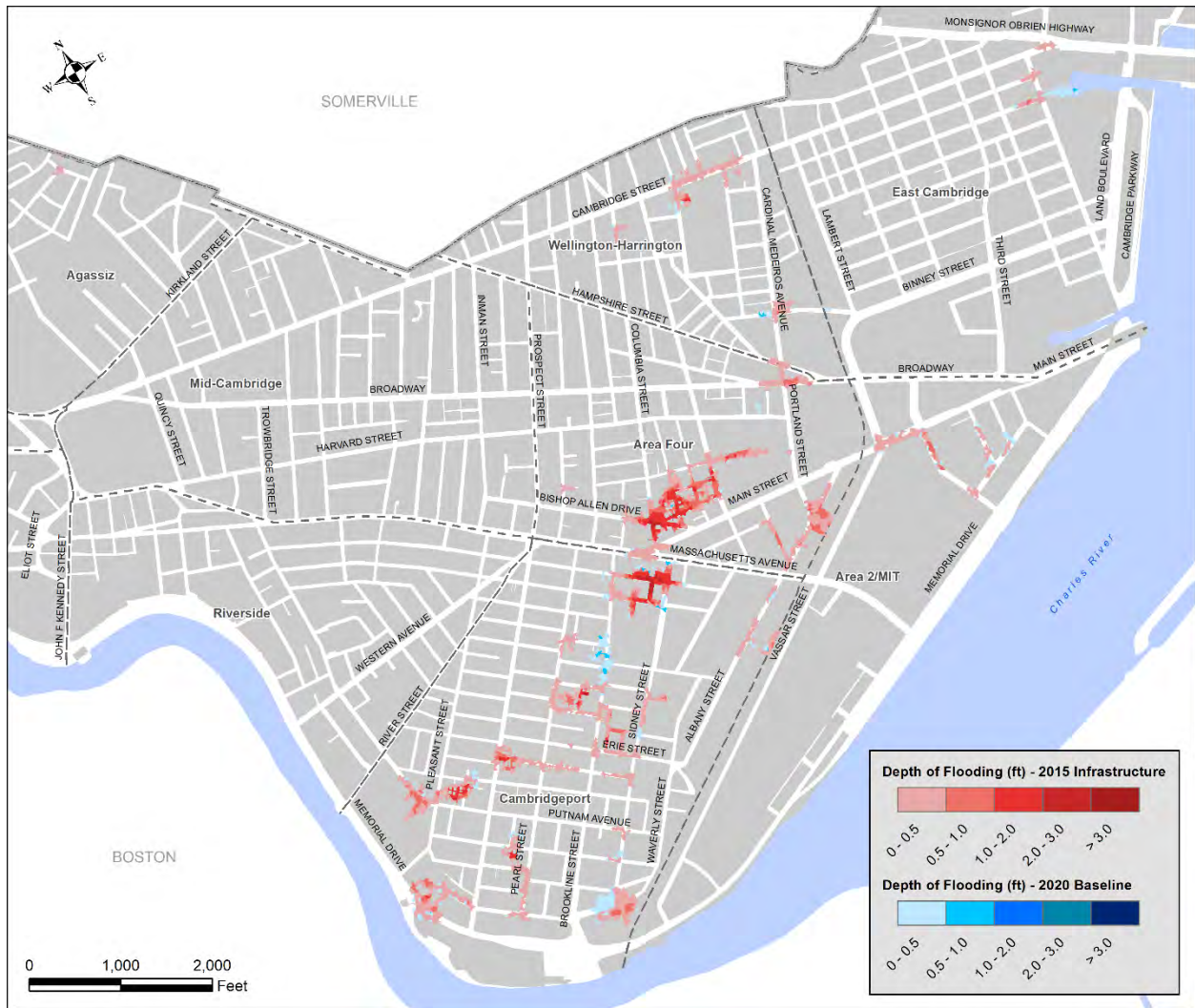


Figure 3 – Flood tradeoffs from 2020 system conditions compared to 2015 system conditions (blue = newly flooded areas) under present-day 10-year 24-hour design storm

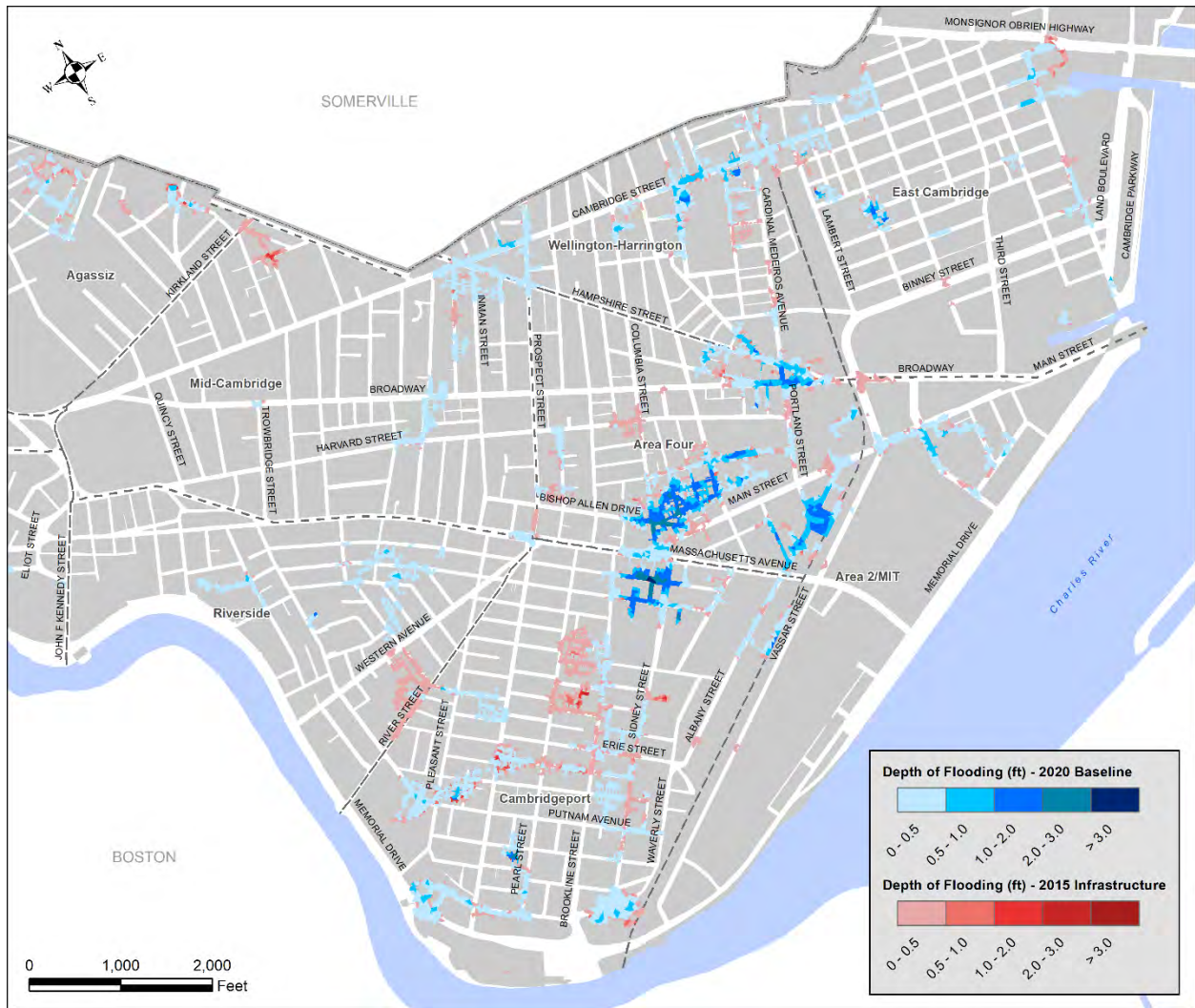


Figure 4 – Flood reduction benefits from 2020 system conditions compared to 2015 system conditions (red = areas that no longer flood) under 10-year 24-hour design storm by 2070



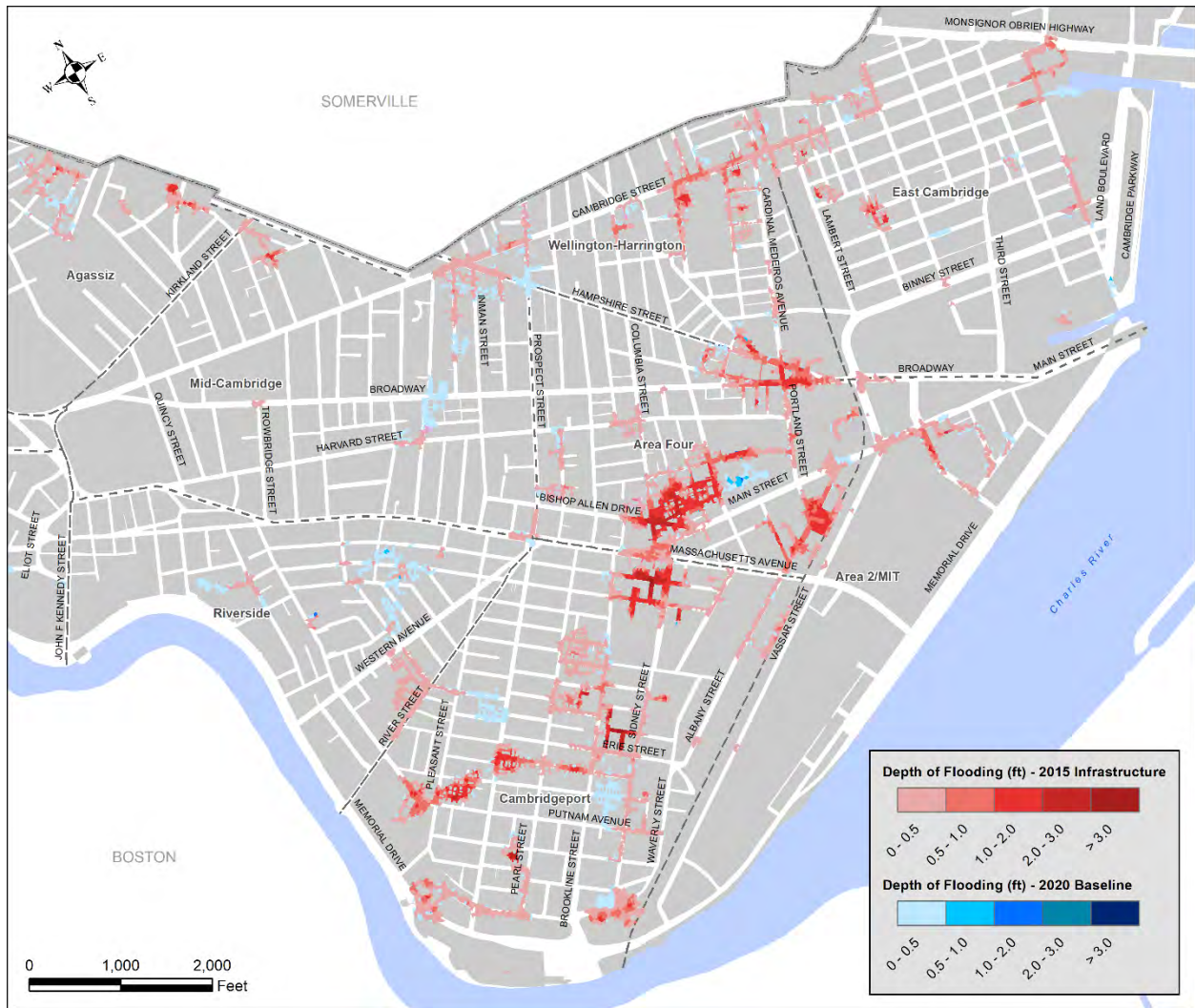


Figure 5 – Flood tradeoffs from 2020 system conditions compared to 2015 system conditions (blue = newly flooded areas) under 10-year 24-hour design storm by 2070

Table 1 presents the comparison between the 2015 system conditions and the 2020 system conditions with respect to flood volume, percentage of area flooded, and percentage of properties flooded in The Port. This implies that the near term drainage improvement projects by the City that are in construction and likely to be finished by 2020 can reduce the flood volume by 0.9 MG, reduce the flooded area by 3% (red areas in Figure 3) and reduce the number of properties flooded by 11% in The Port for the 10-year storm by 2070.

*Table 1 – Comparison of parameters between the 2015 system conditions model and the 2020 system conditions models for the 10-year 24-hour design storm by 2070*

Parameter	2070 10-Yr, 24-Hr storm 2015 Infrastructure	2070 10-yr 24-Hour storm 2020 Infrastructure
Flood Volume (MG)	5.6	<b>4.7</b>
% Port Area Flooded	18%	15%
% Port Properties Flooded	40%	29%

Table 2 summarizes the flood volumes, percent of The Port area flooded and percent of properties in The Port flooded under the 10-year 24-hour storm for present, 2030 and 2070 planning horizons using the 2020 system conditions model. The present day 10-year storm results in 1.2 MG of flooding in The Port. The City’s current infrastructure (that is already built or currently being built) in The Port can mostly manage the flooding from this 1.2 MG. As climate change causes more intense and frequent rain events in the future, the 10-year storm by 2070 (similar to the present day 25-year storm) can result in significantly higher flood volume of 4.7 MG. It was decided that the **flood mitigation strategies in The Port at a minimum need to be able reduce the flooding from the 10-year storm by 2070 (4.7 MG), such that it is not any worse than the flooding from the present 10-year storm (1.2 MG)**. In other words, flood mitigation strategies in The Port need to **capture or manage the difference between 4.7 MG and 1.2 MG, which is 3.5 MG of flood volume**.

*Table 2 – Comparison of flood reduction parameters for three planning horizons using the 2020 system conditions model*

Parameter	Present-Day 10-Yr 24-Hr	2030 10-Yr 24-Hr	2070 10-Yr 24-Hr
Flood Volume (MG)	1.2	2.6	4.7
% Port Area Flooded	6%	10%	15%
% Port Properties Flooded	15%	22%	29%

## 2 Gray infrastructure

The City of Cambridge has invested in several large-scale gray infrastructure projects in The Port neighborhood that will be completed by 2020 to improve the existing drainage system. As part of the CCPR Port Plan, the City also evaluated additional gray infrastructure alternatives that increase the storage/conveyance capacity of the drainage system in The Port to reduce flooding impacts from climate change. These alternatives are high-level conceptual plans with an implementation timeframe for Year 2030 and onwards, when it is expected that the City will experience more frequent and intense storms<sup>3</sup>. The alternatives are based on various studies conducted by the City in the last ten years to reduce flooding in the City within the Charles River sub-basin, which includes The Port. These studies include but are not limited to the following:

- 2006 CAM017 Facilities Plan Report
- 2013 Phase 1 and Phase 2 of the East Cambridge Incremental Hydraulic Improvement Program
- 2016 East Cambridge and Cambridgeport Infiltration/Inflow Gray Infrastructure Mitigation Alternatives
- 2016 Broadway storm drain upsizing analysis
- 2017 Inflow/Infiltration Management Program Technical Memorandum – Task 1: Review and Compile Sewer System Assessments
- Cambridge DPW Project 9ab Specifications

Based on the information provided from the reports and feedback received from the City, Kleinfelder and Stantec identified eight independent gray infrastructure options that can potentially mitigate flooding in The Port. In addition to referencing past reports, four new options were explored based on known opportunities that include open spaces, public right of way and redevelopment plans. So, a total of 12 independent options were discussed to mitigate flooding in The Port.

### 2.1 Identified gray infrastructure alternatives to test neighborhood-wide flow attenuation/flood reduction

Among these 12 options, projects were grouped into six alternatives. The grouping of the projects was based on considerations, such as proximity to known flood areas, feasibility of construction, and interconnectivity in the drainage system. The performance of these alternatives was evaluated in the City's hydraulic model to simulate flood reduction benefits that each alternative can provide.

According to the 2017 Inflow/Infiltration Management Program Technical Memorandum, it was recommended that the implementation of a 0.78 MG stormwater tank at Clement Morgan Park is highly effective in reducing flood impacts for The Port area. Therefore, this stormwater tank at Clement Morgan Park was included for all the proposed gray and green infrastructure alternatives evaluated in this technical report. Figure 6 shows the location of the Morgan Park stormwater tank and its associated

---

<sup>3</sup> CCVA Report Part 1 –Precipitation, [https://www.cambridgema.gov/CDD/Projects/Climate/~/\\_media/307B044E0EC5492BB92B2D8FA003ED25.ashx](https://www.cambridgema.gov/CDD/Projects/Climate/~/_media/307B044E0EC5492BB92B2D8FA003ED25.ashx), Page 12

flood reduction benefits for a 10-year 24-hour storm by 2070. Table 3 compares the flood volumes in The Port under the present and the 2070 10-year storms using 2020 system conditions and the 2070 10-year storm under the 2020 system conditions plus the stormwater tank at Morgan Park. Table 3 concludes that the Morgan Park stormwater tank can reduce flooding in The Port from 4.7 MG to 2.1 MG (2.6 MG of flood reduction) for the 10-year 24-hour storm by 2070.

Sections 2.1.1 through 2.1.6 describe the gray infrastructure alternatives considered in addition to the Morgan Park stormwater tank. These alternatives are also discussed in Attachment 1 technical memo by Stantec titled “Flood Mitigation Alternatives for The Port neighborhood”.

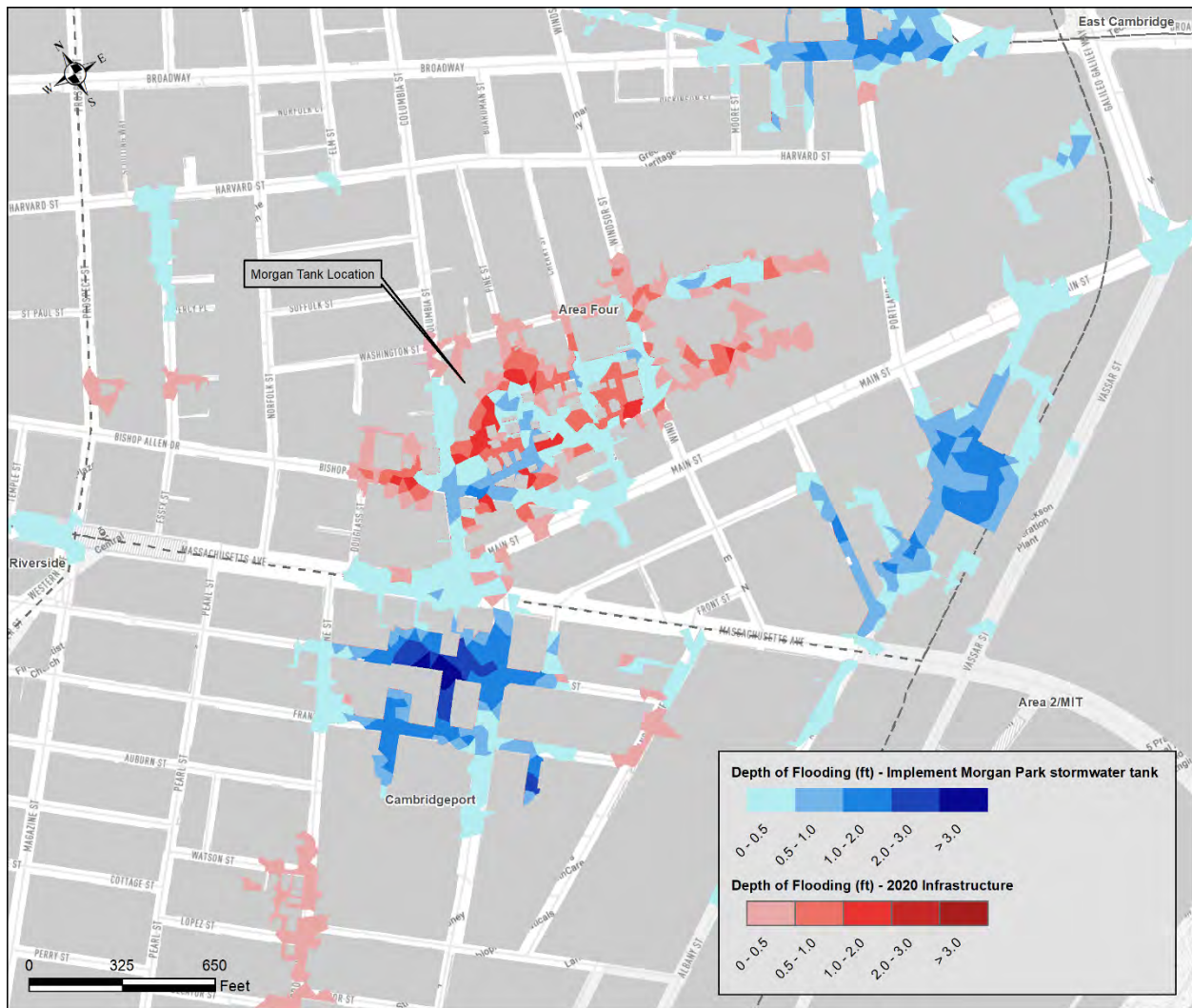


Figure 6 – Flood reduction benefits from Morgan Park stormwater tank (red = areas that no longer flood) under a 2070 10-year 24-hour storm



Table 3 – Comparison of flood volumes for present and 2070 using the 2020 system conditions model and with an underground 0.78MG stormwater tank at Morgan Park

Parameter	Present-Day 10-Yr 24-Hr under 2020 system conditions	2070 10-Yr 24-Hr under 2020 system conditions	2070 10-Yr 24-Hr under 2020 system conditions + Morgan Tank
Flood Volume (MG)	1.2	4.7	2.1

### 2.1.1 Alternative 1 – Massachusetts Avenue outfall diversion

Gray infrastructure modifications for Alternative 1 (illustrated in Figure 7), include that all of Harvard Street within The Port will be modified to become two fully separated sewer/drain system. This can be achieved by performing an Illicit discharge detection and elimination (IDDE) program and removing all the common manholes that currently cross-connect the two systems. A backflow preventer will be installed on the Binney Street combined sewer at the Broadway intersection to prevent backflows from the Binney street combined sewer to The Port and a junction structure at the intersection of Main St and Portland St will be reconfigured and connected to an existing functional 42” siphon that may be rehabilitated to facilitate this alternative. An existing combined sewer pipe that runs along Portland and Albany St between Main St and Mass Av will be repurposed to a stormwater drainage pipe connecting the junction structure and Mass Ave Drain.



Figure 7 – Alternative 1 overview map

This setup will turn most of The Port area to be a separated drainage area as a significant portion of the common manholes are removed. Main Street will remain as a combined sewer area as the common manholes will remain in place. The stormwater flows in these pipes will continue to discharge into the Binney Street combined sewer for flows on the north side of Main Street. For stormwater flows on the south side of Main Street, the flows will be discharged into the North Charles Relief Sewer. In the separated area, flows will be collected in the dedicated drain pipes. Under normal conditions, flows will be directed northward until the Binney Street Sewer is surcharging and the flap valve at the backflow preventer closes. In that case, flows will be directed southward to the 42"-siphon, allowing flows to go under the Red line subway tunnel, discharging into the junction structure. The junction structure continues to direct flows southward into the repurposed drain pipe, ultimately merging the flows in the Massachusetts Avenue drainage system and discharge into the Charles River at the Massachusetts Avenue stormwater outfall.

Figure 8 shows a comparison of flood depths and extent between Alternative 1 (blue layer) and the 2020 system conditions (red layer) for the 10-year 24-hour design storm by 2070. The uncovered red areas in this figure represent those that are likely to experience no flooding under Alternative 1 compared to the 2020 system conditions (e.g., areas on Bishop Allen Drive and east of Colombia Street). The intersection of Broadway and Hampshire Street saw no improvements. This is expected because the intention of Alternative 1 is to redirect stormwater flows from the Harvard Street area southward to the drainage system on Massachusetts Avenue. In this alternative, stormwater flows on Broadway will remain to drain towards the CAM017 combined sewer overflow via the Binney Street combined sewer.

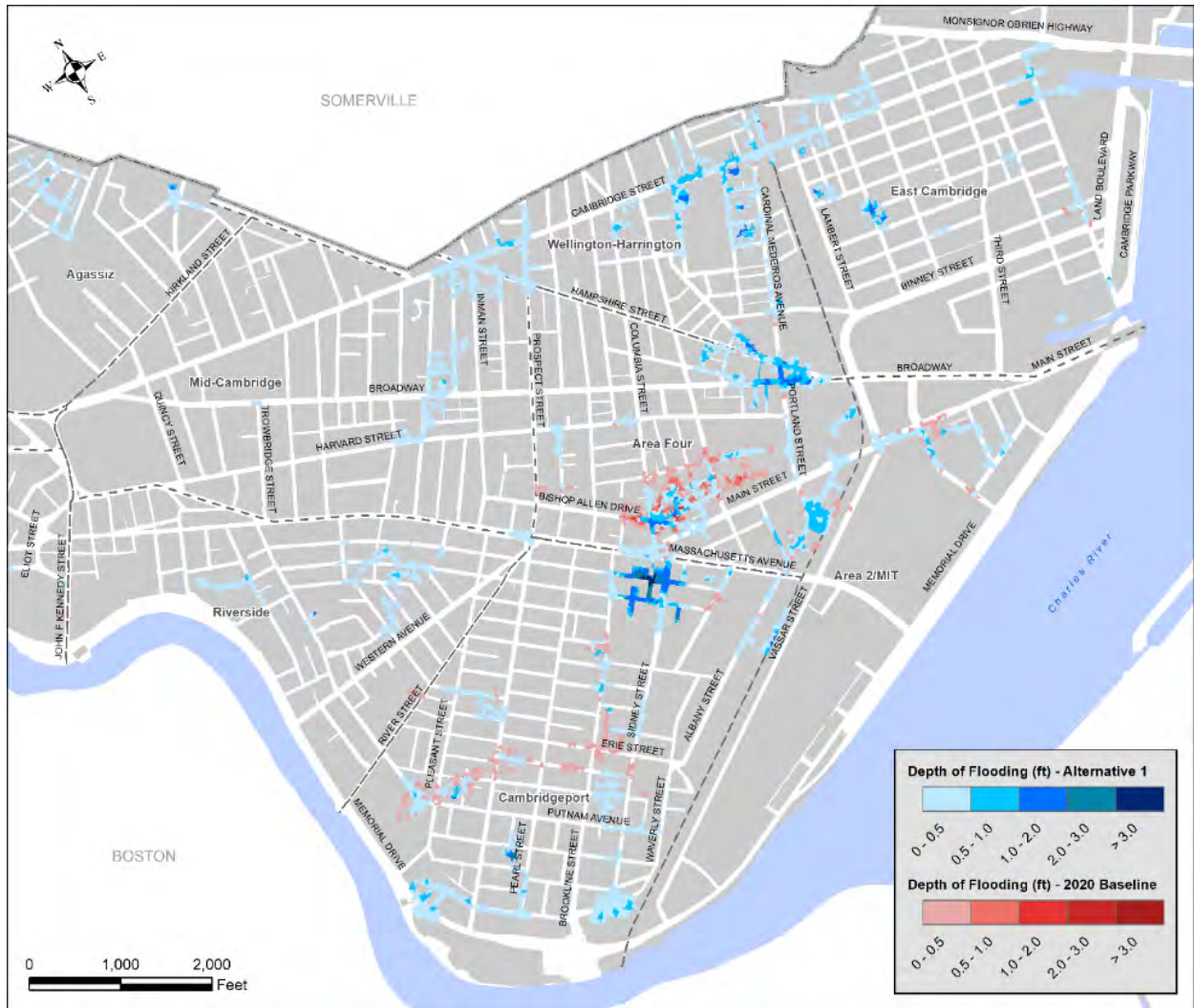


Figure 8 – Flood reduction benefits from Alternative 1 (red = areas that no longer flood) under a 2070 10-year 24-hour storm

Figure 9 presents the same comparison with the top and bottom layers in the reversed order. The uncovered areas in blue color show locations where the model identified new flood areas because of implementing Alternative 1. This alternative includes a backflow preventer installed at the intersection of Broadway and Portland St to prevent downstream sewer flows from backing up into the upstream separated system. This modification creates a restriction to stormwater flows north of Broadway, which is highlighted by the darker blue area north of The Port.



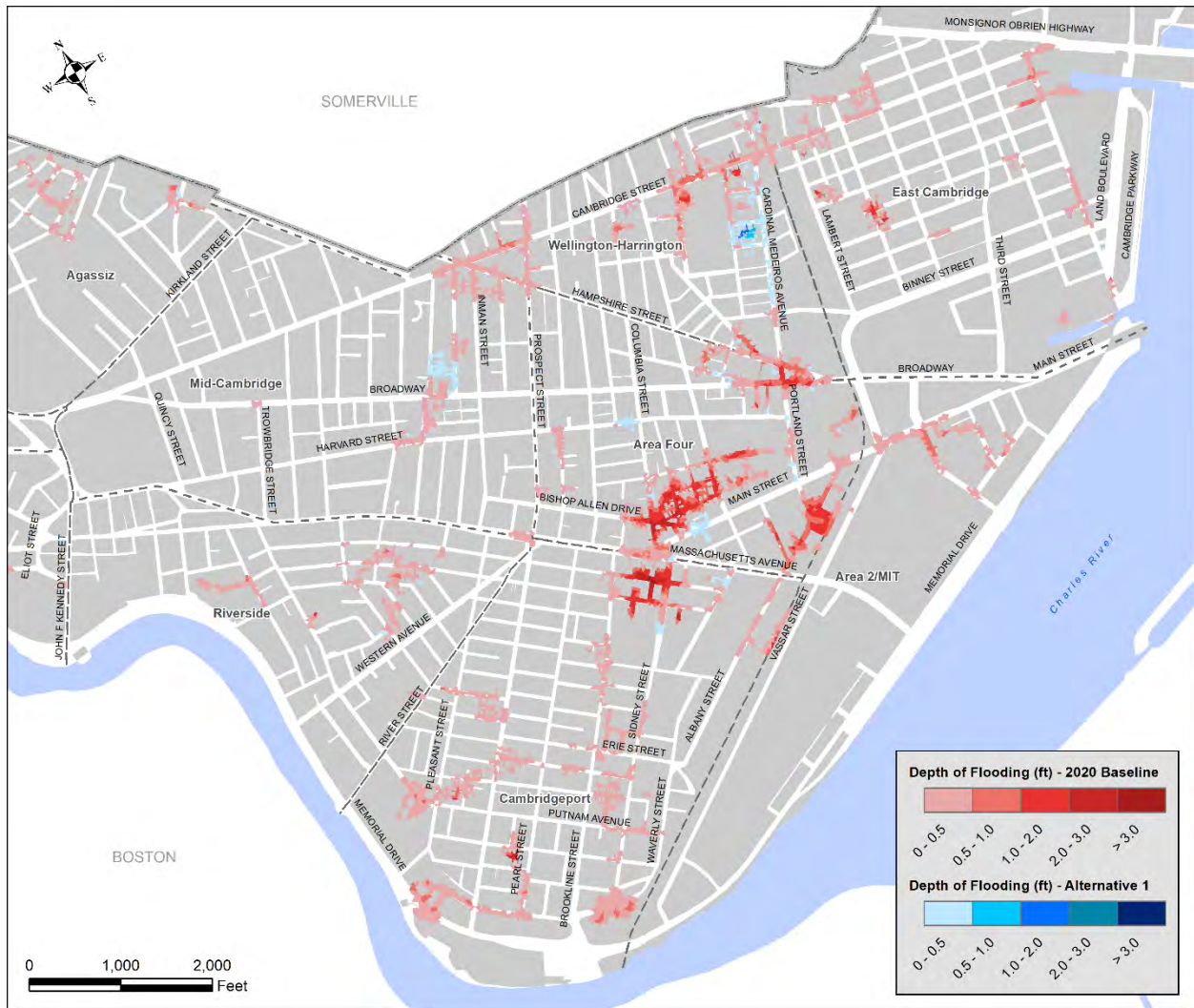


Figure 9 – Flood tradeoffs from Alternative 1 (blue = newly flooded areas) under a 2070 10-year 24-hour storm

Table 4 compares the flood volumes *only within The Port area*. **Alternative 1** is expected to provide a flood reduction of approximately 2.9 MG, a **62% flood volume reduction** under the 10-year 24-hour storm by 2070. Of the total 2.9 MG of flood reduction, 2.6 MG flood reduction can be attributed to the Morgan Park stormwater tank. Therefore, approximately 0.3 MG of flood reduction can be attributed to the incremental improvements in Alternative 1. The effectiveness of this alternative is primarily due to diverting flows away from the Binney Street sewer to the Massachusetts Avenue drainage system. The added flows however, will cause the Massachusetts Avenue drain to operate near its maximum conveyance capacity and potentially limit additional flows from the Massachusetts Avenue drainage area in the future.

Table 4 – Summary of total flood volumes within The Port for Alternative 1 under 10-year 24-hour design storm by 2070

Parameter	2070 10-yr under the 2015 system conditions	2070 10-yr under the 2020 system conditions <sup>1</sup>	2070 10-yr under Alternative 1 <sup>2</sup>
Flood Volume (MG) (% volume reduction)	5.6	4.7 (16%)	1.8 (62%)
% Port Area Flooded	18%	15%	12%
% Port Properties Flooded	40%	29%	25%

<sup>1</sup>Percent reduction compared to existing (2015) system conditions

<sup>2</sup>Percent reduction compared to revised (2020) system conditions

### 2.1.2 Alternative 2 – Hampshire Street catchment separation

This alternative consists of separating the Hampshire Street stormwater catchment area. Figure 10 shows an overview of the gray infrastructure modifications for Alternative 2. This alternative includes three major modifications:

1. Broadway drain is upsized to 72-inch between Broad Canal outfall and Hampshire St catchment  
Sewer separation of the Hampshire Street catchment
2. Broadway drain extended from Ames St to the intersection of Portland St and Hampshire St
3. Overflow structure over the combined sewer at The Portland Street intersection

The Broadway drain upsizing analysis indicates that the 54-inch drainage pipe that connects the Broad Canal outfall and Ames Street on Broadway has the hydraulic capacity to accommodate a larger 72-inch pipe. After the sewer separation, the Hampshire Street catchment will contribute a significant volume of stormwater flow to the drainage system. Hence upsizing the Broadway drain to 72-inch is a prerequisite for this alternative to be viable.



Figure 10 – Alternative 2 overview map

Figure 11 shows a comparison of flood depths and extent between Alternative 2 (blue layer) and the 2020 system conditions (red layer) for the 10-year 24-hour design storm by 2070. The uncovered red areas in this figure represent those that are likely to experience no flooding under Alternative 2 compared to the 2020 system conditions. Model results show that Alternative 2 is effective in reducing flood impacts within The Port. Additionally, because of the location of the Hampshire Street catchment area, results also show flood reduction benefits along segments of Cambridge Street, and reduced flood depths on Hampshire Street.



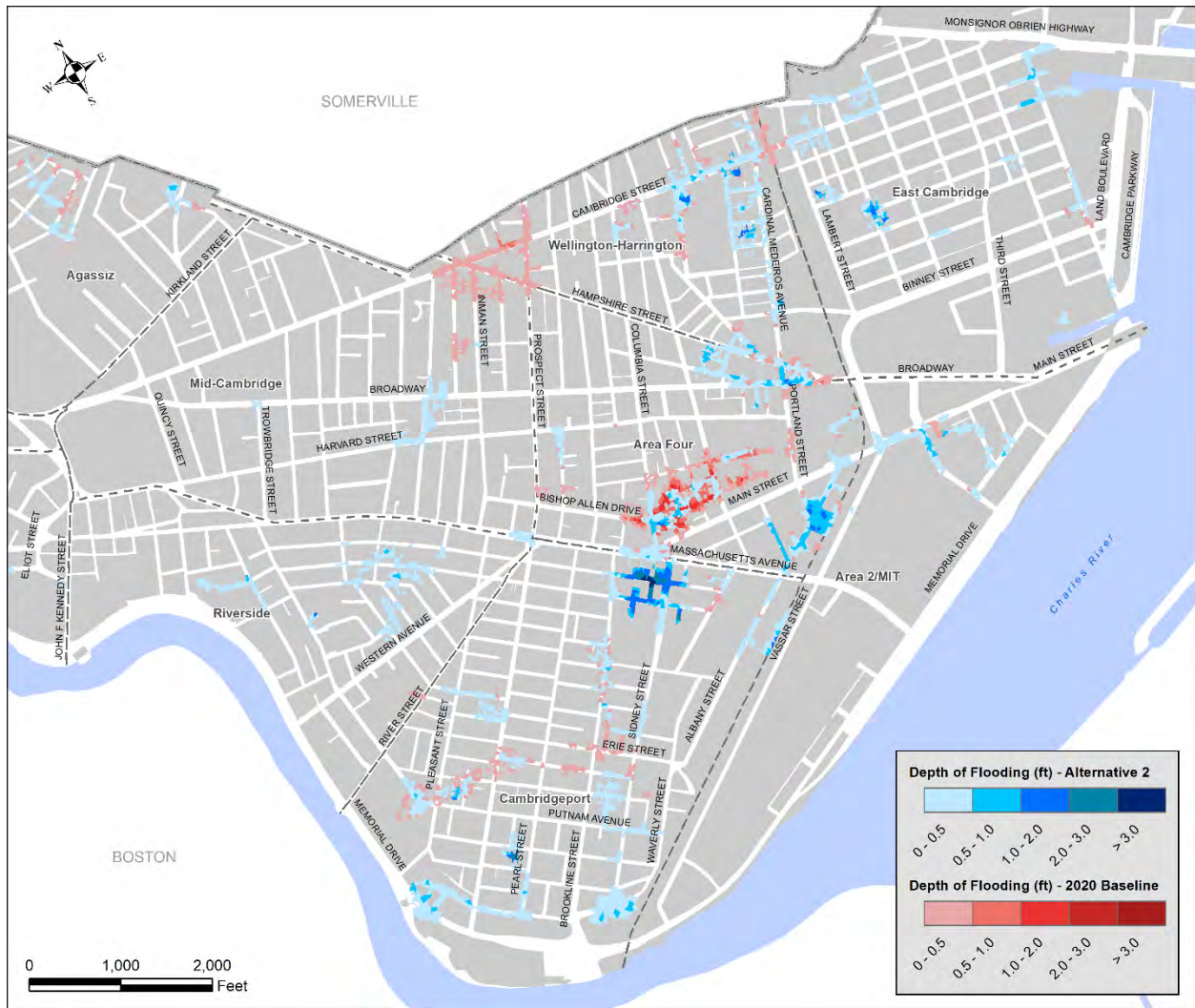


Figure 11 – Flood reduction benefits from Alternative 2 (red = areas that no longer flood) under a 2070 10-year 24-hour storm

Figure 12 presents the same comparison with the top and bottom layers in the reversed order. The uncovered areas in blue color show locations where the model identified new flood areas because of implementing Alternative 2. Like Alternative 1, the inclusion of the Morgan Park stormwater tank caused a hydraulic restriction on the Northern part of Portland Street. Therefore, model results show similar newly flooded areas as Alternative 1, but the overall flood reduction benefits still outweigh the tradeoffs as seen in the comparison maps above.

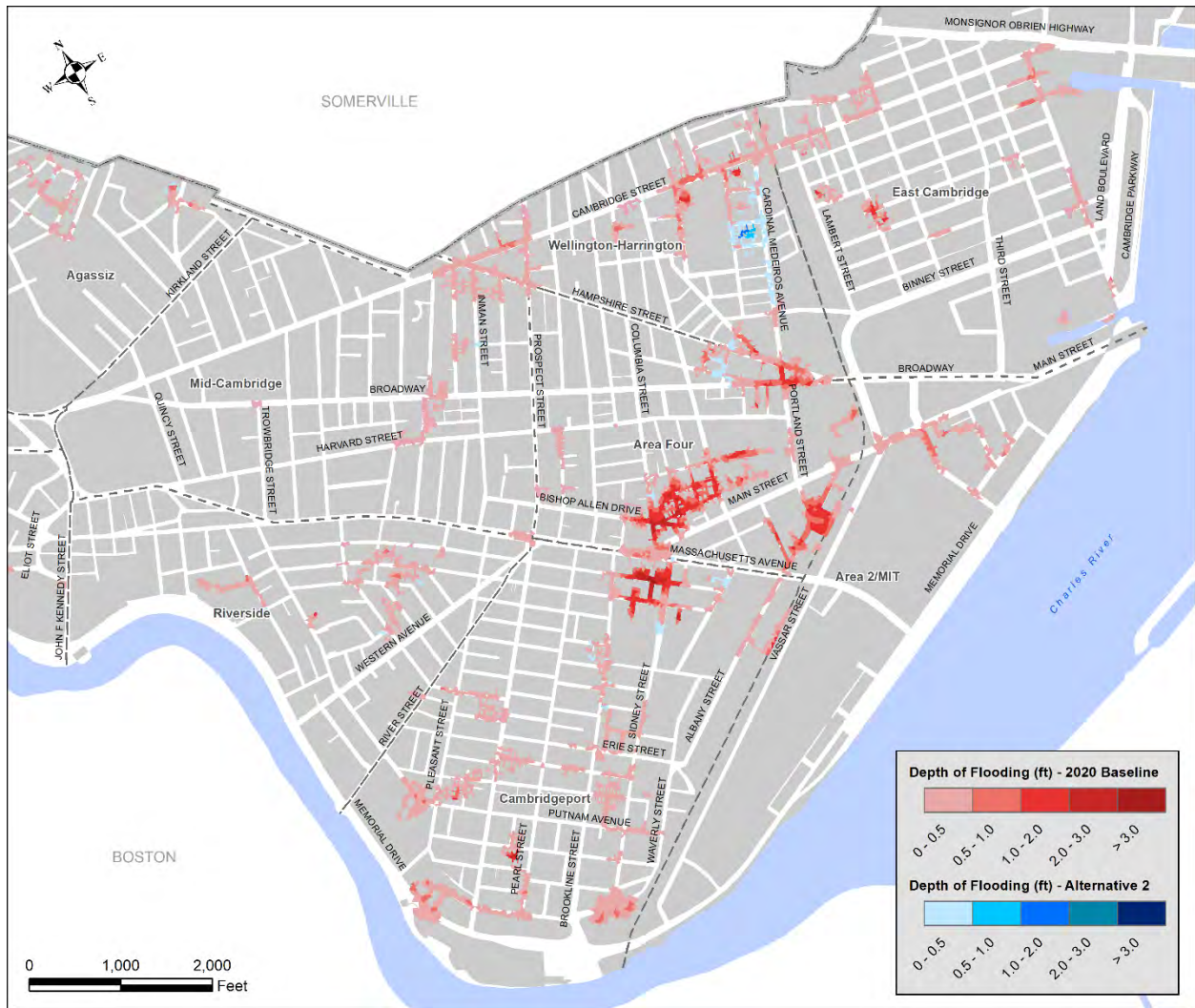


Figure 12 – Flood tradeoffs from Alternative 2 (blue = newly flooded areas) under a 2070 10-year 24-hour storm

Table 5 compares the flood volumes *only within The Port area*. **Alternative 2** is expected to provide a flood reduction of approximately 3.3 MG, a **71% flood volume reduction** under the 10-year 24-hour storm by 2070. Of the total 3.3 MG of flood reduction, 2.6 MG flood reduction can be attributed to the Morgan Park stormwater tank. Therefore, approximately 0.7 MG of flood reduction can be attributed to the incremental improvements in Alternative 2. A significant amount of stormwater runoff is diverted away from the CAM017 drainage system to the Broad Canal system. Diversion of stormwater flows from the Hampshire Street catchment area away from The Port provides significant flood relief to The Port.



Table 5 – Summary of total flood volumes within The Port for Alternative 2 under 10-year 24-hour design storm by 2070

Parameter	2070 10-yr under the 2015 system conditions	2070 10-yr under the 2020 system conditions <sup>1</sup>	2070 10-yr under Alternative 2 <sup>2</sup>
Flood Volume (MG) (% volume reduction)	5.6	4.7 (16%)	1.4 (71%)
% Port Area Flooded	18%	15%	8%
% Port Properties Flooded	40%	29%	17%

<sup>1</sup>Percent reduction compared to existing (2015) system conditions

<sup>2</sup>Percent reduction compared to revised (2020) system conditions

### 2.1.3 Alternative 3 – Lechmere system diversion

This alternative consists of redirecting stormwater from areas north of Binney Street, east of Fulkerson Street, and along Cambridge Street (between Sciarappa and Eighth Street). Flows would be redirected towards the adjacent Lechmere Canal stormwater system. Figure 13 shows an overview of the gray infrastructure modifications for Alternative 3. Alternative 3 was referenced in the 2016 East Cambridge and Cambridgeport Infiltration/Inflow Gray Infrastructure Mitigation Alternatives report. In this alternative existing stormwater flows from The Port will continue to discharge into the Binney Street combined sewer.



Figure 13 – Alternative 3 overview map

Flows between Sciarappa St and 8<sup>th</sup> street on Cambridge streets, along with tributary areas to the Roger St drainage pipe will be diverted to the Lechmere Canal drainage system. Due to the added flows and limited conveyance capacity of the Lechmere system, a stormwater tank at Ahern park is necessary to attenuate upstream flows to prevent flooding areas near the Lechmere canal outfall.

The concept of this alternative is to alleviate stormwater contributions to the Binney street combined sewer by diverting part of its original flows along Rogers St to the Lechmere system. In other words, the restored capacity implies added conveyance capacity for upstream flows from The Port, hence improving flood impacts in the area.

Figure 14 shows a comparison of flood depths and extent between Alternative 3 (blue layer) and the 2020 system conditions (red layer) for the 10-year 24-hour design storm by 2070. The uncovered red areas in this figure represent those that are likely to experience no flooding under Alternative 3 compared to the 2020 system conditions. Model results show that the diverted flows to the Lechmere System do not benefit The Port area significantly. The flood reduction benefits we see from the comparison map above are mainly due to the Morgan Park stormwater tank that is included in all the alternatives.

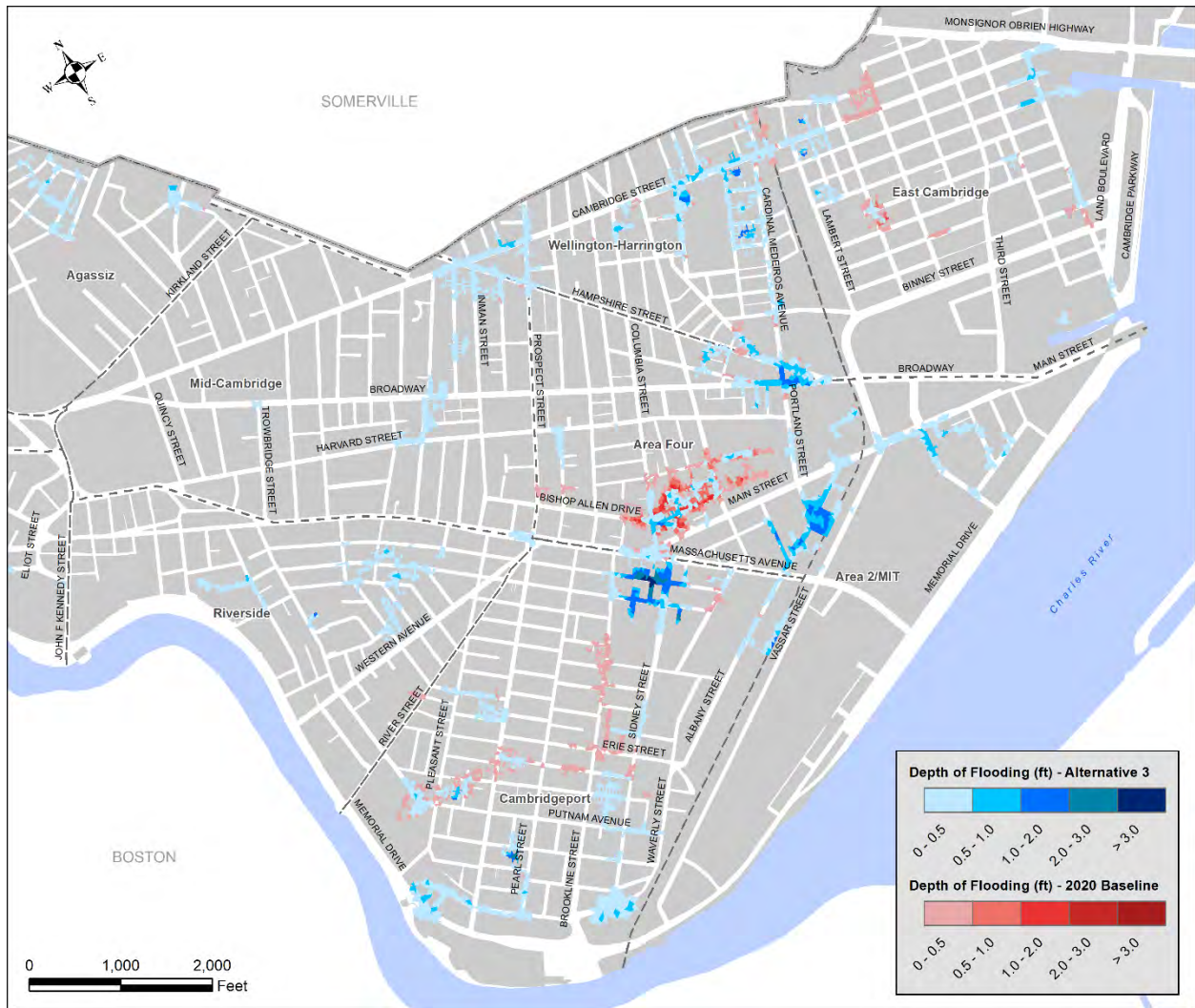


Figure 14 – Flood reduction benefits from Alternative 3 (red = areas that no longer flood) under a 2070 10-year 24-hour storm

Figure 15 presents the same comparison with the top and bottom layers in the reversed order. The uncovered areas in blue color show locations where the model identified new flood areas because of implementing Alternative 3. Some newly flooded area near the Project 9ab site are identified here, for the same reasons as Alternatives 1 and 2. It is also important to note that the diversion of stormwater flows to the Lechmere System did not cause any negative impacts in the Lechmere area, as the results do not show any newly flooded areas.



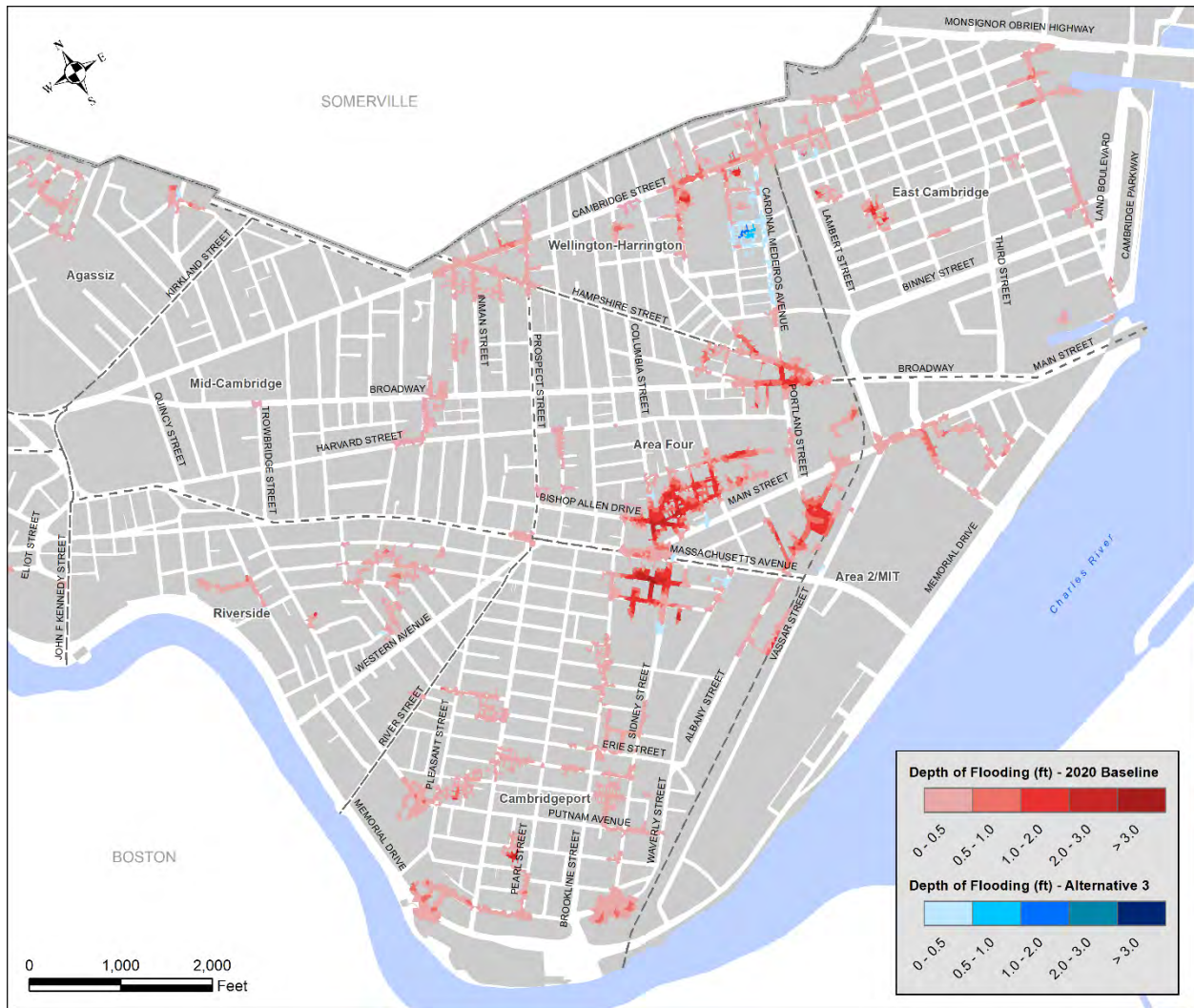


Figure 15 – Flood tradeoffs from Alternative 3 (blue = newly flooded areas) under a 2070 10-year 24-hour storm

Table 6 compares the flood volumes only within *The Port area*. **Alternative 3** is expected to provide flood reduction of approximately 2.8 MG, a **60% flood volume reduction** under the 10-year 24-hour storm by 2070. Of the total 2.8 MG of flood reduction, 2.6 MG flood reduction can be attributed to the Morgan Park stormwater tank. Therefore, approximately 0.2 MG of flood reduction can be attributed to the incremental improvements in Alternative 3.

Table 6 – Summary of total flood volumes within The Port for Alternative 3 under 10-year 24-hour design storm by 2070

Parameter	2070 10-yr under the 2015 system conditions	2070 10-yr under the 2020 system conditions <sup>1</sup>	2070 10-yr under Alternative 3 <sup>2</sup>
Flood Volume (MG) (% volume reduction)	5.6	4.7 (16%)	1.9 (60%)
% Port Area Flooded	18%	15%	10%
% Port Properties Flooded	40%	29%	19%

<sup>1</sup>Percent reduction compared to existing (2015) system conditions

<sup>2</sup>Percent reduction compared to revised (2020) system conditions

### 2.1.4 Alternative 4 – Hampshire Street catchment separation with Donnelly Field tank

This alternative is similar to Alternative 2 but includes a stormwater storage system at Donnelly Field northeast of the Hampshire St catchment. The storage system is assumed to be fed via two overflows, inlet weirs. Figure 16 shows an overview of the gray infrastructure modifications for Alternative 4.



Figure 16 – Alternative 4 overview map

The first overflow weir is designed to capture excess flows from the Hampshire Street drain and convey them to the storage system via a conduit along Webster Avenue. The second overflow weir is designed to capture excess flows from Project 9ab and convey them to the storage system via a new drain along Hardwick Street. High level overflows are modeled from the Hampshire St catchment (west of Portland St) and the Broadway drain extension (east of Portland St). Flows west of Portland St must reach a sufficient hydraulic grade before releasing to the east of Portland St.



Figure 17 shows a comparison of flood depths and extent between Alternative 4 (blue layer) and the 2020 system conditions (red layer) for the 10-year 24-hour design storm by 2070. The uncovered red areas in this figure represent those that are likely to experience no flooding under Alternative 4 compared to the 2020 system conditions. The most distinct flood reduction benefit from this alternative compared to the other alternatives is at the intersection of Broadway and Portland Street. The Donnelly Field stormwater tank can capture some of the surface flood volume at that intersection via the overflow connection on Webster Avenue.

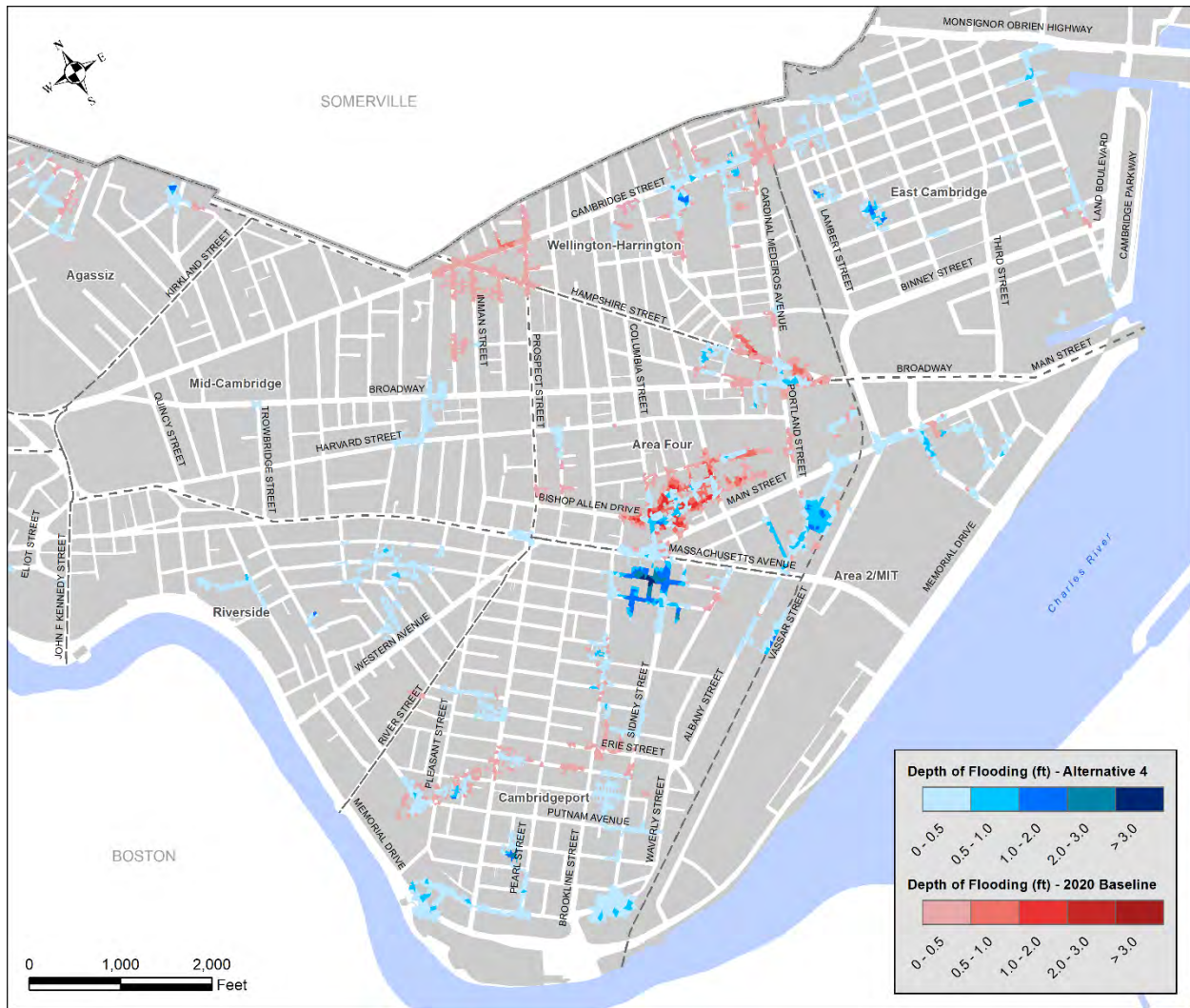


Figure 17 – Flood reduction benefits from Alternative 4 (red = areas that no longer flood) under a 2070 10-year 24-hour storm

Figure 18 presents the same comparison with the top and bottom layers in the reversed order. The uncovered areas in blue color show locations where the model identified new flood areas because of implementing Alternative 4. However, in Alternative 4, no new areas are flooded. This can be attributed to the effectiveness of the Donnelly Field stormwater tank as it is strategically located to alleviate flooding at the Hampshire St/Portland St intersection, as well as Project 9ab drain.

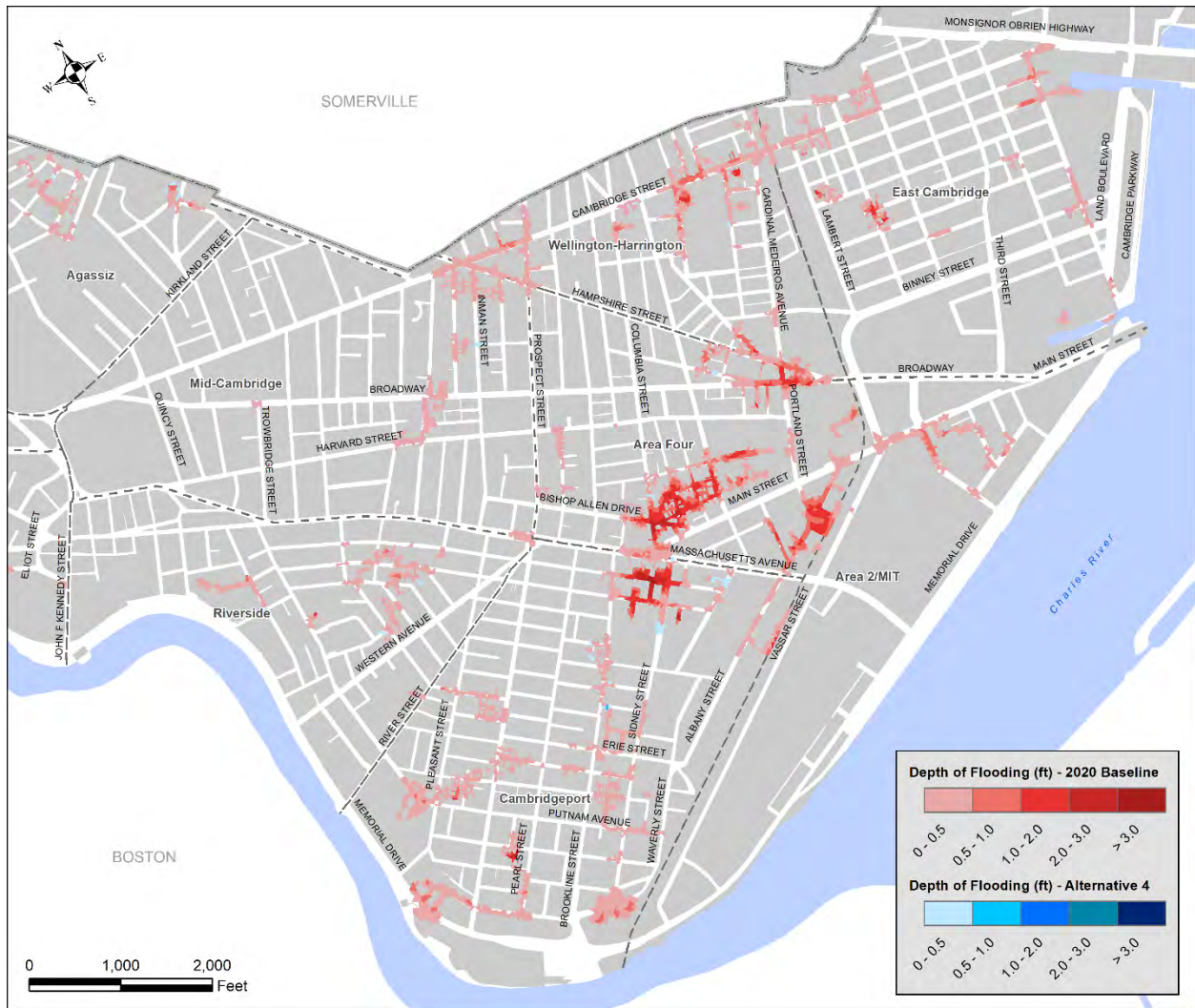


Figure 18 – Flood tradeoffs from Alternative 4 (blue = newly flooded areas) under a 2070 10-year 24-hour storm

Table 7 compares the flood volumes only within *The Port area*. **Alternative 4** is expected to provide a flood reduction of approximately 3.5 MG, a **74% flood volume reduction** under the 10-year 24-hour storm by 2070. Of the total 3.5 MG of flood reduction, 2.6 MG flood reduction can be attributed to the Morgan Park stormwater tank. Therefore, approximately 0.9 MG of flood reduction can be attributed to the incremental improvements in Alternative 4. Under this alternative, a significant amount of stormwater runoff volume is diverted away from the CAM017 drainage system and into the Broad Canal system instead, thereby restoring conveyance capacity for pipes in the Port Area.



Table 7 – Summary of total flood volumes within The Port for Alternative 4 under 10-year 24-hour design storm by 2070

Parameter	2070 10-yr under 2015 system conditions	2070 10-yr under 2020 system conditions <sup>1</sup>	2070 10-yr under Alternative 4 <sup>2</sup>
Flood Volume (MG) (% volume reduction)	5.6	4.7 (16%)	1.2 (74%)
% Port Area Flooded	18%	15%	8%
% Port Properties Flooded	40%	29%	16%

<sup>1</sup>Percent reduction compared to existing (2015) system conditions

<sup>2</sup>Percent reduction compared to revised (2020) system conditions

### 2.1.5 Alternative 5 – Gold Star Mothers Park stormwater facility

This alternative consists of capturing stormwater runoff from the Twin City Plaza parking lot and roofs and directing it to a storage system located in the adjacent Gold Star Mothers Park. Stormwater would then be pumped to the proposed Monsignor O’Brien Highway storm drain after the storm has passed. Figure 19 shows an overview of the gray infrastructure modifications for Alternative 5. The Twin City Plaza area (highlighted in Green) is a large outdoor shopping area with very high imperviousness that contributes a significant amount of stormwater runoff to the Cambridge Branch sewer north of The Port. Therefore, addition of the stormwater tank and pump station can restore conveyance capacity limitations downstream in The Port.



Figure 19 – Alternative 5 overview map



Figure 20 shows a comparison of flood depths and extent between Alternative 5 (blue layer) and the 2020 system conditions (red layer) for the 10-year 24-hour design storm by 2070. The uncovered red areas in this figure represent those that are likely to experience no flooding under Alternative 5 compared to the 2020 system conditions. However, the flood reduction benefits in The Port shown in Figure 20 can primarily be attributed to the Morgan Park stormwater tank that is included in all the alternatives.

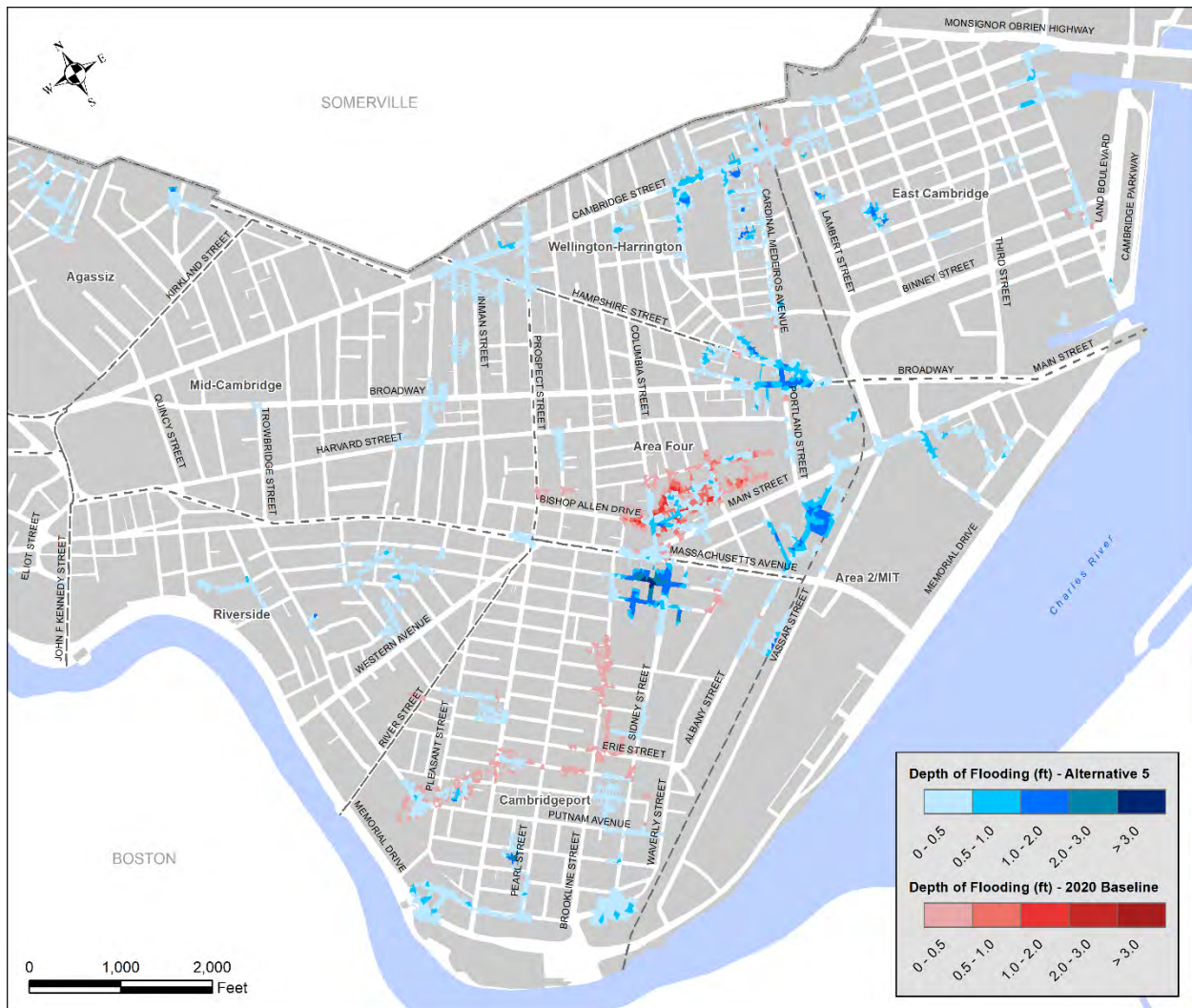


Figure 20 – Flood reduction benefits from Alternative 5 (red = areas that no longer flood) under a 2070 10-year 24-hour storm

Figure 21 presents the same comparison with the top and bottom layers in the reversed order. The uncovered areas in blue color show locations where the model identified new flood area under Alternative 5. The same newly flooded areas near the Project 9ab site are identified here, for likely the same reasons as in Alternatives 1 through 3. It is likely that a connection between the project 9ab area and the Gold Star Mothers Park stormwater tank can potentially alleviate flood problems around this area.

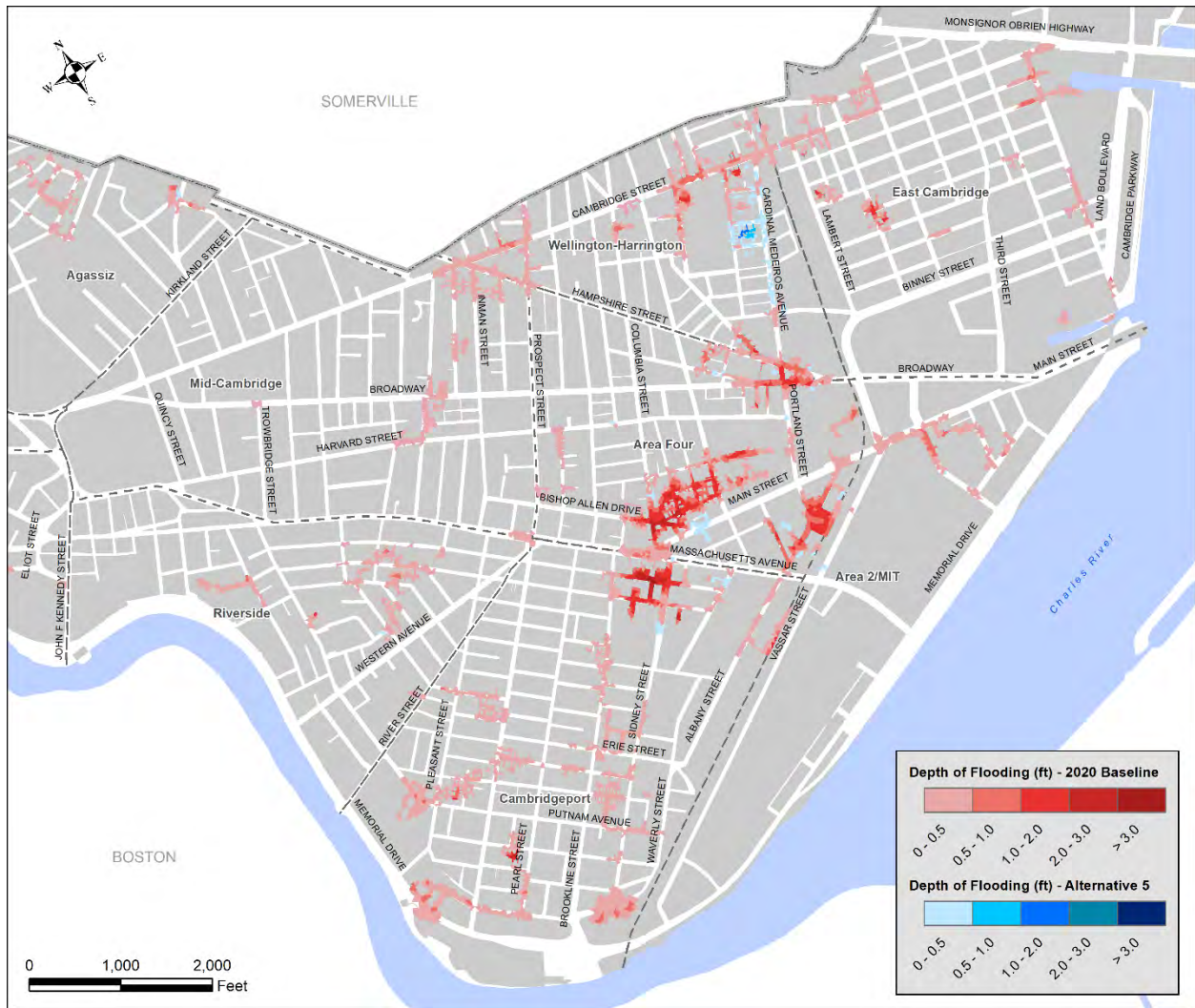


Figure 21 – Flood tradeoffs from Alternative 5 (blue = newly flooded areas) under a 2070 10-year 24-hour storm

Table 8 compares the flood volumes *only within The Port area*. **Alternative 5** is expected to provide a flood reduction of approximately 2.7 MG, a **57% flood volume reduction** under the 10-year 24-Hour storm by 2070. Of the total 2.7 MG of flood reduction, 2.6 MG flood reduction can be attributed to the Morgan Park stormwater tank. Therefore, approximately only 0.1 MG of flood reduction can be attributed to the incremental improvements in Alternative 5.



Table 8 – Summary of total flood volumes within The Port for Alternative 5 under 10-year 24-hour design storm by 2070

Parameter	2070 10-yr under 2015 system conditions	2070 10-yr under 2020 system conditions <sup>1</sup>	2070 10-yr under Alternative 5 <sup>2</sup>
Flood Volume (MG) (% volume reduction)	5.6	4.7 (16%)	2.0 (57%)
% Port Area Flooded	18%	15%	11%
% Port Properties Flooded	40%	29%	21%

<sup>1</sup>Percent reduction compared to existing (2015) system conditions

<sup>2</sup>Percent reduction compared to revised (2020) system conditions

### 2.1.6 Alternative 6 – Addition of Albany Street diversion to Alternative 1

This alternative is similar to Alternative 1, but also includes removal of two common manholes on the south side of Main Street between Portland and Albany streets and bulkhead storm drain in Portland Street; removal of illicit connections to the drain along Main Street between Portland and Ames Street; and building a new 36-inch drain along Albany Street connecting the existing Main Street drain on its upstream side to the South Mass Ave drain on the downstream side. Figure 22 shows an overview of the gray infrastructure modifications for Alternative 6.



Figure 22 – Alternative 6 overview map

This alternative was evaluated to address the flooding in the Albany St area, which did not receive any significant flood reduction benefits in Alternatives 1 through 5. The 36-inch drain pipe was considered due to the following reasons:

1. Existing combined sewer on Albany St needs to be repurposed, which favors the constructability of building a new 36-inch drain line on the same street.
2. Testing the sensitivity on the performance of the Mass Av Drain when routing additional flows.
3. Based on preliminary results, Alternative 1 seems to be the most efficient alternative, balancing constructability and overall flood reduction benefits. Therefore, it seems most logical to evaluate the effects of building a new drain line on Albany Street under this alternative.

Figure 23 shows a comparison of flood depths and extent between Alternative 6 (blue layer) and the 2020 system conditions (red layer) for the 10-year 24-hour design storm by 2070. At the location of the N10 Annex MIT parking lot (circled in red in Figure 23), flood impacts have significantly reduced on Albany Street compared to the other alternatives, with flooding mostly limited to nuisance flooding under this alternative.

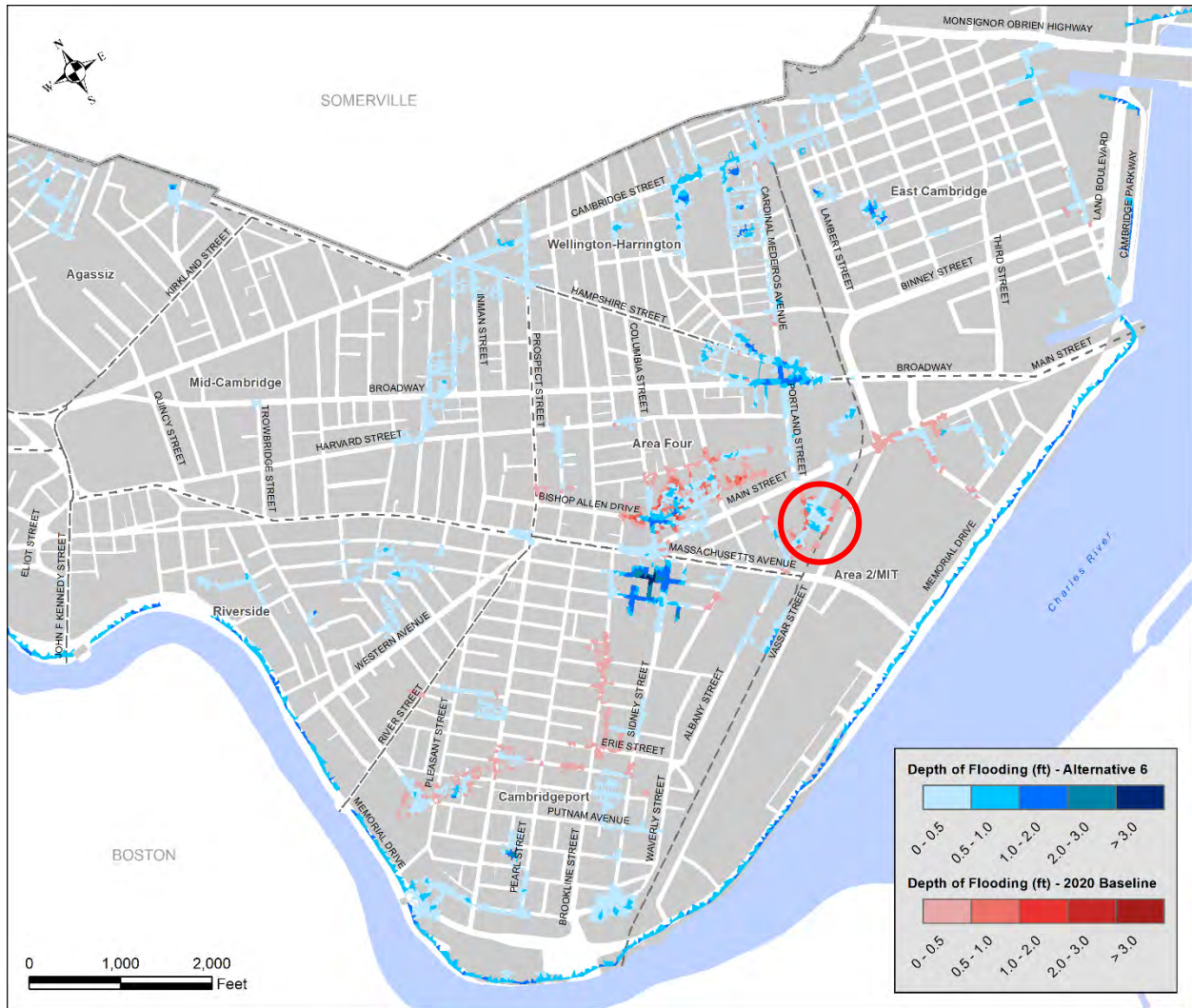


Figure 23 – Flood reduction benefits from Alternative 6 (red = areas that no longer flood) under a 2070 10-year 24-hour storm



Figure 24 presents the same comparison with the top and bottom layers in the reversed order. The uncovered blue color areas are new areas that are likely to be flooded under Alternative 6. Other than the new flooding near Project 9ab, which is likely from the hydraulic restriction caused by the Morgan Park stormwater tank, no additional areas will be flooded. This comparison also confirmed that additional flows from the Albany Street area to the Massachusetts Ave drainage system did not overwhelm that system.

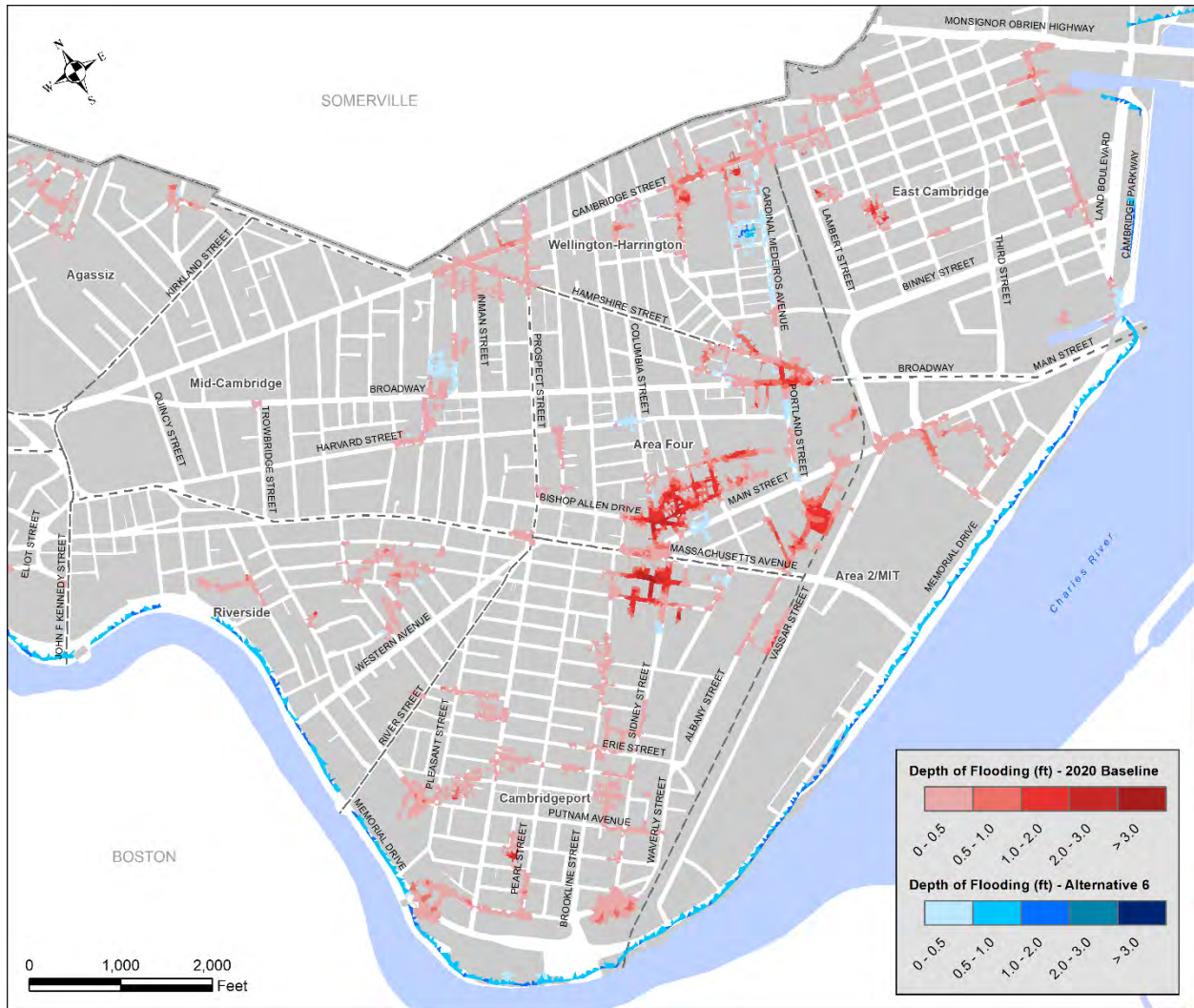


Figure 24 – Flood tradeoffs from Alternative 6 (blue = newly flooded areas) under a 2070 10-year 24-hour storm

Table 9 compares the flood volumes *only within The Port area*. **Alternative 6** is expected to provide flood reduction of approximately 3.1 MG, a **67% flood volume reduction** under the 10-year 24-Hour storm by 2070. Of the total 3.1 MG of flood reduction, 2.6 MG flood reduction can be attributed to the Morgan Park stormwater tank. Therefore, approximately 0.5 MG of flood reduction can be attributed to the incremental improvements in Alternative 6. The effectiveness of this alternative is primarily due to diverting flows away from the Binney Street sewer to the Massachusetts Avenue drainage system.

Table 9 – Summary of total flood volumes within The Port for Alternative 6 under 10-year 24-hour design storm by 2070

Parameter	2070 10-yr under 2015 system conditions	2070 10-yr under 2020 system conditions <sup>1</sup>	2070 10-yr under Alternative 6 <sup>2</sup>
Flood Volume (MG) (% volume reduction)	5.6	4.7 (16%)	1.6 (67%)
% Port Area Flooded	18%	15%	11%
% Port Properties Flooded	40%	29%	25%

<sup>1</sup>Percent reduction compared to existing (2015) system conditions

<sup>2</sup>Percent reduction compared to revised (2020) system conditions

## 2.2 Gray infrastructure alternatives key findings

Six gray infrastructure alternatives were evaluated for The Port and the respective flood volumes for each alternative for the 10-year 24-hour design storm by 2070 are summarized in Table 10. For all these alternatives, the stormwater tank at Morgan Park with a storage capacity of 0.78 MG and a pumping capacity of 10 MGD is assumed to be implemented, which is estimated to reduce flooding in The Port by 2.6 MG. The incremental flood reduction benefits that gray infrastructure Alternatives 1 through 6 provide over the benefit from the Morgan Park stormwater tank vary from 0.1 MG (Alternative 5) to 0.9 MG (Alternative 4) for the 10-year 24-hour design storm by 2070. Alternative 4 which includes separating the Hampshire Street stormwater catchment area and installing a stormwater storage tank at Donnelly Field is the best performing alternative in terms of flood reduction. However, conducting sewer separation for a large area such as the Hampshire Street catchment requires significant resources and is likely to cause significant neighborhood impacts, making Alternative 4 less favorable. On the other hand, Alternative 6 includes diverting stormwater flows from The Port south towards the stormwater outfall on Massachusetts Avenue, adding a new 36-inch drain line on Albany Street and repurposing mostly existing/abandoned infrastructure, which makes this alternative economically more favorable and less disruptive to the neighborhood. Hence for this study, Alternative 6 was selected as the most favorable gray infrastructure alternative. The total flood reduction benefit from this alternative is 3.1 MG, of which 2.6 MG reduction is estimated from the Morgan Park stormwater tank and the remaining 0.5 MG reduction is the incremental flood reduction benefit from this alternative. Alternative 6 is the selected alternative that will be combined with green infrastructure and also to study the effects of short duration storms under these proposed conditions.

Table 10 – Summary of total flood volumes for all gray infrastructure alternatives under the 10-year 24-hour storm by 2070

	2020 system conditions	2020 system conditions + Morgan Tank	Alternative 1	Alternative 2	Alternative 3	Alternative 4	Alternative 5	Alternative 6
Flood Volume (MG)	4.7	2.1	1.8	1.4	1.9	1.2	2.0	1.6

### 3 Green infrastructure

With drainage infrastructure improvement projects that are to be completed by 2020, The Port neighborhood is likely to still experience 4.7 MG for the 10-year 24-hour design storm by 2070. The selected best gray infrastructure Alternative 6 can reduce the flooding to 1.6 MG for the same storm scenario. However, the City agreed that **flood mitigation strategies in The Port at a minimum need to be able reduce the flooding from the 10-year storm by 2070 (4.7 MG), such that it is not any worse than the flooding from the present 10-year storm (1.2 MG)**. Therefore, the City decided to explore green infrastructure opportunities in addition to the selected gray infrastructure alternative, such that flooding in The Port is less than 1.2 MG for the 10-year storm by 2070.

Different green Infrastructure strategies were researched for The Port in terms of their effectiveness and applicability. Green infrastructure has been widely implemented in the Northeast states, such as Hoboken, NJ and Onondaga County, NY, and Philadelphia, PA to name a few. Green infrastructure can reduce flooding by infiltrating stormwater into native soil and recharge groundwater, restore surface perviousness, reduce urban heat island effect, improve water quality and increase overall aesthetics of a neighborhood.

#### 3.1 Types of green infrastructure considered

Five types of green infrastructure are considered for The Port area, summarized in

Table 11, each of which is described in more details in the following sections:

*Table 11 – Types of green infrastructure considered and targeted application for The Port*

Type of Green Infrastructure	Application
<b>Rain Garden</b>	Medium-Density Residential parcels
<b>Porous Pavement</b>	Public/Private parking lots, open space walkways
<b>Leaching Catch Basins</b>	Existing catch basins
<b>Tree Box Filters</b>	Sidewalks. Option to connect nearby leaching catch basins
<b>Blue / Green Roofs</b>	Commercial Buildings and Public Housing



### 3.1.1 Rain gardens

Approximately 20% of the parcels within The Port are classified for medium-density residential use. These parcels in The Port shows a balanced mix of roof area and pervious area (e.g. front and back yard). Rain gardens utilize this characteristic to capture roof runoffs and infiltrate the runoffs into native soils.

To select suitable parcels and estimate the potential captured flood volume of the rain gardens, a high-level design assumes the following technical requirements and specifications:

- Minimum of 300 square feet pervious area available within the parcel
- Minimum 10' separation from building footprint to avoid basement seepage
- 0.5' maximum ponding depth
- 2' engineering soil
- 20% porosity within the structure to estimate static storage volume

Figure 25 shows in blue the potential locations that satisfy the above criteria to implement rain gardens. From a GIS analysis to identify parcels that match the above criteria, approximately 69,800 square feet with private, medium-residential parcels are suitable to implement rain garden. Based on the assumptions above, the static treated stormwater volume is estimated to be:

$$= 69,800 \text{ SF} \times (0.5' + 2' \times 20\%) = 62,820 \text{ cubic feet} \approx \mathbf{0.5 \text{ MG flood volume captured}}$$

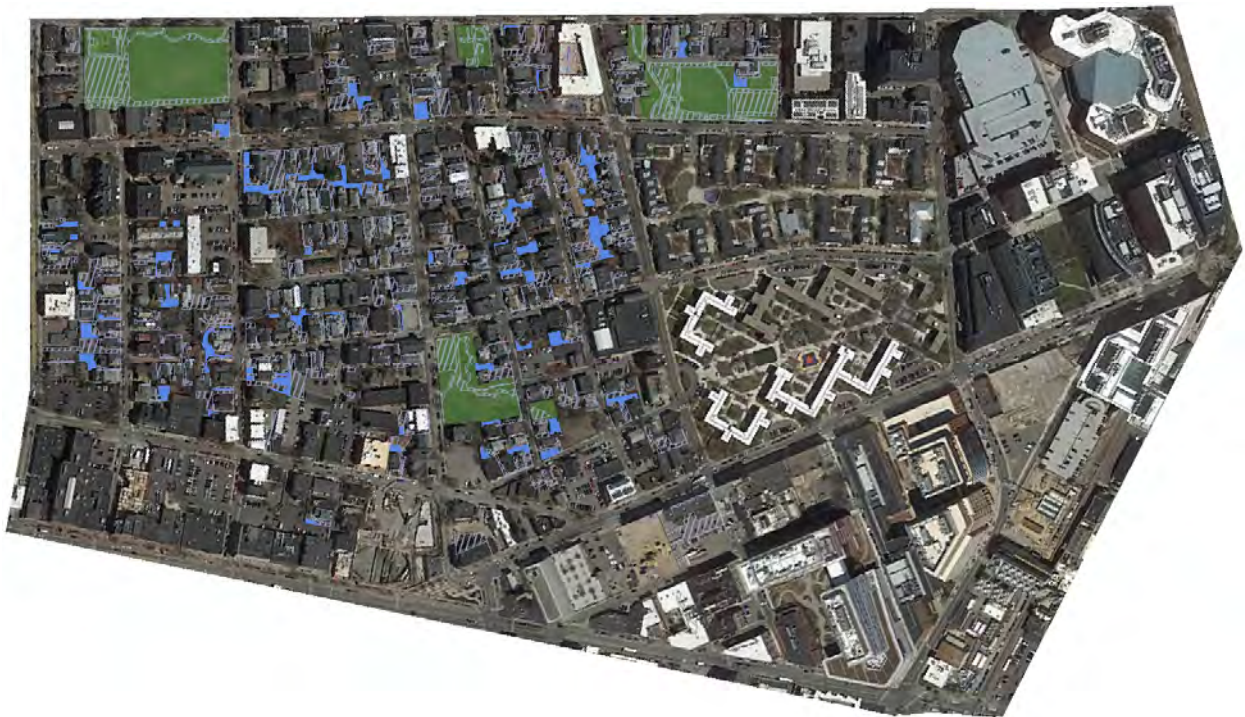


Figure 25 – Potential locations to implement rain gardens

### 3.1.2 Porous pavement

Porous pavement is a stormwater management practice that can effectively decrease the imperviousness of a paved surface. Surface materials can include asphalt, concrete, and/or other types of pavers with an increased porosity. Voids can help store surface runoffs and attenuate flows into the drainage system. The stored runoff volume can also infiltrate into the native soil, providing groundwater recharge.

For The Port, the most suitable locations to implement porous pavement include both private and public parking lots and driveways, as well as walkways in open space areas. To estimate the potential captured flood volume by the porous pavements, the following specifications are assumed:

- Porous material depth of 9"
- 40% porosity throughout the depth of the porous material
- 20% Implementation level, acknowledging implementation challenges

Implementation of porous pavement requires a committed maintenance plan. The 20% implementation level acknowledges the fact that there are challenges in terms of maintenance efforts and potential utility conflicts.

Figure 26 shows the approximated 270,000 square feet of identified pavement surfaces within The Port can be implemented with porous pavement materials. Based on the assumptions above, the treated volume is estimated to be:

$$= 270,000 \text{ SF} \times \left( \frac{9'}{12} \times 40\% \right) \times 20\% = 16,200 \text{ cubic feet} \approx \mathbf{0.12 \text{ MG flood volume captured}}$$

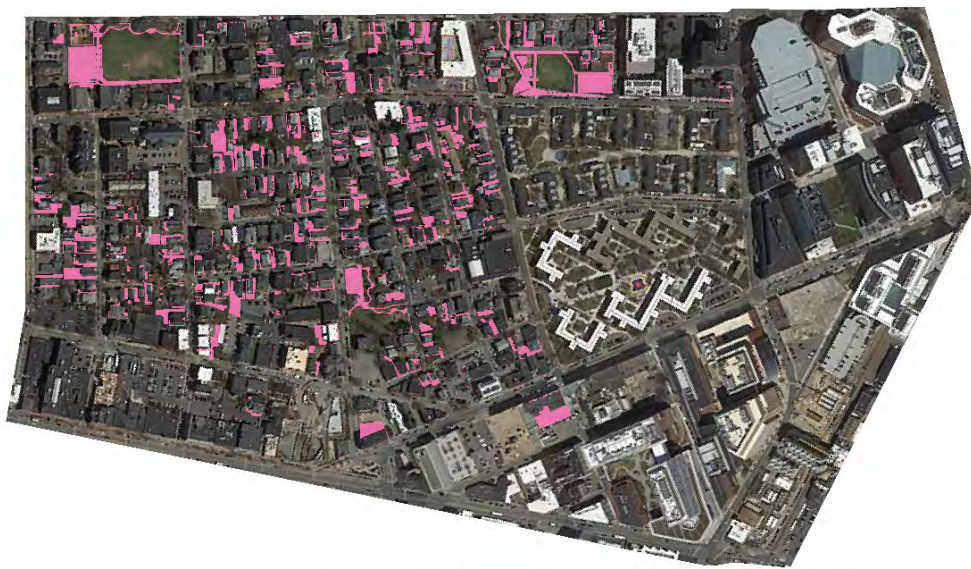


Figure 26 – Impervious pavement surfaces in low/medium-density residential parcels and open spaces



### 3.1.3 Leaching catch basins

Leaching catch basins provide pretreatment and flow attenuation to surface runoffs. This is done by allowing the collected stormwater runoffs to infiltrate through a pervious sidewall, stored in the surrounding stone voids, and ultimately recharge into native soil. Once the static storage volume in the stone voids reach capacity, the collected runoffs overflow into the stormwater drainage system like a traditional catch basin.

In this design specific to The Port area, the leaching catch basins can be constructed to connect nearby tree box filters. Details of this connection are discussed in the next subsection 3.1.4.

Within The Port, there are approximately 460 traditional catch basins, as shown in Figure 27. Based on a leaching catch basin design developed by Stantec for the City of Cambridge<sup>4</sup>, each leaching catch basin has a static storage volume of 91 cubic feet. A standard detail from the Stantec technical memorandum is shown below in Figure 28.

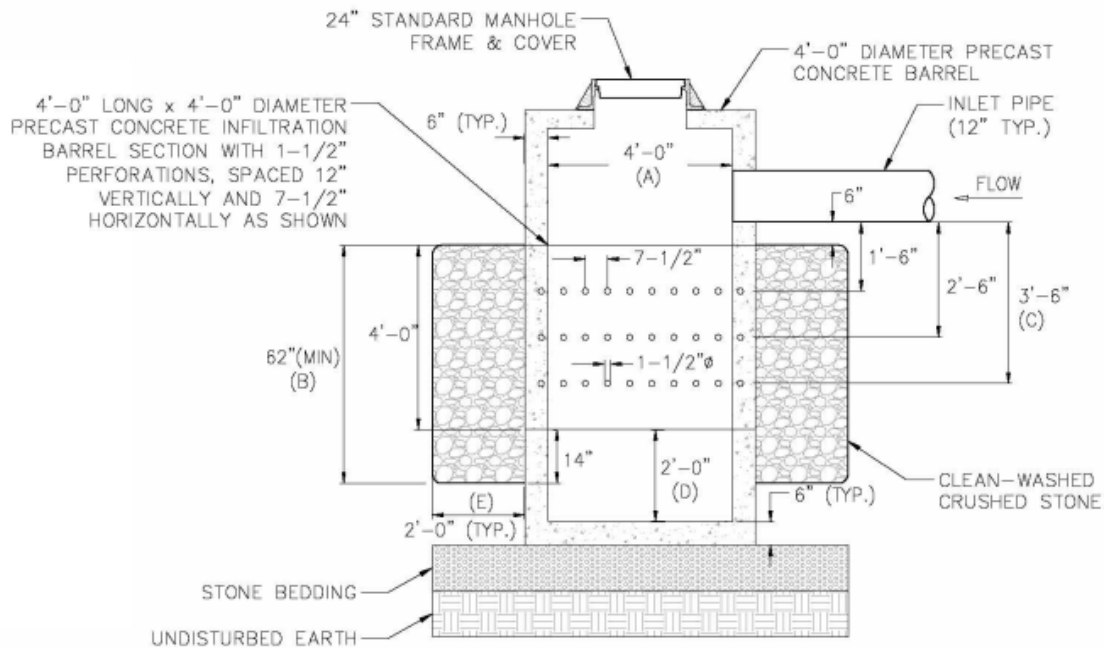
Using a 20% implementation on the 460 catch basins, acknowledging implementation challenges and feasibility of construction, the following calculation estimates the flood volume that can be captured by leaching catch basins within The Port:

$$= 460 \times 91 \times 20\% = 8,372 \text{ cubic feet} \approx \mathbf{0.06 \text{ MG flood volume captured}}$$

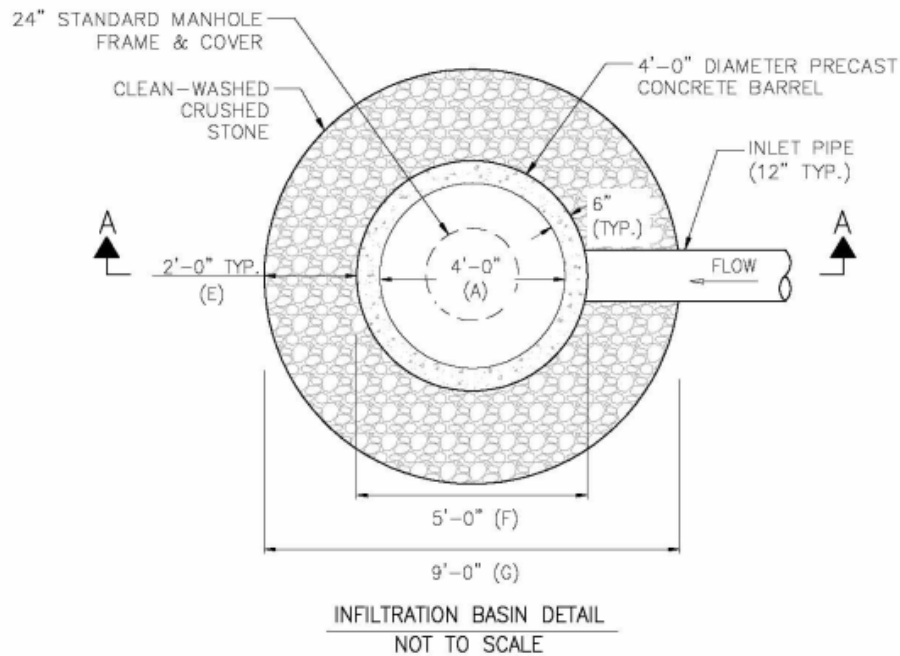


Figure 27 – Existing catch basins in The Port

<sup>4</sup> Refer to technical memo titled “Cambridge Total Phosphorous Analysis – Infiltrating Catchbasin Study” submitted by Stantec to the City of Cambridge on August 15, 2018.



SECTION A-A



INFILTRATION BASIN DETAIL  
NOT TO SCALE

Figure 28 – Leaching catch basin concept design detail<sup>5</sup>

<sup>5</sup> Refer to technical memo titled “Cambridge Total Phosphorous Analysis – Infiltrating Catch Basin Study” submitted by Stantec to the City of Cambridge on August 15, 2018.

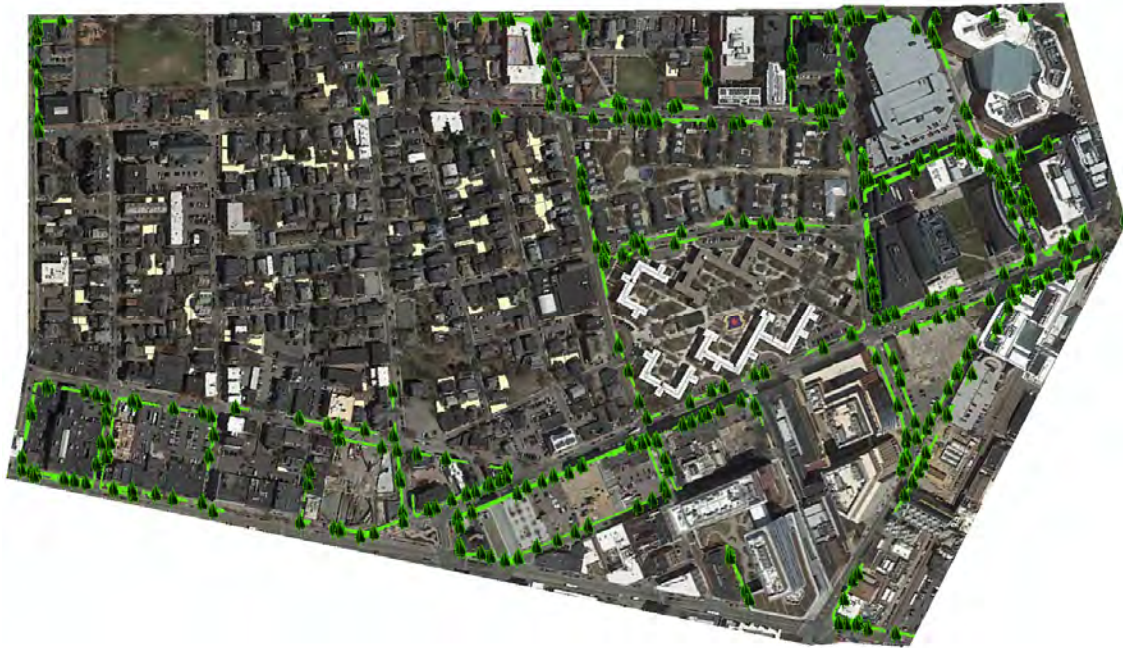


### 3.1.4 Tree box filters

Tree box filters help promote groundwater recharge and provide flow attenuation benefits like rain gardens and bioretention basins. This stormwater management practice can have different specifications and is highly adaptable to dense urban setting like The Port.

For the high-level design tailored for The Port, the tree box filters were proposed to be connected laterally to nearby leaching catch basins. Tree box filters can also be potentially interconnected using perforated drainage pipes, which was assumed for some select locations described in Section 3.2. Figure 29 shows the available sidewalk spaces to plant new trees that satisfy the following criteria:

- Sidewalks greater than 8 feet wide
- Spacing between trees every 30 feet and no trees on driveways



*Figure 29 – Available sidewalks for tree planting*

Connecting the leaching catch basins and the tree box filters not only maximizes the amount of stormwater runoff captured from both sidewalks and roadways, but also helps to promote tree growth that complements the strategies in the City’s Urban Forest Master Plan (UFMP). This type of combined green infrastructure system can provide both flood mitigation and urban heat island reduction benefits.

Figure 30 illustrates the details of how a tree box filter can be connected to a leaching catch basin. This conceptual design detail has been jointly developed through collaboration with the CCPR Team and the UFMP Team. For the tree box filters, specifications are assumed as follows:

- Sidewalks must be wider than 8-feet to accommodate for the tree box filters
- Root zone of the tree box has a dimension of 3'W x 12' L x 3'H
- Infiltrating stone base has a dimension of 7' W x 12' L x 2.5' H
- Within the stone base, a 6" layer of 3/8"-stone has a 20% porosity
- Within the stone base, a 24" layer of 3/4" stone has a 35% porosity

From Section 3.1.3, if we assume 20% of all 460 catch basins are each connected to a tree box filter, the flood volumes that can be captured by tree box filters are estimated at:

$$\begin{aligned}
 &= 460 \times 20\% \times 7' \times 12' \times \left[ \left( \frac{24'}{12} \times 35\% \right) + \left( \frac{6'}{12} \times 20\% \right) \right] \\
 &= 460 \times 20\% \times 84 \text{ SF} \times 0.8 \\
 &= 6,182 \text{ cubic feet} \approx \mathbf{0.05 \text{ MG flood volume captured}}
 \end{aligned}$$

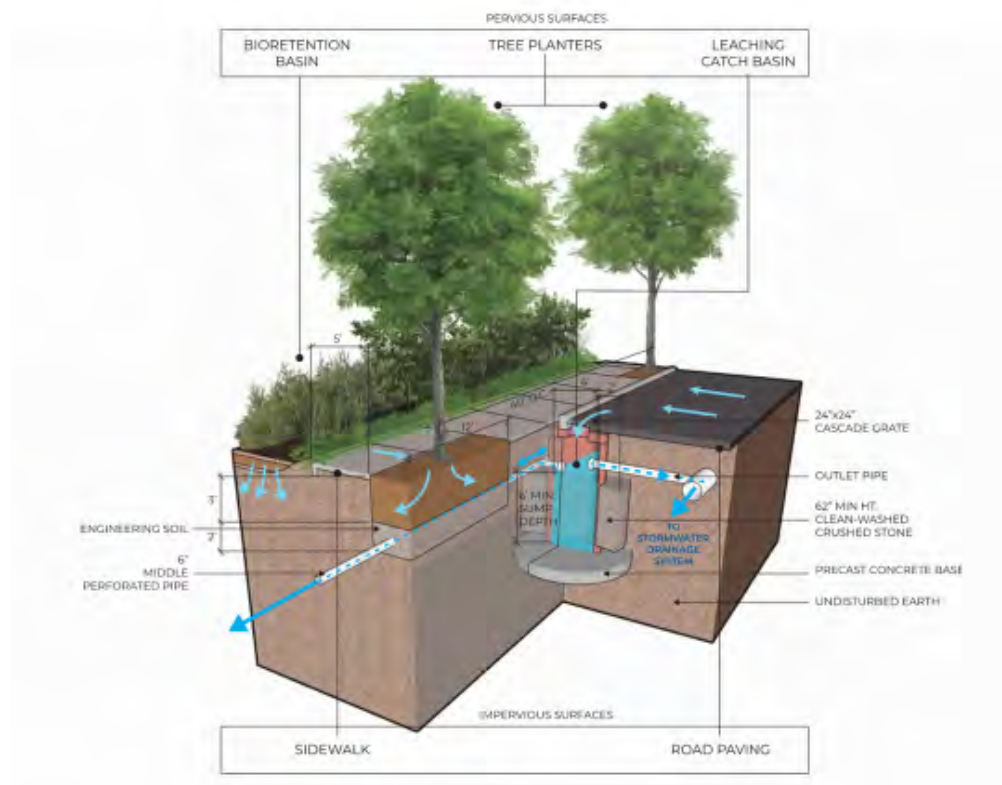


Figure 30 – Conceptual design detail for tree box-leaching catch basin cross-connection

### 3.1.5 Green roofs

In a neighborhood as densely developed as The Port, building roofs contribute a significant amount of stormwater runoff that directly discharge into the drainage system. Direct rainfall on the green roofs allow vegetation to uptake stormwater and transpire into the air. Green roofs also lower ambient temperature in the area and naturally regulates indoor temperature of the buildings, thus reducing energy consumed for heating and cooling.

Flat roofs in The Port have a total footprint at approximately 1,400,000 square feet, as shown in Figure 31. With the following assumptions:

- 30% of flat-roofed buildings implement green roofs with each green roof taking up 70% of the available roof area, which translates to approximately a 21% implementation level.
- Effective vegetation storage depth of 1.6", accounting for voids and plant uptake

The flood volumes that can be captured by green roofs are estimated at:

$$= 1,400,000 \times 21\% \times \left(\frac{1.6'}{12}\right) = 37,300 \text{ cubic feet} \approx \mathbf{0.3 \text{ MG flood volume captured}}$$



Figure 31 – Buildings with flat roofs in The Port



## 3.2 Green infrastructure modeling approach

Since the City decided to explore green infrastructure opportunities in addition to gray infrastructure alternatives, such that flooding in The Port is less than 1.2 MG for the 10-year storm by 2070, the green infrastructure strategies discussed in section 3.1 were modeled in combination with gray infrastructure Alternative 6. Alternative 6 was selected since it strikes the best balance between constructability, social impacts and future development opportunities.

The green infrastructure strategies are modeled in two different setups for distinct areas within The Port, referred as the “hybrid approach”. The hybrid approach assumes:

- Maximum extent practical (MEP) implementation level for two selected “Resilient Blocks”
- For areas within The Port, excluding the two resilient blocks, the implementation level for each type of green infrastructure is described in Section 3.1.

The two selected resilient blocks shown in Figure 32 represent distinct land-use types that characterize The Port with a significant differentiation between land-use types:

1. The first resilient block at the Green-Rose Heritage Park has a mix of open-space, medium to high-density residential parcels and commercial buildings
2. The second resilient block is a typical residential block in The Port with mostly medium-density residential parcels, private parking lots and a community center.

Two resilient blocks were selected as pilot areas to test how these blocks can be replicable elsewhere in the City. These two resilient blocks demonstrate characteristics that are representative of the nature of The Port in terms of land use type, drainage connection, open space coverage and other critical infrastructure. The two selected blocks are shown in Figure 32 and Table 12 also summarize the distribution of the various types of green infrastructure simulated in the stormwater model within the two resilient blocks. Retrofitting to blue roofs in these two blocks was selected for certain buildings as an alternative to green roofs. In contrast to green roofs, blue roofs only provide stormwater attenuation benefits and they do not have any vegetation, hence reduce the structural load on existing buildings. Blue roofs typically include a roof with raised berm on a relatively flat building roof, hence more frequently applied to commercial building roofs. The square footage for each of the strategies in the resilient blocks (as included in Table 12) were determined based on their implementation locations as shown in Figure 32.





Figure 32 – Footprint of green infrastructure and blue roofs modeled in the two resilient blocks and their locations

Table 12 – Types of green infrastructure and their respective targeted implementation as modeled in the two resilient blocks

Resilient Block Type	Tool Box /Action	Targeted Implementation
<b>Residential</b>	Retrofit buildings with green roofs	3 typical flat roof buildings spanning approximately 2,300 square feet
	Implement on-site porous pavement for stormwater	Approximately 18,000 square feet of existing pavement would need to be resurfaced with porous materials
	Implement on-site rain garden for stormwater	Approximately 1,500 square feet of areas within residential yards would be converted to rain gardens, equivalent to about 60 square feet per parcel in this residential block
	Improve urban tree canopy	Maintain existing trees and plant new trees where possible
<b>Mixed Use</b>	Design new buildings with white/blue roofs	3 new building roofs spanning approximately 25,000 square feet <sup>4</sup> with 4.5 inches of stormwater detained
	Design retrofit buildings with white/blue roofs	3 retrofitted building roofs spanning approximately 25,000 square feet <sup>4</sup> with 0.7 inches of stormwater detained
	Design new buildings with green roofs	About 7 medium-sized building roofs spanning approximately 10,200 square feet would need roof modifications
	Implement on-site rain garden for stormwater	Approximately 3,000 square feet of areas within open spaces and residential backyards would be converted to rain gardens
	Implement on-site porous pavement for stormwater	Approximately 28,000 square feet of existing pavement would need to be resurfaced with porous materials
	Install leaching catch basins to capture stormwater runoff from roadways	6 catch basins would need to be retrofitted into leaching catch basins, and install lateral connections to adjacent tree box filters
	Connect leaching catch basins to tree box filters to maximize stormwater runoff capture from both sidewalks and roadways	16 interconnecting tree box filters will be installed, 6 of them will be laterally connected to adjacent leaching catch basins

Outside of the two resilient blocks, traditional BMP modeling technique is used to model the five types of green infrastructure, implemented at a level described in sections 3.1.1 through 3.1.5. Figure 33 shows the spatial distribution of the five types of green infrastructure considered for The Port (outside the resilient blocks), showing their maximum implementation potential. Table 13 summarizes the actual modeled footprint areas with their respective implementation levels that were modeled.

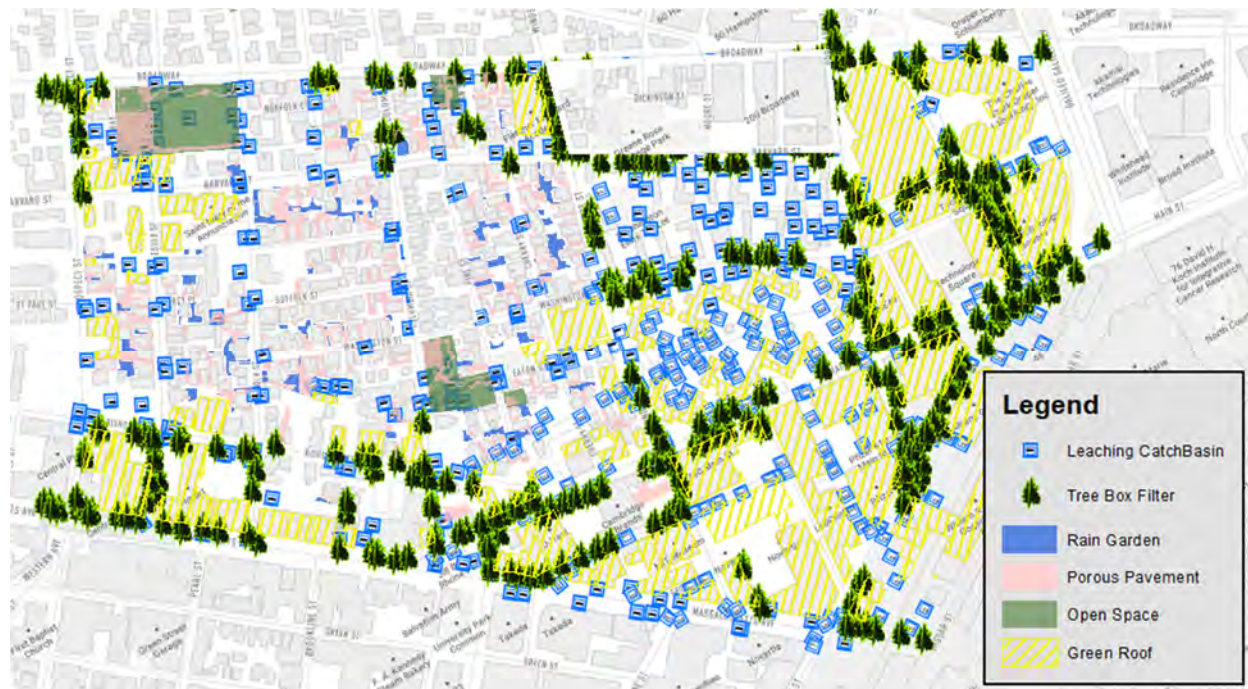


Figure 33 – Types of green infrastructure considered for The Port (outside the resilient blocks), showing their maximum implementation potential

Table 13 – Implementation level and footprint of green infrastructure considered in The Port outside of resilient blocks

TYPE OF GREEN INFRASTRUCTURE	IMPLEMENTATION LEVEL	GREEN INFRASTRUCTURE FOOTPRINT (SQ. FT)
<b>Rain garden</b>	Medium density residential parcels with 300 square feet of pervious lot area and minimum 10' separation from building footprint	69,800
<b>Porous pavement</b>	20% of available 270,000 square feet from private and public parking lots, driveways and walkways in open spaces	54,000
<b>Leaching catch basin</b>	20% of existing 460 catch basins	92
<b>Tree box filter</b>	20% of existing 460 catch basins, each connected to a tree box filter	92
<b>Green roof</b>	70% buildings and 30% roof areas ≈ 21% of 1,400,000 total building roof area	280,000

Further details related to modeling green infrastructure strategies in the resilient blocks and outside of the blocks in The Port are included in Attachment 1 technical memo by Stantec titled “Flood Mitigation Alternatives for The Port neighborhood”.

### 3.3 Alternative 7 – Combination of gray infrastructure Alternative 6 and green infrastructure hybrid approach

As discussed earlier, the green infrastructure strategies in The Port inside the two resilient blocks and outside have been modeled in combination with the selected gray infrastructure Alternative 6. This combined alternative is named as Alternative 7.

Figure 34 shows a comparison of flood depths and extent between Alternative 7 (blue layer) and Alternative 6 (purple layer) for the 10-year 24-hour design storm by 2070. The uncovered purple areas in this figure represent those areas that are likely to be not flooded under Alternative 7 compared to Alternative 6. For areas on Bishop Allen Drive, School Street, Cherry Street, Pine Street, Columbia Street, Albany Street, flooding has largely been mitigated and is contained mostly within the right of way in Alternative 7 compared to Alternative 6 for the 10-year storm by 2070. Also, areas between Windsor Street and Porter Street, and between Porter and Galileo Way show much less flooding in Alternative 7 compared to Alternative 6 for the 10-year storm by 2070. In other words, for these areas, incremental implementation of green infrastructure combined with gray infrastructure can significantly reduce the flooding for the 10-year 24-hour storm by 2070. With Alternative 7, within the two resilient blocks, nuisance flooding (flood depths less than 0.5 foot) is observed as expected due to the different modeling technique applied for the resilient blocks<sup>6</sup>. In the mixed-use block, green infrastructure can reduce the flooding in areas between Davis and Moore Streets and on Moore Street.

---

<sup>6</sup> Further details are explained in Attachment 1 technical memo by Stantec titled “Flood Mitigation Alternatives for The Port neighborhood”





Figure 34 – Flood reduction benefits from Alternative 7 (purple = areas that no longer flood) compared to Alternative 5 under a 2070 10-year 24-hour storm

Table 14 compares the flood volumes *within the entire Port area* and Table 15 compares the flood volumes *within The Port area excluding the resilient blocks*. **Alternative 7** compared to the 2020 system conditions provided a significant flood reduction of approximately 3.6 MG, a **77% flood volume reduction** under the 10-year 24-Hour storm by 2070. Of the total 3.6 MG of flood reduction, 3.1 MG can be attributed to Alternative 6, which also includes the stormwater tank at Morgan Park. Therefore, approximately 0.5 MG of flood reduction can be attributed to the incremental implementation of green infrastructure in Alternative 7. Also, with Alternative 7, the flooding from the 10-year storm by 2070 (1.1 MG) is less than the flooding currently experienced in The Port for the present day 10-year storm (1.2 MG). Therefore, with an effective combination of gray and green infrastructure, the City can likely reduce **the flooding from the 10-year storm by 2070 (4.7 MG), such that it is not any worse than the flooding from the present 10-year storm (1.2 MG)**. This indicates that the combined effect of gray and green infrastructure can successfully mitigate the impacts of climate change for some of the smaller and more frequent storms in the future.

Table 14 – Comparison of Alternatives 6 and 7 with the 2020 system conditions for the 10-year 24-hour design storm by 2070

Parameter	Present 10-yr under 2020 system conditions	2070 10-yr under 2020 system conditions	2070 10-yr under Alternative 6 <sup>1</sup>	2070 10-yr under Alternative 7 <sup>1</sup>
Flood Volume (MG) (% volume reduction)	1.2	4.7	1.6 (67%)	1.1 (77%)
% Port Area Flooded	6%	15%	11%	9%
% Port Properties Flooded	15%	29%	25%	25%

<sup>1</sup>Percent reduction compared to revised (2020) system conditions

Table 15 – Comparison of Alternatives 6 and 7 with the 2020 system conditions for the 10-year 24-hour design storm by 2070

Parameter	Present 10-yr under 2020 system conditions	2070 10-yr under 2020 system conditions	2070 10-yr under Alternative 6 <sup>1</sup>	2070 10-yr under Alternative 7 <sup>1</sup>
Flood Volume (MG) (% volume reduction)	1.2	4.7	1.4 (70%)	0.8 (83%)
% Port Area Flooded	6%	15%	11%	6%
% Port Properties Flooded	15%	29%	22%	14%

<sup>1</sup>Percent reduction compared to revised (2020) system conditions

### 3.4 Estimated urban heat island benefit from green infrastructure and white roofs

Combined effects of increased tree canopy, green infrastructure and white roofs have been evaluated in terms of urban heat island (UHI) mitigation for The Port. Based on the different types of green infrastructure discussed in the previous sections, proposed improvements that contribute to reducing UHI in The Port are summarized in Table 16. However, it is important to note that in modeling UHI mitigation benefits, the proposed green infrastructure and white roofs were considered at their maximum extent practicable to test maximum UHI benefits that can be achieved from these strategies.

- 1) Existing tree canopy (2014 tree canopy layer from GIS) in The Port covers an approximate area of 33 acres. With 402 additional trees planted with and without tree box filters, the proposed tree canopy can be increased to 37 acres.

- 2) Existing impervious area in The Port is 140 acres. With implementation of green infrastructure such as rain gardens, porous pavement and green roofs the proposed impervious area can be reduced to 110 acres.
- 3) Existing white roofs in The Port cover approximately 10 acres. With more building roofs being painted white, proposed white roof area can be increased to 30 acres. Roof areas can be painted in white to help reflect radiation, minimizing the amount of heat directed to ground surface. White roofs also help the building to regulate indoor temperature which translates to energy savings.

Table 16 – Summary of metrics contributing to reducing urban heat island impacts

	<b>Tree Canopy (acres)</b>	<b>Impervious Area (acres)</b>	<b>White Roof (acres)</b>
<b>Existing</b>	33 <sup>1</sup>	140 <sup>3</sup>	10
<b>Proposed</b>	37 <sup>2</sup>	110 <sup>4</sup>	30
<b>%change</b>	12%↑	21%↓	200+%↑

<sup>1</sup>Existing tree canopy is based on 2014 tree canopy area

<sup>2</sup>Proposed tree canopy area was determined by adding 402 new trees (to 2014 canopy) with and without tree box filters, assuming canopy growth to 30 feet diameter for the new trees

<sup>3</sup>Existing impervious area is based on the City’s current impervious area GIS layer (last modified in 2015)

<sup>4</sup> Proposed impervious area from implementation of green infrastructure

The City’s UHI model which is raster-based and uses geographical information system (GIS) software is used to generate the UHI maps under the existing and proposed conditions as shown in Figure 35 and Figure 36, respectively. Figure 35 shows that on a day when the average ambient air temperature in the City of Cambridge is 90°F, The Port neighborhood is likely to experience an average temperature of 92°F, with approximately 44% of The Port area experiencing temperatures greater than 92°F. The cooling benefit under proposed conditions from increase in canopy area, decrease in impervious area and increase in white roofs have been estimated using the same relationships as in Appendix B of the CCPR Alewife Plan<sup>7</sup>. Figure 36 shows that under proposed conditions, on a day when the average ambient air temperature in the City of Cambridge is 90°F, The Port neighborhood is likely to experience the same average temperature of 90°F, with approximately 29% of The Port area experiencing temperatures greater than 92°F. This implies that the average UHI temperature in The Port can be mitigated by 2°F and areas experiencing UHI can decrease by 15% with effective implementation of increased trees, other green infrastructure and white roofs. Of this 2°F mitigation in UHI, 1.7°F can be attributed to decreased in impervious area and increase in white roofs, and 0.3°F can be attributed to increase in tree canopy.

<sup>7</sup> Appendix B: Green Infrastructure Analysis and Urban Heat Island Modeling accessed at [https://www.cambridgema.gov/CDD/Projects/Climate/~/\\_media/E793050A9B0F48ABFFBF52924A5D58B.ashx](https://www.cambridgema.gov/CDD/Projects/Climate/~/_media/E793050A9B0F48ABFFBF52924A5D58B.ashx)



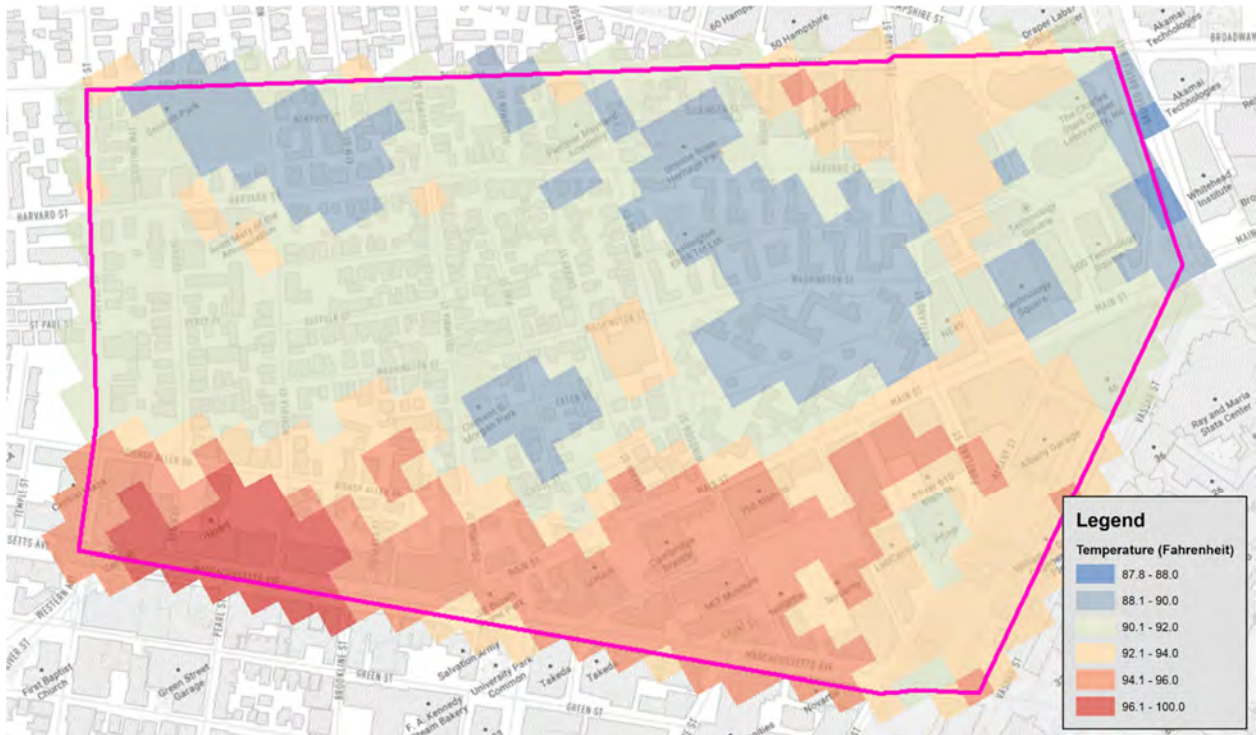


Figure 35 – Ambient temperature on a 90-degree day in The Port under existing conditions

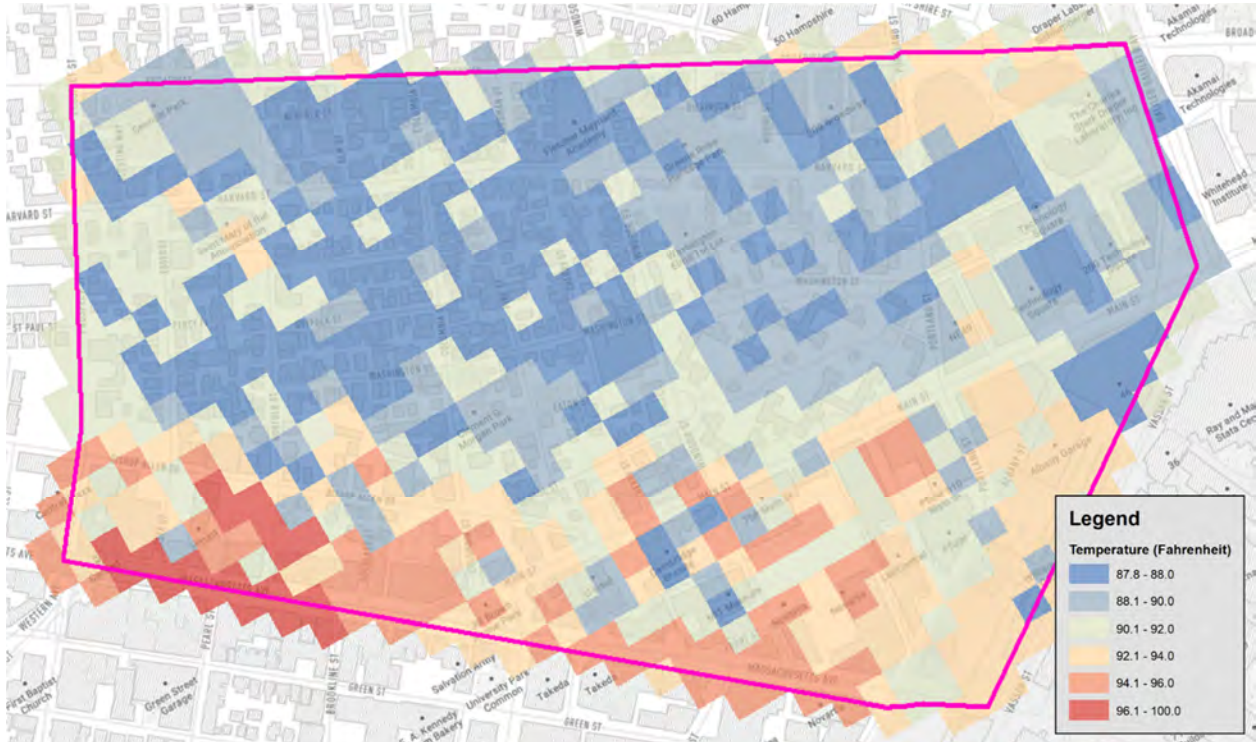


Figure 36 – Ambient temperature on a 90-degree day in The Port with improvements from green infrastructure and white roofs



### 3.5 Estimated water quality benefits

The water quality benefits of green infrastructure were assessed with respect to the total phosphorus (TP) reduction by land use types in The Port. Phosphorus contributes from urban runoff to nutrient in open water bodies. Excess phosphorus loading can lead to harmful algal blooms and negatively affect the water quality of freshwater ecosystems.

Phosphorus Load Export Rates (PLER) for each land use type was based on the rates as defined in an EPA guidance document for MS4 communities<sup>8</sup>. The existing total TP loading is summarized in Table 17, grouped by the five land use types – Commercial, Industrial, High-Density Residential (HDR), Open Space, Medium-Density Residential (MDR) and Public Right-of-Way (PROW).

*Table 17 – Summary of impervious area, phosphorus load export rates and annual Total Phosphorous loading from The Port by land use type*

Land Use Type	Land Use Area (ac)	Impervious area (ac)	%Imperviousness	TP Export Rate (lb./ac/year)	TP annual load (lb./year)
<b>Commercial</b>	56.3	48.5	86%	1.78	86.3
<b>HDR</b>	27.1	20.8	77%	2.32	48.2
<b>Industrial</b>	4.1	3.4	83%	1.78	6.1
<b>Open Space</b>	3.8	2.8	74%	1.52	4.3
<b>MDR</b>	31.8	24.8	78%	1.96	48.7
<b>PROW</b>	40.0	33.7	84%	1.34	45.2
<b>Total</b>	163.1	134.1	80% (Average)		238.8

The total phosphorus removed for each type of green infrastructure is estimated based on a MS4 general permit documentation from the USEPA<sup>9</sup>. The methodology correlates land-use type and the percentage reduction of directly-connected impervious area to extrapolated from performance curves of various green infrastructure types. Table 16 shows a sample output of the calculations performed for the subcatchments in The Port with a breakdown of the percent impervious area in each drainage catchment being captured by each green infrastructure type, the sum of the total phosphorus removed, and the percent phosphorous removed for each drainage catchment area.

<sup>8</sup> Attachment 1- Fact Sheet Massachusetts Small MS4 Charles River Basin Nutrient (Phosphorus) TMDLs, Phosphorus Load Export Rates and BMP Performance  
<sup>9</sup> 2014 MA MS4 General Permit – Appendix F Attachment 3

Table 18 – Sample of Total Phosphorous removal calculations by subcatchments

subcatchment	DCIA (ac)	% DCIA Treated by Rain Garden	% DCIA Treated by Porous Pavement	% DCIA Treated by Green Roof	% DCIA Treated by Leaching CB	% DCIA Treated by Tree Box Filter	Total TP Removal (lbs)	Percent Removed
181 Mass Ave	1.55	0%	0%	20%	0%	0%	0.3892	15%
610 MainSt	2.81	0%	0%	26%	1%	1%	0.9438	20%
935040	3.75	0%	0%	11%	1%	1%	0.4864	9%
CAM103	0.90	0%	0%	0%	0%	0%	0.0034	0%
CAM112	2.97	0%	0%	6%	0%	0%	0.1892	4%
CAM113	5.43	0%	0%	3%	1%	0%	0.2077	2%
CAM114	2.11	0%	0%	2%	0%	0%	0.0537	2%
CAM118	4.89	0%	0%	5%	0%	0%	0.2849	4%
CAM120	7.74	0%	0%	14%	4%	2%	1.7840	14%
CAM121	0.96	0%	0%	0%	2%	1%	0.0245	1%
CAM122	14.56	0%	0%	6%	0%	0%	1.1008	5%

From the existing TP loading of 239 pounds/year in The Port neighborhood, the modeled green infrastructure in this study are estimated to remove approximately 31 pounds/year. The area-weighted average TP removal rate considering land use type is approximately 15%. Results in Figure 37 show that rain gardens are credited for approximately 54% of the TP removed, followed by 27% for green roofs. Tree box filters and leaching catch basins provided lower TP removal rate due to the poor native soil conditions in The Port, as most of the neighborhood is categorized to have a USDA Hydrologic Soil Group C, which has a relatively low hydraulic conductivity rate for water to permeate.

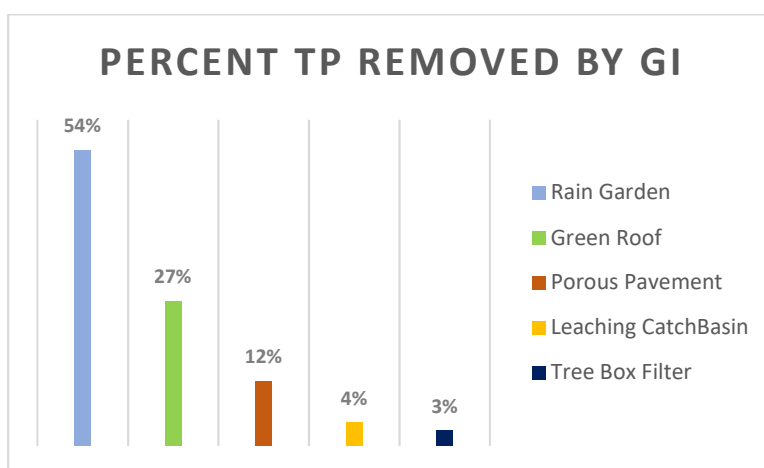


Figure 37 – Percentage relative contribution of phosphorus removal per green infrastructure type

### 3.6 Green infrastructure key findings

The combined green and gray infrastructure model (Alternative 7) simulates the performance of green infrastructure with a hybrid approach. Two resilient blocks representing distinct characteristics of The Port were chosen to implement green infrastructure at higher levels of implementation; whereas for the rest of The Port, lower and more practical levels of implementation were used. Alternative 7 results in 1.1 MG of flooding for the 10-year 24-hour storm by 2070, which is comparable to the 1.2MG of flooding for the present day 10-year 24-hour storm under the 2020 system conditions. This implies that an effective combination of gray and green infrastructure can successfully compensate for the increased flood volumes due to climate change for some of the smaller more frequent storms, such as the 10-year storms. The incremental flood reduction benefit from green infrastructure in The Port is approximately 0.5 MG, which is the difference in flood volume between Alternative 6 (1.6 MG) and Alternative 7 (1.1 MG).

Increased trees, green infrastructure and white roofs can also mitigate the UHI effect in The Port by lowering the average ambient air temperature in The Port by 2°F. These strategies can also decrease the percent of The Port area experiencing the UHI effect by 15%.

Effective implementation of green infrastructure can reduce the total phosphorus loading from The Port by approximately 31 pounds/year, which constitutes of an area weighted average removal of total phosphorous by 15%.

However, since Alternative 7 involves aggressive implementation of green infrastructure, the City will likely need to proceed with a more detailed green infrastructure feasibility analysis for The Port to validate the findings from this study.

## 4 Short-duration high-intensity storms analyses

Short-duration, high-Intensity storms, such as the July 10, 2010 storm can have flood impacts that may be significantly different in terms of extent, depth and duration compared to the typical 24-hour design storms or other longer duration storms. One of the main challenges of these storms is that the stormwater collection inlets, such as catch basins / surface drains are typically not designed to handle such storm events. The inlet capacity limitation causes localized flash floods in areas that may otherwise not be affected during long-duration storms.

As with the 24-hour design storms, 2-hour design storm projections have also been developed for the City. Table 19 summarizes the projected rainfall depths (in inches) for the 2-hour design storms for the 10-, 25- and 100-year recurrence intervals for present, 2030 and 2070 planning horizons. Similar to the findings for the 24-hour design storms, the 25-year 2-hour design storm of present (2.7 inches) is likely to be the 10-year 2-hour design storm by 2070 (2.6 inches), and the 100-year 2-hour design storm of present (3.9 inches) is likely to be the 25-year 2-hour design storm by 2070 (3.3 inches).

Table 19 – Comparison of rainfall depths (in inches) for the 2-hour duration design storms in the City of Cambridge

	Present-Day (in.)	2030s(in.)	2070s (in.)
10-Year 2-Hour	2.1	2.3	2.6
25-Year 2-Hour	2.7	2.9	3.3
100-Year 2-Hour	3.9	4.0	4.6

Another important consideration for short duration storms is the distribution of the rainfall pattern. Figure 38 shows rainfall intensity plotted against time to demonstrate options of how the present 100-year storm can be distributed over the 2-hour period.

- The purple line shows the actual distribution of the July 10, 2010 storm, where peak intensity was observed as 4.62 in/hr at 15-min interval. However, since the rainfall was every 15 mins during the 2hr period, the rain gage may have failed to record the peak of the storm, which may have happened between that 15-min interval.
- The orange line shows the present 100-year 2-hour storm (3.9 in) with peak intensity at 5.06 in/hr, if it were to be distributed same as the July 10, 2010 storm at the same 15-min interval.
- The green line shows the SCS Type III distribution for the present 100-year 2-hour storm (3.9 in) with peak intensity at 6.55 in/hr at 6-min interval.
- The red line shows the same SCS Type III distribution for the present 100-year 2-hour storm (3.9 in) with peak intensity at 4.94 in/hr at 12-min interval. This line just demonstrates how coarsening of the time step for the same distribution results in a smaller peak.



The hydrologic/hydraulic model for The Port was evaluated for the short duration storms using the SCS Type III rainfall distribution at 6-minute time increments (option c in above list). Using the 6-minute rainfall time interval was considered appropriate to analyze inlet capacity limitations which are important to understand for short duration storms. To determine flooding effects at the peak of the storm, smaller time steps compared to 15-minutes need to be looked at. Since the SCS Type III rainfall distribution pattern has been used for all the 24-hour duration storms, the same distribution was used for short duration storms to be consistent. Further details on the modeling approach and results are included in Attachment 1 technical memo by Stantec titled “Flood Mitigation Alternatives for The Port neighborhood”.

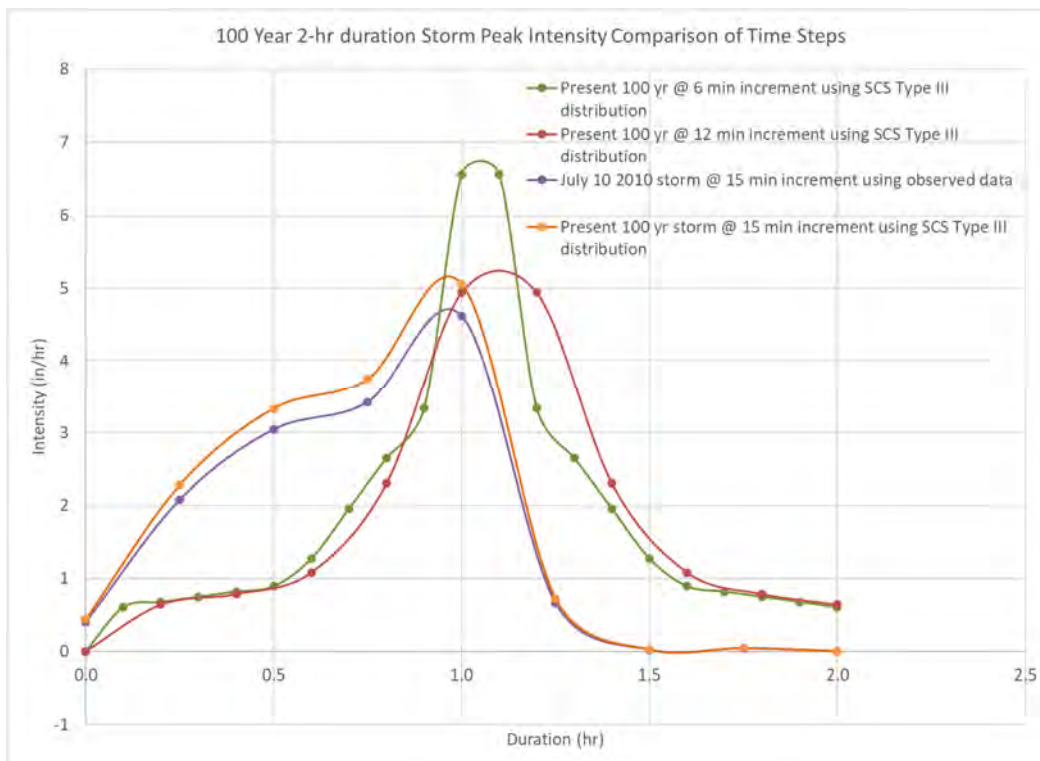


Figure 38 – Examples of design storm distribution for short duration, high intensity storms in Metro Boston area

Figure 39 presents a comparison between flood depth, extent and flood elevations for the 10-year 24-hour storm (blue layer) and the 10-year 2-hour storm (purple layer) by 2070. The uncovered purple areas in this figure represent those areas that are likely to be flooded under the 2-hour storms compared to the 24-hour storms. For areas that experience flooding from both types of storms, the peak flood elevations have been compared between the two storm types. The areas in the two darker shades of green correspond to those areas where the peak flood elevation from the 10-year storm 2-hour storm by 2070 is lower by up to 0.5 ft or more compared to the peak flood elevation from the 10-year 24-hour storm by 2070. The areas in light green and yellow correspond to those areas where the peak flood elevation from the 10-year storm 2-hour storm by 2070 is higher by up to 0.3 ft compared to the peak flood elevation from the 10-year 24-hour storm by 2070. The areas in orange and shades of red

correspond to those areas where the peak flood elevation from the 10-year storm 2-hour storm by 2070 is higher by up to 1.0 ft or more compared to the peak flood elevation from the 10-year 24-hour storm by 2070. This type of comparison is important since the City is recommending that new buildings in the City be designed/protected to the 10-year storm by 2070 and be able to recover from the 100-year storm by 2070. However, prior to this comparison, flood elevations from only the 24-hour design storms had been considered as part of these recommendations. Model results show that Ashburton Place, labeled with a red star in Figure 39, may experience severe flash flood problems due to a combined impact from limited downstream conveyance capacity and restricted inlet capacity.

A series of flood mitigation options for the short duration storms have been evaluated and summarized in the Attachment 1 technical memo by Stantec titled “Flood Mitigation Alternatives for The Port neighborhood”.



Figure 39 – Comparison of flood depths and flood elevations between the 10-year 24-hour design storm and the 10-year 2-hour design storm by 2070.

## 5 Summary of model results and next steps

Building upon the CCPR plan for Alewife, this study identified best strategies/alternatives that are most applicable to mitigate flooding, improve water quality and reduce the urban heat island effect for The Port. Table 20, Table 20 and Table 21 compare the flood volumes (and percent reduction compared to 2020 system conditions), percent of The Port area flooded, and percent of properties flooded in The Port across various alternatives for three planning horizons present, 2030 and 2070, respectively. For the 10-year storm, Alternative 7, which is an effective combination of gray and green infrastructure is able to almost eliminate present day and 2030 flooding and reduce the 2070 flooding by 77%.

*Table 20 – Results for gray and green infrastructure alternatives compared to the 2020 system conditions for the present 10-year 24-hour design storm*

Parameters	2020 System Condition	Alternative 1	Alternative 2	Alternative 3	Alternative 4	Alternative 5	Alternative 6	Alternative 7
Flood Volume, MG (%Reduction <sup>1</sup> )	1.2	0.04 (100%)	0.04 (100%)	0.1 (92%)	0.04 (100%)	0.1 (92%)	0.02 (100%)	0.1 (92%)
% Area Flooded	6%	2%	1%	2%	1%	2%	1%	2%+
% Properties Flooded	15%	7%	3%	3%	3%	3%	5%	12%+

<sup>1</sup>Percent reduction compared to 2020 system conditions under present day 10-year 24-hour design storm

*Table 21 – Results for gray and green infrastructure alternatives compared to the 2020 system conditions for the 2030 10-year 24-hour design storm*

Parameters	2020 Systems Condition	Alternative 1	Alternative 2	Alternative 3	Alternative 4	Alternative 5	Alternative 6	Alternative 7
Flood Volume, MG (%Reduction <sup>1</sup> )	2.6	0.4 (85%)	0.3 (88%)	0.5 (81%)	0.3 (88%)	0.6 (77%)	0.2 (92%)	0.2 (92%)
% Area Flooded	10%	5%	3%	4%	3%	4%	4%	3%+
% Properties Flooded	22%	12%	5%	6%	4%	7%	12%	17%+

<sup>1</sup>Percent reduction compared to 2020 system conditions under 10-year 24-hour design storm by 2030



Table 22 – Results for gray and green infrastructure alternatives compared to the 2020 system conditions for the 2070 10-year 24-hour design storm

Parameters	2020 System Condition	Morgan Tank Only	Alternative 1	Alternative 2	Alternative 3	Alternative 4	Alternative 5	Alternative 6	Alternative 7
Flood Volume, MG (%Reduction <sup>1</sup> )	4.7	2.1 (55%)	1.8 (62%)	1.4 (70%)	1.9 (60%)	1.2 (74%)	2.0 (57%)	1.6 (66%)	1.1 (77%)
% Area Flooded	15%	N/A	12%	8%	10%	8%	11%	11%	9%
% Properties Flooded	29%	N/A	25%	17%	19%	16%	21%	25%	26%

<sup>1</sup>Percent reduction compared to 2020 system conditions under 10-year 24-hour design storm by 2070

Figure 40 depicts the comparison in terms of flood volume for each alternative against the target of 1.2MG, which is the flood volume for the present 10-year 24-hour storm under 2020 system conditions. The City agreed that flood mitigation strategies in The Port at a minimum need to be able reduce the flooding from the 10-year storm by 2070 (4.7 MG), such that the flooding from the 10-year storm by 2070 is no worse than the present 10-year storm (1.2 MG). Alternative 7 results in 1.1 MG of flooding for the 10-year 24-hour storm by 2070, which is comparable to the 1.2 MG of flooding for the present day 10-year 24-hour storm under the 2020 system conditions. This implies that an effective combination of gray and green infrastructure can successfully compensate for the increased flood volumes due to climate change for some of the smaller more frequent storms, such as the 10-year storms.

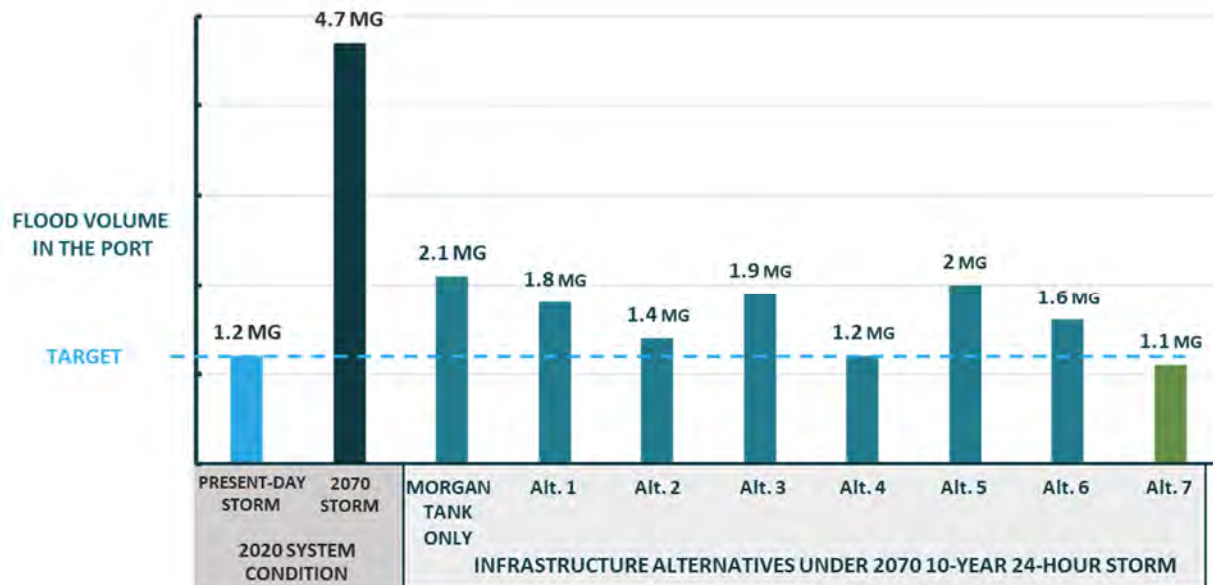


Figure 40 – Flood volumes for the 10-year 24-hour storm by 2070 for all alternatives



This study demonstrated the effectiveness of a combined gray and green infrastructure alternative to mitigate present and future flooding for The Port neighborhood. With an opportunistic approach to implement green infrastructure, the implementation can provide additional benefits to mitigate the UHI effect and improve water quality in the area. Green infrastructure and white roofs can lower the ambient temperature by an average of 2°F on a 90°F-day in The Port neighborhood. The infiltration properties of green infrastructure can also remove approximately 31 pounds of Total Phosphorous per year, equivalent to 15% of the phosphorous loading in The Port. As next steps, the City will need to further conduct detailed feasibility analysis of the proposed alternative(s), develop conceptual design and proceed with final design and construction of the strategies in the proposed alternative(s), if deemed appropriate.

**THE PORT PREPARDNESS PLAN  
APPENDIX 1: ATTACHMENT 1**

**FLOOD MITIGATION ALTERNATIVES  
FOR THE PORT NEIGHBORHOOD**

**Prepared by Stantec**

**April 2019**

**For**

**Kleinfelder**

---

To:	Kathy Watkins, Owen O’Riordan, Jim Wilcox Cambridge DPW	From:	David Bedoya, Yovanni Catano, Eudora Zhang, Katie Chamberlain Stantec
File:	U:\195130026\Study\2nd Pilot Study-The Port\Deliverables\TM	Date:	March 18, 2019

---

**Reference: Cambridge Climate Change Preparedness and Resiliency – Flood Mitigation Alternatives for The Port Neighborhood**

This memorandum provides a brief description of the hydraulic and inundation modeling efforts performed for the Port Neighborhood Pilot Project, which is part of Cambridge’s Climate Change Preparedness and Resiliency (CCPR) effort. This modeling effort had two main objectives:

1. To identify gray and green stormwater infrastructure alternatives that were effective at mitigating flooding under current and projected 10-year, 24-hour storm events; and
2. To evaluate system performance using the selected gray infrastructure alternative under short duration storm event conditions and evaluate methods of reducing flooding under these rainfall conditions.

Part 1 of this memorandum describes the analysis performed to identify the most advantageous gray and green infrastructure (GI) alternative from a flood mitigation and constructability point of view.

The modeling results showed that implementation of gray infrastructure alternatives would help reduce flooding risk derived from changes in precipitation due to climate change. As expected, the largest reduction in flood volumes in the Port area are provided by alternatives that remove the largest amount of flows from the combined sewer systems. Due to its high-effectiveness in flood reduction as well as the high degree of existing infrastructure reuse, Alternative 6 was selected as the most advantageous gray infrastructure alternative. Alternative 6 would drastically reduce damaging flooding in the Port area during the 10-year, 24-hour design storm in present climate conditions (0.02MG) and in 2070 climate conditions (from 5.63MG in 2015 system conditions down to 1.56MG).

Green infrastructure could potentially reduce another 0.4-0.5MG of flooding beyond Alternative 6 in the 2070 time horizon. This additional reduction would mean that flooding in the Port area in 2070 would be below current climate flood estimates in 2020 system conditions.

Part 2 of this document evaluates system performance under short duration events and under different system conditions. The modeling results show that flooding generated by short duration storms can be as significant or greater than flooding generated by the 24-hour events. Based on these results, it is clear that the conveyance system is not configured to provide flood relief for short but very intense storms. The results are inconclusive regarding the system inlet capacity because the system gets overwhelmed too quickly in the modeled storm event.

Reference: Cambridge Climate Change Preparedness and Resiliency – Flood Mitigation Alternatives for The Port Neighborhood

## **Part 1: Evaluation of Green and Gray Infrastructure Alternatives**

Several flood mitigation alternatives were evaluated using the City of Cambridge’s Infoworks ICM v7.5 hydraulic sewer model. The sewershed area (CAM017) within the City-wide model was last calibrated in 2018 as part of the CSO annual reporting effort. The 10-year, 24-hour storm event in present, 2030 and 2070 climate conditions were used for this assessment. The 2015 and 2020 system conditions models were used as the flood volume baseline to compare against the different analyzed alternatives. A brief description of the 2015, 2020 and alternative system conditions models as well as respective model results are provided below.

### **2015 and 2020 System Conditions Model**

The most up to date hydraulic model for the City of Cambridge represents system conditions as of 2015. This model was modified to include projects that are currently under design or under construction and are expected to be completed by 2020. These projects are listed below and shown in Figure 1:

- Parking Lot 6 (PL6) stormwater tank and pump station currently being constructed by the City of Cambridge
- Project 9ab area sewer separation currently being constructed by North Point’s developer Divco
- Infiltration/Inflow (I/I) removal projects from streets adjacent to Rogers Street Park currently under design.
- I/I removal projects from First and Third streets projects currently under design.
- Monsignor O’Brien Highway (MOB) drain, sewer separation, and Lechmere Canal outfall currently under design by North Point’s developer Divco.
- Talbot Street outfall currently being constructed by MIT.
- Cambridgeport sewer separation with new Cottage/Lopez storm drain currently being constructed by the City of Cambridge.
- Upsizing Broad Canal Drain from 54 to 72 inches along Broad Canal Way. This project is likely to be assigned to MIT as part of the new Volpe development.
- Willard Street sewer separation and outfall currently under design by the City of Cambridge.
- CAM005 outfall pipe free of sediment to reflect cleaning operations.





Figure 1. Projects assumed completed in the 2020 system conditions model



---

### **Green and Gray Infrastructure Alternatives**

**Gray Infrastructure Alternatives:** All gray infrastructure alternatives assumed 2020 system conditions but also included completion of the Clement Morgan Park storm and sanitary tanks and associated sewer separation of the area tributary to the tank (70 acres approximately). The following gray infrastructure alternatives were modeled.

Alternative 1: This alternative included representation of the following and as shown in Figure 2:

- Separation of all common manholes along Harvard Street from Portland Street to Dana Street and removal of illicit connections to the Harvard Street drain
- Closure of any cross-connections between the Cambridge Branch Sewer and the Portland Street combined sewer between Main Street and Harvard Street.
- Installation of a backflow preventer on the Portland Street combined sewer downstream of the connection with the Harvard Street drain.
- Repurposing the Albany Street combined sewer by converting it into a storm drain connected to the South Mass Ave storm system.
- Reconfiguration of the junction structure on Main at Portland Street to eliminate cross-connections between the 42-inch storm siphon and the Main Street and Portland Street sanitary pipes.
- Connect the 42-inch storm siphon in Main Street to the junction structure at the head of the North Charles Relief Sewer (NCRS) and remove or redirect sanitary connections away from the junction structure and into the NCRS.

March 18, 2019

Kathy Watkins, Owen O'Riordan, Jim Wilcox

Page 5 of 25

Reference: Cambridge Climate Change Preparedness and Resiliency – Flood Mitigation Alternatives for The Port Neighborhood



**Figure 2.** Actions needed and separated area tributary to the Albany Street conduit under Alternative 1



Reference: Cambridge Climate Change Preparedness and Resiliency – Flood Mitigation Alternatives for The Port Neighborhood

Alternative 2: This alternative consists of separating the Hampshire Street stormwater catchment area. The main items for this alternative include:

- Extension of the Broadway drain from the current end-of-line point at Broadway and Galileo Galilei Street to the intersection between Hampshire Street and Cardinal Medeiros Ave. This new conduit was also assumed to be 72 inches in size.
- Provide an overflow weir over the Binney Street combined sewer at the intersection between Hampshire Street and Cardinal Medeiros Ave and connect it to the Hampshire Street drain and the proposed 72-inch drain described above.
- Perform sewer separation in the Hampshire Street catchment of approximately 110 acres in size. The approximate separation area is shown in Figure 3.



**Figure 3.** Alternative 2 proposed sewer separation of the Hampshire St catchment



March 18, 2019

Kathy Watkins, Owen O'Riordan, Jim Wilcox

Page 7 of 25

Reference: Cambridge Climate Change Preparedness and Resiliency – Flood Mitigation Alternatives for The Port Neighborhood

**Alternative 3:** This alternative consists of redirecting stormwater from areas north of Binney Street, east of Fulkerson Street, and along Cambridge Street (between Sciarappa and Eighth Street). Flows would be redirected towards the adjacent Lechmere Canal stormwater system. Areas to be redirected are shown in Figure 4. Since adding new flows to the Lechmere system would exacerbate flooding in the Lechmere catchment, this alternative assumed that a stormwater storage system would need to be built at Ahern Park. A tank storage volume of 2.4MG was assumed for this modeling exercise at Ahern Park.



**Figure 4.** Alternative 3 proposed separation and redirection area and location of proposed storage tank



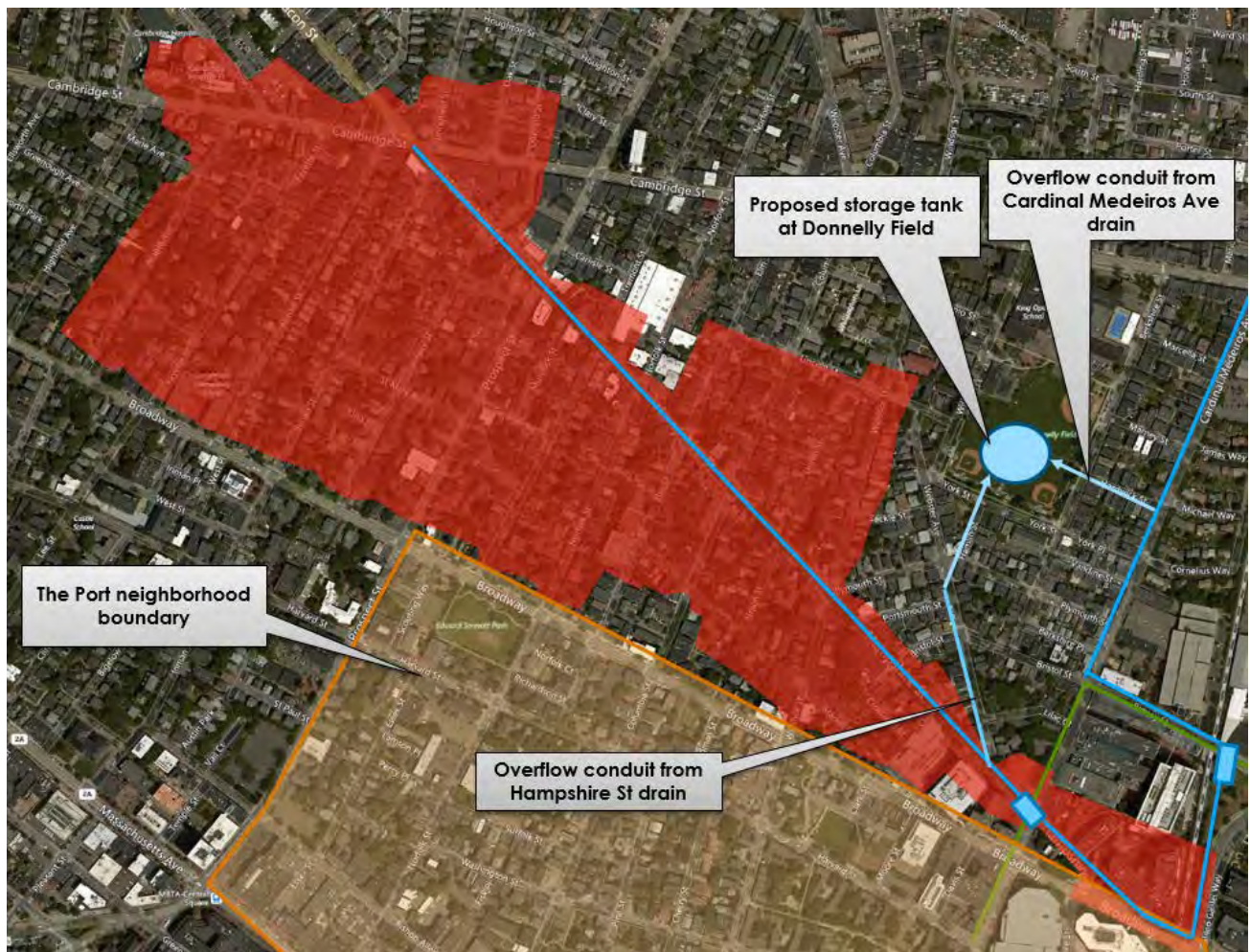
March 18, 2019

Kathy Watkins, Owen O’Riordan, Jim Wilcox

Page 8 of 25

Reference: Cambridge Climate Change Preparedness and Resiliency – Flood Mitigation Alternatives for The Port Neighborhood

**Alternative 4:** This alternative is similar to Alternative 2 but includes a stormwater storage system at Donnelly Field. The storage system is assumed to be fed via two overflow, inlet weirs. The first weir would capture excess flows from the Hampshire Street drain and convey them to the storage system via a conduit along Webster Avenue. The second weir would capture excess flows from Project 9ab and convey them to the storage system via a new drain along Hardwick Street. A stormwater storage volume of 1.6MG was assumed for this modeling exercise. Figure 5 depicts the Alternative 4 infrastructure.



**Figure 5.** Alternative 4 Hampshire Street stormwater catchment area with proposed storage tank at Donnelly Field and overflow conduits (builds on Alternative 2)

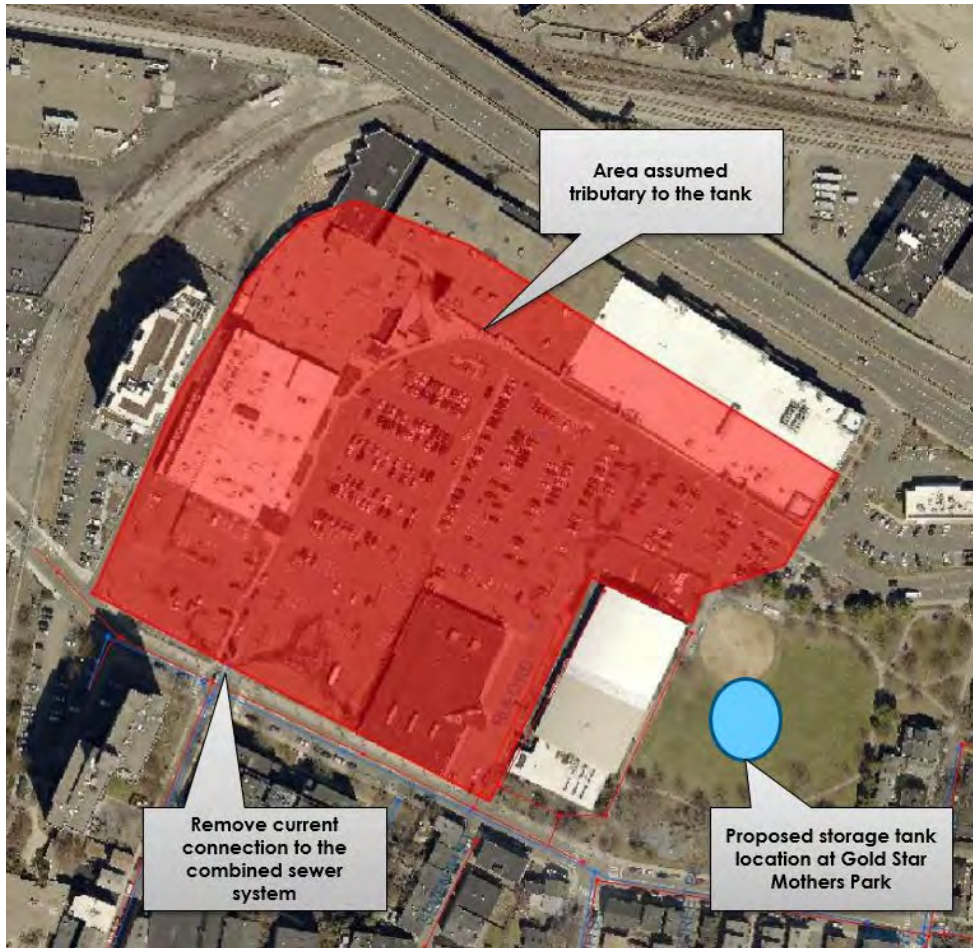
March 18, 2019

Kathy Watkins, Owen O'Riordan, Jim Wilcox

Page 9 of 25

Reference: Cambridge Climate Change Preparedness and Resiliency – Flood Mitigation Alternatives for The Port Neighborhood

Alternative 5: This alternative consists of capturing stormwater runoff from the Twin City Plaza parking lot and roofs and directing it to a stormwater storage system located in the adjacent Gold Star Mothers Park. Approximately, a total of 1.4MG of stormwater storage would be required to fully capture the 10-year, 24-hour, 2070 event. Stormwater would then be pumped to the proposed Monsignor O'Brien Highway storm drain after the storm passed. Alternative 5 conceptual layout is shown in Figure 6.



**Figure 6.** Alternative 5 concept layout



March 18, 2019

Kathy Watkins, Owen O’Riordan, Jim Wilcox  
Page 10 of 25

Reference: Cambridge Climate Change Preparedness and Resiliency – Flood Mitigation Alternatives for The Port Neighborhood

Alternative 6: This alternative is similar to Alternative 1, but also includes the following elements (as shown in Figure 7):

- Remove two common manholes on the south side of Main Street between Portland and Albany streets and bulkhead storm drain in Portland Street.
- Remove illicit connections to the drain along Main Street between Portland and Ames Street.
- Build a new 36-inch drain along Albany Street connecting the existing Main Street drain on its upstream side to the South Mass Ave drain on the downstream side. The connection to the South Mass Ave drain would consist of an overflow weir with a crest elevation of 13.8ft-CCB to prevent river backups into the new drain.

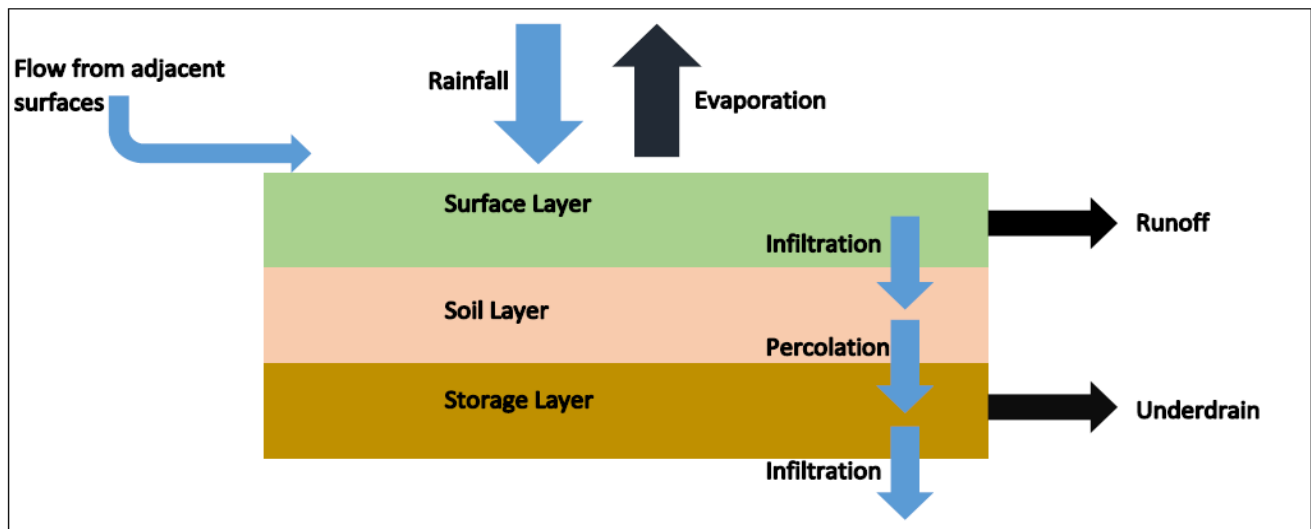


**Figure 7.** Actions needed for Alternative 6 (beyond Alternative 1) and separated area tributary to the Mass Ave drain

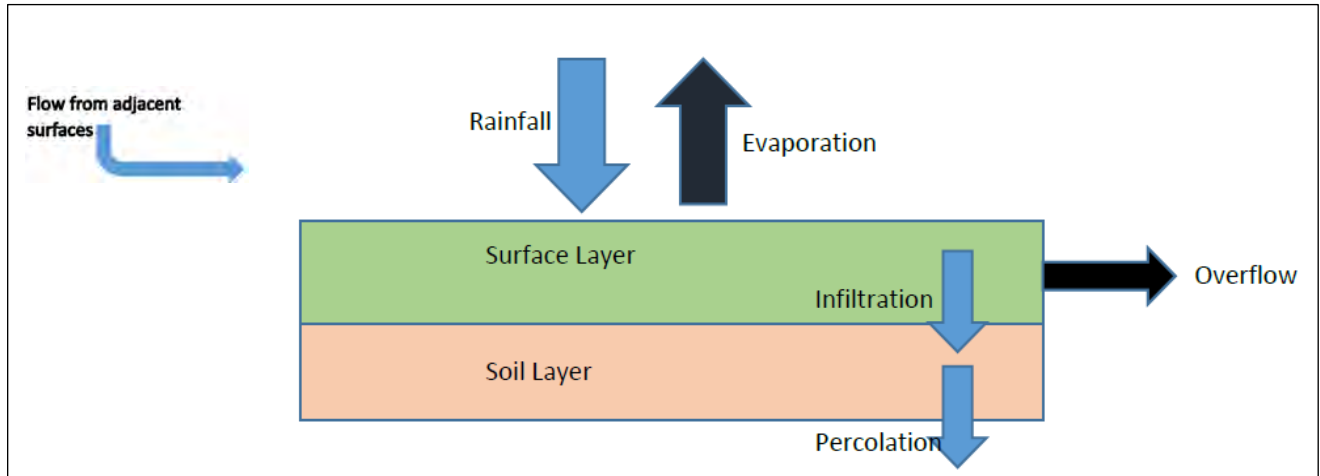
**Green Infrastructure Alternatives:**

One green infrastructure scenario was evaluated and named Alternative 7. This GI alternative built upon Alternative 6. Therefore, it included all Alternative 6 gray infrastructure improvements and added GI on top it. This alternative consisted of modeling green infrastructure across the entire Port neighborhood area in combination with two “resilient blocks” with a higher degree of GI implementation. A summary of the neighborhood-wide level of GI implementation is provided in Table A.1 in Appendix A. Table A.2 in Appendix A also provides the assumed modeling parameters for the different GI technologies and GI layers. The different GI features to be modeled on a subcatchment basis along with GI properties and capture area were provided to Stantec by Kleinfelder A depiction of typical GI profiles with the different parameters used in the modeling process are provided in Figure 8 through 10 below. The GI infrastructure modeled within the resilient blocks is depicted in **Figure 11**.

The modeling approach for Alternative 7 was slightly different than that used for the gray alternative analysis. For areas outside of the resilient blocks, subcatchments were used to generate runoff that would only be routed on the ground surface if a spill occurred at a system node (usually manholes). This is the same approach used for the gray alternatives. Within the resilient blocks however, rainfall was modeled physically as falling on the ground mesh and routed on the ground surface until it reached a sewer surface inlet, infiltrated, or ponded in a low lying area.

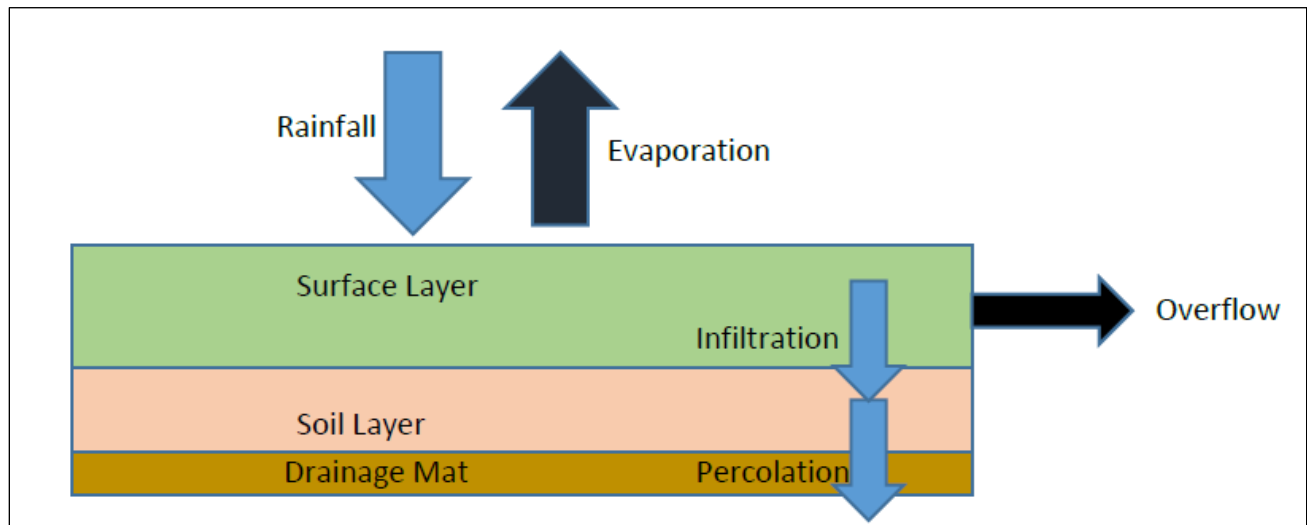


**Figure 8.** Conceptual model of a GI feature with three active layers (e.g. bioretention cell).  
Source: *Sustainable Urban Drainage Modeling in Infoworks ICM, Innovyze, Inc*



**Figure 9.** Conceptual model of a GI feature with two active layers (e.g. rain garden).

Source: Sustainable Urban Drainage Modeling in Infoworks ICM, Innovyze, Inc

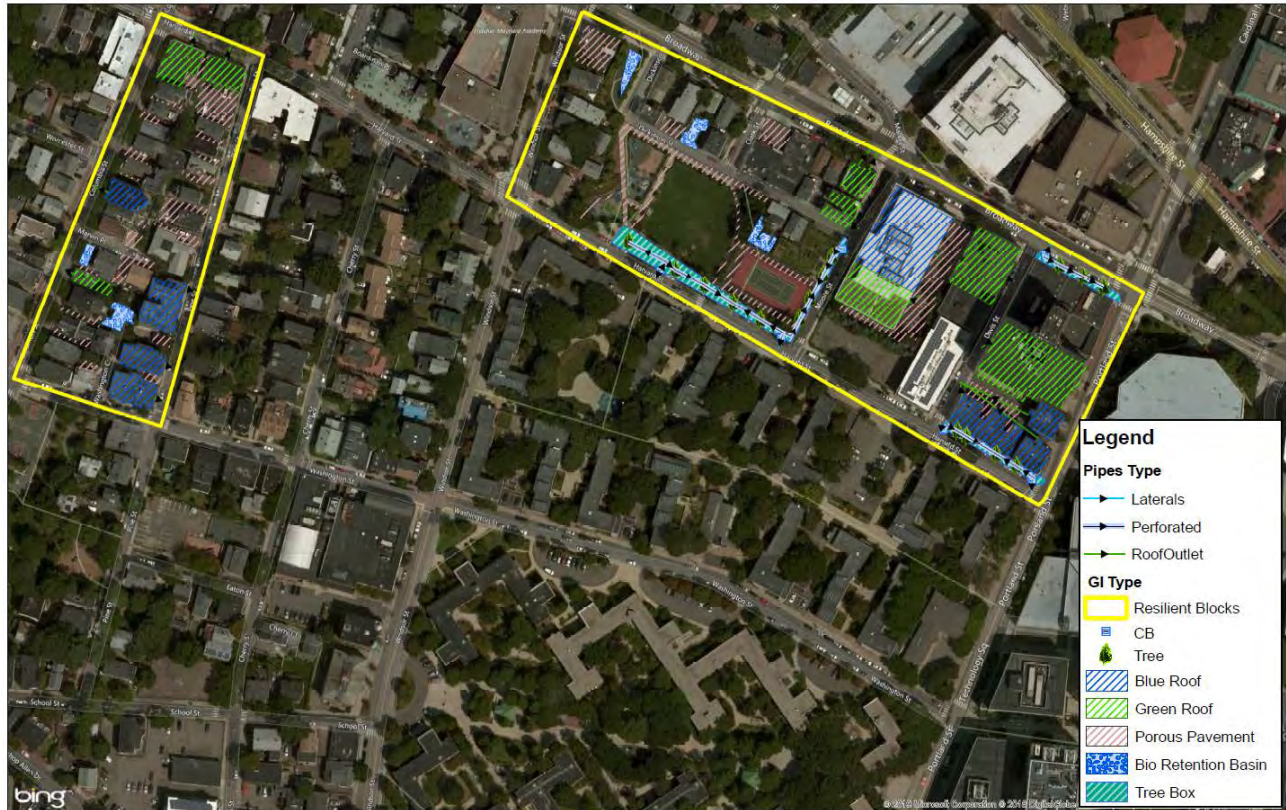


**Figure 10.** Conceptual model of a GI feature with two active layers and a bottom drainage mat (e.g. green roof).

Source: Sustainable Urban Drainage Modeling in Infoworks ICM, Innovyze, Inc



Reference: Cambridge Climate Change Preparedness and Resiliency – Flood Mitigation Alternatives for The Port Neighborhood



**Figure 11.** Plan view of the two resilient blocks modeled

### **Model Results**

The 2015, 2020 and alternative conditions models were run for the 10-year, 24-hour events in present, 2030 and 2070 rainfall conditions. Peak flood volumes in the Port area generated by these storms are provided in Table 1. Peak flood depth maps for the same events are provided in Appendix B for:

- The 2015, 2020 conditions
- The gray infrastructure alternative that was considered by the City of Cambridge as the most advantageous and feasible (i.e. Alternative 6)
- The green infrastructure alternative (Alternative 7) that built upon the selected gray infrastructure alternative (Alternative 6).

Hydrographs before and after implementation of Green Infrastructure (i.e. Alternative 6 versus Alternative 7) at the three piped outlets for the Port area are provided in Figure 12 through Figure 14.

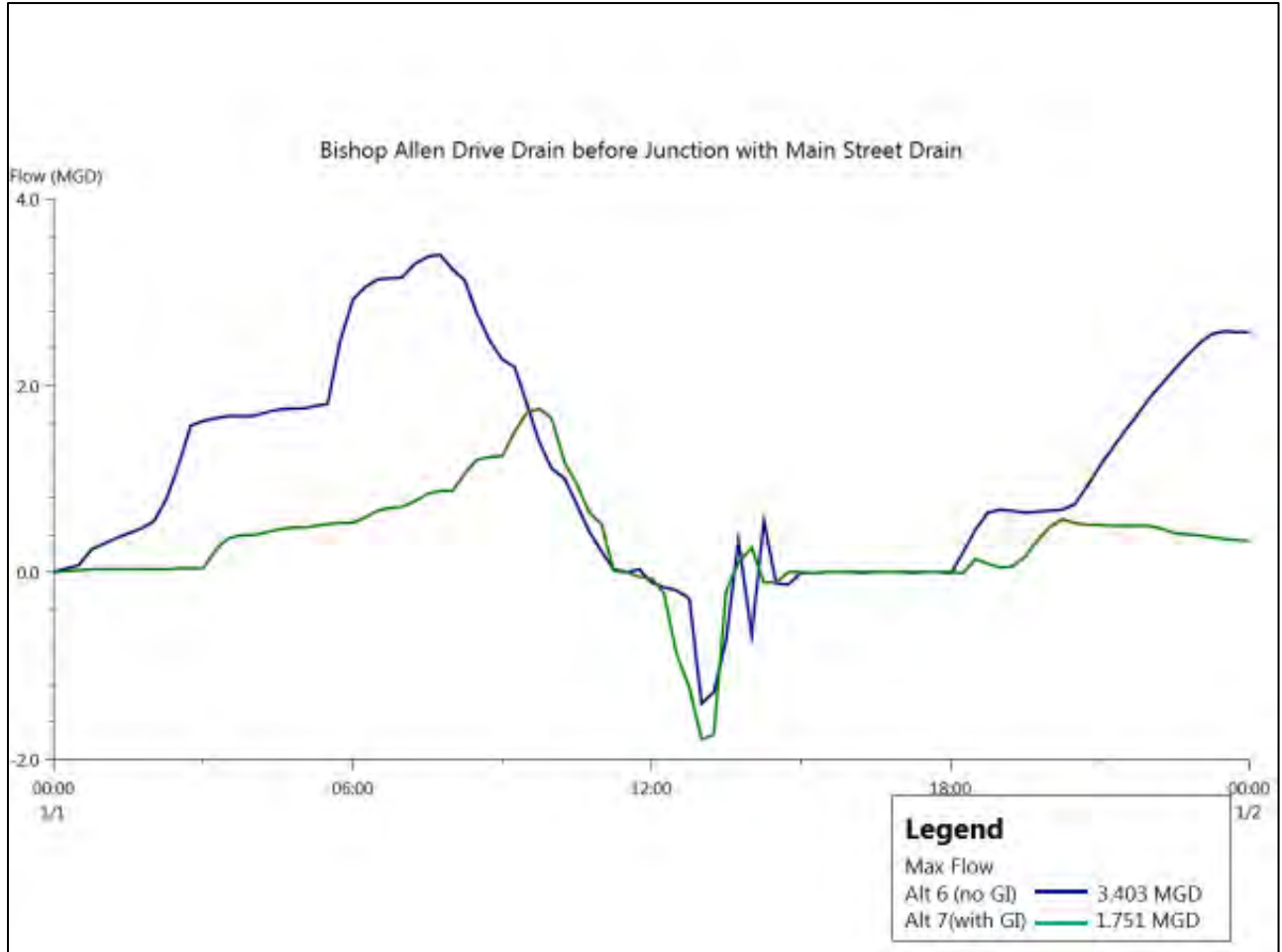
Reference: Cambridge Climate Change Preparedness and Resiliency – Flood Mitigation Alternatives for The Port Neighborhood

**Table 1. Peak Flood Volumes in Port Area under the 10-year, 24hr Design Storm**

<b>Volume (MG)</b>	<b>10y, 24hr Present</b>	<b>10y, 24hr 2030</b>	<b>10y, 24hr 2070</b>
<b>2015 Conditions</b>	2.36	3.7	5.63
<b>2020 Conditions</b>	1.24	2.57	4.71
<b>Alt 1</b>	0.04	0.35	1.79
<b>Alt 2</b>	0.04	0.28	1.37
<b>Alt 3</b>	0.11	0.52	1.88
<b>Alt 4</b>	0.04	0.27	1.24
<b>Alt 5</b>	0.14	0.61	2.05
<b>Alt 6</b>	0.016	0.21	1.56
<b>Alt 6 (no resilient blocks)*</b>	0.013	0.16	1.37
<b>Alt 7 (no resilient blocks)*</b>	0.010	0.09	0.84

\*Flood volumes do not include any flooding within the resilient blocks boundaries in order be able to compare alternative 6 and 7 using the same baseline. Alternative 7 models the resilient blocks with “rainfall on the mesh” and therefore, likely to generate larger flood volumes because the whole ground extent gets wet.

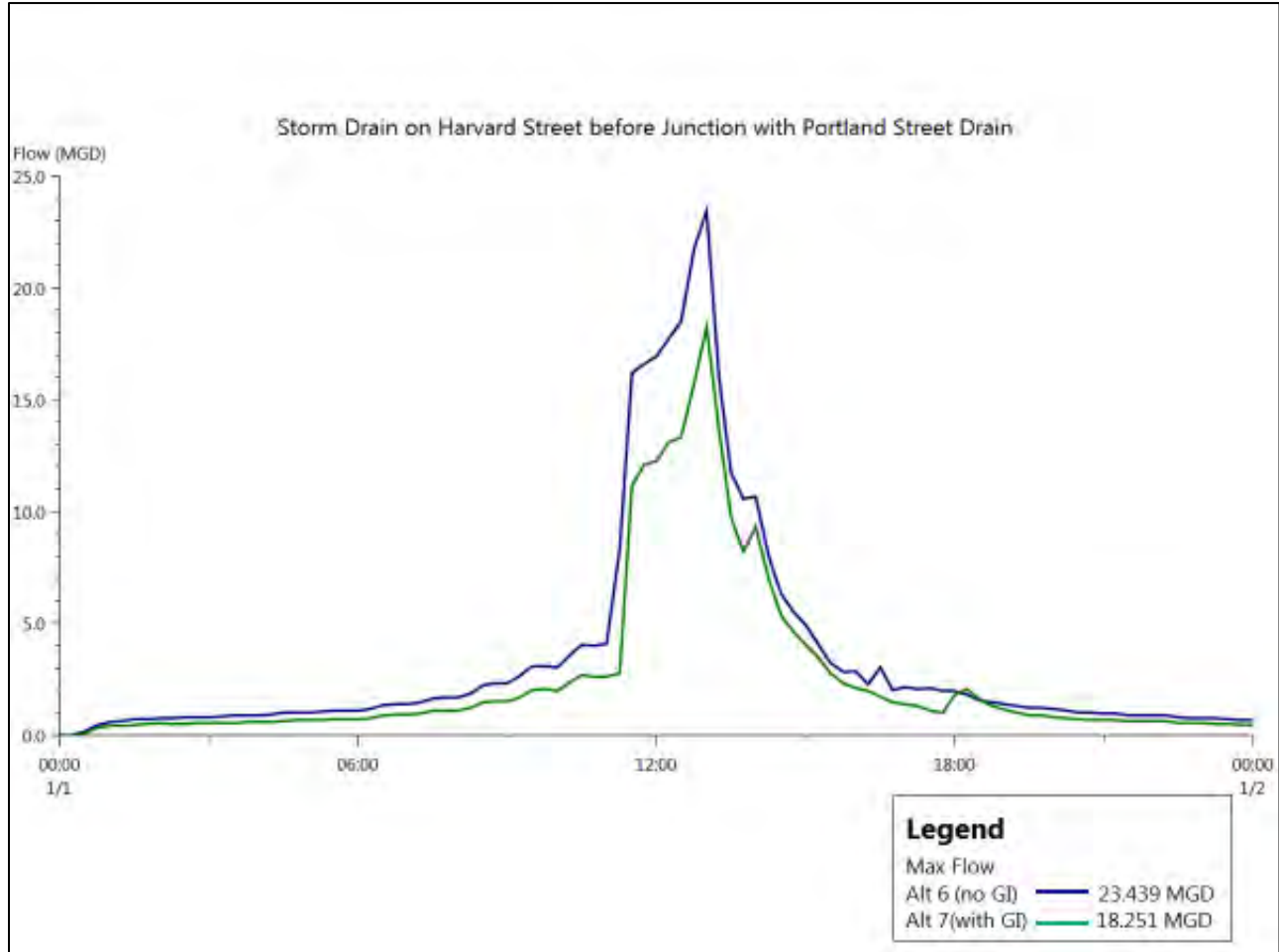
Reference: Cambridge Climate Change Preparedness and Resiliency – Flood Mitigation Alternatives for The Port Neighborhood



**Figure 12.** Flow hydrographs for Alternatives 6 and 7 at the Bishop Allen Drive drain upstream of its connection to the Main Street drain (10yr, 24-hr, 2070 event)

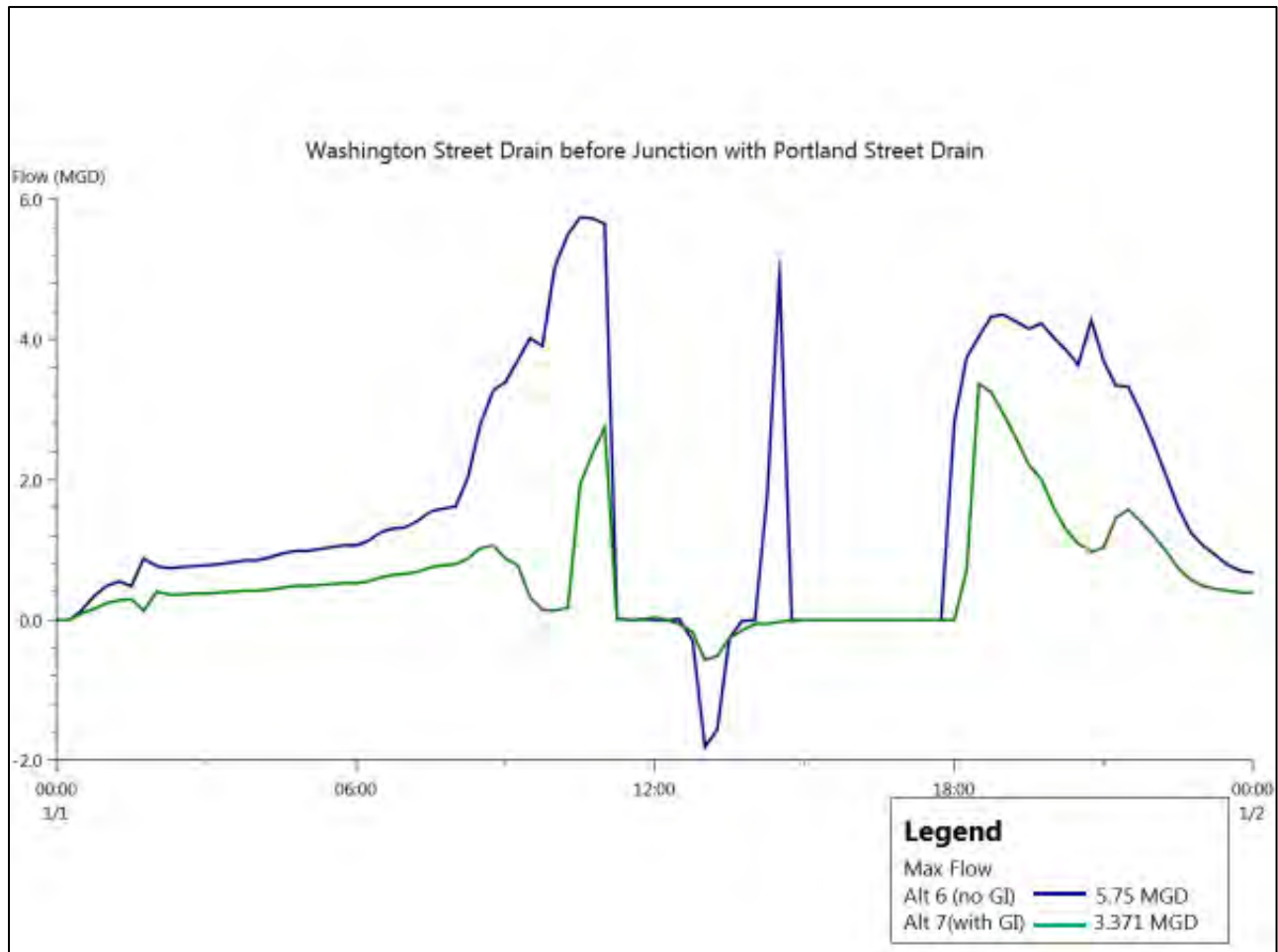


Reference: Cambridge Climate Change Preparedness and Resiliency – Flood Mitigation Alternatives for The Port Neighborhood



**Figure 13.** Flow hydrographs for Alternatives 6 and 7 at the Harvard St drain upstream of its connection to the Portland St drain (10yr, 24-hr, 2070 event)

Reference: Cambridge Climate Change Preparedness and Resiliency – Flood Mitigation Alternatives for The Port Neighborhood



**Figure 14.** Flow hydrographs for Alternatives 6 and 7 at the Washington St drain upstream of its connection to the Portland St drain (10yr, 24-hr, 2070 event)

**Conclusions:**

Implementation of gray infrastructure alternatives would help reduce inundation risk derived from changes in precipitation due to climate change as shown in Table 1. As expected, the largest reduction in flood volumes in the Port area are provided by alternatives that remove the largest amount of inflow to the combined sewer systems (i.e. alternatives 2 and 4, which remove 120 acres along Hampshire Street). Alternative 4 includes a storage tank at Donnelly Park while Alternative 2 does not.

Alternative 6 is also a highly effective solution that provides significant flooding relief to the Port area. This alternative, as described above, mostly focuses on reconfiguring the existing system by adding redundancy and accomplishes that by reusing and repurposing existing infrastructure that would already be in place in the 2020 baseline conditions. The only significant stretch of new piping under this alternative is the proposed 1,400 foot long, 36-inch storm pipe from Main Street to Mass Ave along Albany Street designed to mitigate flooding at the Portland and Albany Street intersection. Alternative 6 would protect the Port area from flooding

March 18, 2019

Kathy Watkins, Owen O’Riordan, Jim Wilcox

Page 18 of 25

Reference: Cambridge Climate Change Preparedness and Resiliency – Flood Mitigation Alternatives for The Port Neighborhood

during the 10-year, 24-hour design storm in present and 2030 climate conditions and would greatly reduce flood extent during the same storm in 2070 climate conditions with respect to 2015 and 2020 conditions (see flood maps in Appendix B). Under this alternative, flooding in the 10-year, 24-hour design storm in 2070 would only be slightly higher than the expected flood volume for the same storm in existing climate projections and with 2020 system conditions (1.56MG versus 1.24MG, respectively). Due to its high-effectiveness in flood reduction as well as the high degree of existing infrastructure reuse, Alternative 6 was deemed to be the most advantageous and feasible to implement gray infrastructure alternative.

As the alternative of choice, Alternative 6 was used as the base alternative to develop the green infrastructure implementation scenario detailed above (see Alternative 7). Implementation of GI to the degree described in Appendix A would further reduce flooding within the Port as shown in Table 1. GI could potentially reduce another 0.4 to 0.5MG of flooding beyond Alternative 6 in the 2070 time horizon. This additional reduction would mean that flooding in the Port area in 2070 would be below current climate flood estimates in 2020 system conditions (0.84MG for Alternative 7 in 2070 conditions versus 1.24MG in 2020 system conditions in current climate conditions). In a way, Alternative 7 could be thought of as an alternative that would be able to “catch up” with increasing precipitation and would certainly reduce flood risk with respect to 2015 and 2020 system conditions in future climate scenarios.

Implementation of GI infrastructure described in Alternative 7 provides significant volume and peak flow reductions at the three main system pipe outlets at Bishop Allen Drive and Main Street, Washington Street at Portland Street and Harvard Street at Portland Street. Peak flow reductions due to the assumed GI implementation scenario in the 2070 time horizon are estimated to range between 18% and 25% with respect to 2020 system conditions. Peak flow plots for Alternative 6 and 7 are shown in Figure 12 through Figure 14. These peak flow reductions also translate into flood risk reductions in the broader watershed beyond the port area (CAM017) as well as CSO flood reductions at CAM017 (not reported in this document). The proposed GI implementation scenario in Alternative 7 also provides an approximate 20% reduction in stormwater volume with respect to the no-GI scenario in Alternative 6.



## Part 2: Evaluation of Alternatives for Short Duration Storms

A large concern for the City of Cambridge is the potential adverse impacts of short, but very intense, storms. Flooding from this type of storm is mostly caused by insufficient inlet capacity or a combination of insufficient inlet and pipe conveyance capacity. In order to evaluate the potential impact of short burst storms, the model was modified to include all the catch basin inlets within the Port area. For this type of simulation, rainfall is modeled physically as falling onto the ground mesh and routed until it reaches a system inlet, it infiltrates, or ponds in a low-lying area.

The 10-year, 2-hour storm event was modeled for 2030 and 2070 climate horizons. These storms have a total rainfall depth of 2.26 and 2.56 inches, respectively. These storms were modeled using 6-minute increments with 12-minute peak rainfall intensities of 3.8 and 4.3 in/h for the 2030 and 2070 climate horizons respectively.

Four system scenarios were modeled and described below:

1. 2020 system conditions. This system condition is the same as the 2020 gray infrastructure conditions alternatives but includes catch basin inlets within the Port area.
2. Alternative SD-1: This alternative is equivalent to gray infrastructure Alternative 6 but includes all the existing catch basin inlets in the Port area.
3. Alternative SD-2: This is the same as alternative SD-1 but assumes the catch basin inlet capacity has been doubled across the entire Port neighborhood (i.e. single grate catch basins now become double grate catch basins and catch basin laterals have been upsized to 15 inches in diameter).
4. Alternative SD-3: This is the same as Alternative SD-2 but assumes the Clement Morgan Park stormwater tank pump station has additional pumping capacity (an additional 10MGD for a total of 20MGD of pump capacity). The point of connection of the new 10MGD pump to the south Mass Ave drain was assumed to be near the intersection with Windsor Street as opposed to the end-of-line manhole between Douglas and Columbia streets on Mass Ave.

Peak flood volumes in the Port area generated by the short duration storms are provided in Table 2.

Peak flood depth maps for the same events are provided in Appendix C.

**Table 2. Peak Flood Volumes in the Port Area under 2hr Storm**

Volume (MG)	2020 Conditions	SD-1	SD-2	SD-3
10yr, 2hr - 2030	5.8	4.0	3.8	3.8
10yr, 2hr - 2070	7.0	5.5	5.3	5.1

As shown in Table 2, flooding generated by short duration storms can be as significant or greater than flooding generated by the 24-hour events. Some reasons that may explain why volumes in Table 2 (2-hour storms) are larger than those in Table 1 (24-hour storms) are listed below.

- The modeling methodology used with the 24-hour storms is different than the methodology used for the 2-hour events. In the 24-hour events, modeling is performed using traditional catchment rainfall-runoff relationships and flows in excess of the piping system conveyance capacity are then routed on the ground surface at the points of exit (usually at the lowest points). On the other hand, the methodology used for the 2-hour storms consists of applying a “rainfall on the mesh” approach. With this approach

Reference: Cambridge Climate Change Preparedness and Resiliency – Flood Mitigation Alternatives for The Port Neighborhood

rainfall falls on the terrain mesh so the entirety of the ground surface model gets wet, which may lead to higher computed flood volumes. In order to minimize this issue, only volumes at locations with flood depths equal to or greater than 1.2 inches (0.1 feet) were computed and reported in 2.

- The storms used to evaluate the impact of short duration storms have very large peak intensities, which result in flooding due to insufficient inlet capacity in some locations, especially under 2020 conditions and Alternative SD-1. However, most of the flooding is still caused because these very high intensities generate very large, rapid-moving peak flows that exceed the pipe system’s capacity even under Alternative SD-3. For example, the incoming peak flows into Morgan Tank exceed 30MGD, well above the total pump capacity of 20MGD under Alternative SD-3. Table 3 summarizes the rainfall intensities of the 2030 and 2070 events.

**Table 3. 10-year, 2-hour storm average peak intensities for different time intervals**

<b>Time Interval (min)</b>	<b>2030 Time Horizon</b>	<b>2070 Time Horizon</b>
<b>6-min</b>	3.8	4.3
<b>12-min</b>	3.8	4.3
<b>30-min</b>	2.6	2.9
<b>1-hour</b>	1.8	2.1
<b>2-hours</b>	1.1	1.3

Based on the results shown above, the system conveyance system is not configured to provide flood relief for short but very intense storms. Since the pipe system becomes overwhelmed and generates spills, it is impossible to determine which portion of the flooding is generated by insufficient inlet capacity and which is generated by lack of pipe conveyance capacity as both are beyond their design ranges. To determine effective improvements for the surface inlet system, it is recommended that inlet capacity be evaluated using a less intense storm that is within the level of service range of the sub-surface pipe network.

---

## Appendix A

### GI Implementation Summary Tables



**Table A.1. Green Infrastructure Treated Area per Subcatchment (excludes resilient blocks)**

Model subcatchment	Subcatchment Area (sq-ft)	Subcatchment Area Treated (%)	Total BMP Treated Area					BMP Footprint Area					BMP Tributary Area				
			Bio-retention (sq ft)	Porous Pavement (sq ft)	Green Roof (sq ft)	Leaching CB (sq ft)	Tree Box (sq ft)	Bio-retention (sq ft)	Porous Pavement (sq ft)	Green Roof (sq ft)	Leaching CB (sq ft)	Tree Box (sq ft)	Bio-retention (sq ft)	Porous Pavement (sq ft)	Green Roof (sq ft)	Leaching CB (sq ft)	Tree Box (sq ft)
181 MAss Ave	44866.8	1.16%	0.0	0.0	13526.7	0.0	0.0	0.0	0.0	13006.4	0.0	0.0	0.0	0.0	520.3	0.0	0.0
610 MainSt	88862.4	3.92%	0.0	0.0	31553.3	1454.9	1075.2	0.0	0.0	30339.7	88.0	168.0	0.0	0.0	1213.6	1367.0	907.2
935040	66124.1	4.47%	0.0	0.0	17679.4	1454.9	1075.2	0.0	0.0	16999.4	88.0	168.0	0.0	0.0	680.0	1367.0	907.2
CAM103	49745.5	0.01%	0.0	0.0	142.6	0.0	0.0	0.0	0.0	137.1	0.0	0.0	0.0	0.0	5.5	0.0	0.0
CAM112	131899.7	0.22%	0.0	0.0	7557.6	0.0	0.0	0.0	0.0	7267.0	0.0	0.0	0.0	0.0	290.7	0.0	0.0
CAM113	243544.0	1.03%	0.0	0.0	6152.2	1454.9	1075.2	0.0	0.0	5915.6	88.0	168.0	0.0	0.0	236.6	1367.0	907.2
CAM114	126803.2	0.06%	0.0	0.0	2040.5	0.0	0.0	0.0	0.0	1962.0	0.0	0.0	0.0	0.0	78.5	0.0	0.0
CAM118	248204.9	0.22%	0.0	211.3	9997.3	0.0	0.0	0.0	56.7	9612.8	0.0	0.0	0.0	154.7	384.5	0.0	0.0
CAM120	396091.1	5.62%	0.0	0.0	46696.5	13094.4	9676.8	0.0	0.0	44900.4	791.7	1512.0	0.0	0.0	1796.0	12302.7	8164.8
CAM121	349699.7	0.33%	0.0	0.0	0.0	727.5	537.6	0.0	0.0	0.0	44.0	84.0	0.0	0.0	0.0	683.5	453.6
CAM122	788784.5	0.77%	0.0	0.0	40403.0	2909.9	2150.4	0.0	0.0	38849.0	175.9	336.0	0.0	0.0	1554.0	2733.9	1814.4
CAM123	390254.0	2.99%	0.0	12528.1	5940.1	1454.9	1075.2	0.0	3358.8	5711.7	88.0	168.0	0.0	9169.4	228.5	1367.0	907.2
CAM124	73834.2	76.29%	59144.2	4933.3	0.0	0.0	0.0	6428.7	1322.6	0.0	0.0	0.0	52715.4	3610.7	0.0	0.0	0.0
CAM24	318815.6	1.89%	0.0	425.9	1112.1	3637.3	2688.0	0.0	114.2	1069.4	219.9	420.0	0.0	311.7	42.8	3417.4	2268.0
CAM25	435512.9	10.99%	22015.4	32356.4	0.0	2909.9	2150.4	2393.0	8674.6	0.0	175.9	336.0	19622.4	23681.7	0.0	2733.9	1814.4
CAM26_1	233046.0	3.62%	5094.8	653.4	0.0	2182.4	1612.8	553.8	175.2	0.0	131.9	252.0	4541.0	478.2	0.0	2050.5	1360.8
CAM26_2	233046.0	0.98%	0.0	0.0	0.0	1454.9	1075.2	0.0	0.0	0.0	88.0	168.0	0.0	0.0	0.0	1367.0	907.2
CAM27	139958.3	4.27%	0.0	0.0	7632.3	3637.3	2688.0	0.0	0.0	7338.8	219.9	420.0	0.0	0.0	293.6	3417.4	2268.0
CAM28	121271.0	4.99%	4556.4	2342.3	7038.5	0.0	0.0	495.3	628.0	6767.8	0.0	0.0	4061.1	1714.3	270.7	0.0	0.0
CAM29	377491.0	5.58%	21304.6	784.3	9778.9	727.5	537.6	2315.7	210.3	9402.8	44.0	84.0	18988.9	574.1	376.1	683.5	453.6
CAM30	327701.9	29.06%	101015.6	6086.4	19215.1	0.0	0.0	10980.0	1631.7	18476.1	0.0	0.0	90035.6	4454.6	739.0	0.0	0.0
CAM31_1	269070.1	40.88%	85456.3	46206.0	0.0	0.0	0.0	9288.7	12387.7	0.0	0.0	0.0	76167.6	33818.3	0.0	0.0	0.0
CAM31_2	269070.1	18.89%	54297.4	3317.5	0.0	0.0	0.0	5901.9	889.4	0.0	0.0	0.0	48395.5	2428.1	0.0	0.0	0.0
CAM32	539185.7	24.46%	133503.4	11268.4	2848.4	2909.9	2150.4	14511.2	3021.0	2738.9	175.9	336.0	118992.1	8247.4	109.6	2733.9	1814.4
CAM67	501593.4	15.48%	67378.1	20641.5	5123.5	1454.9	1075.2	7323.7	5533.9	4926.5	88.0	168.0	60054.4	15107.6	197.1	1367.0	907.2
CAM78	159865.2	24.56%	9976.1	38278.4	2233.8	1454.9	1075.2	1084.4	10262.3	2147.9	88.0	168.0	8891.8	28016.1	85.9	1367.0	907.2
CAM79	127282.3	48.03%	58698.2	12050.7	49.8	0.0	0.0	6380.2	3230.8	47.9	0.0	0.0	52317.9	8820.0	1.9	0.0	0.0
CAM80	118831.7	14.22%	3158.0	11384.2	1808.4	3637.3	2688.0	343.3	3052.1	1738.9	219.9	420.0	2814.7	8332.2	69.6	3417.4	2268.0
CAM81	242193.6	1.06%	0.0	0.0	37268.6	727.5	537.6	0.0	0.0	35835.2	44.0	84.0	0.0	0.0	1433.4	683.5	453.6
CAM82	135645.8	3.27%	0.0	1038.4	6720.2	2182.4	1612.8	0.0	278.4	6461.8	131.9	252.0	0.0	760.0	258.5	2050.5	1360.8
CAM84	223419.2	2.33%	0.0	0.0	17074.9	2909.9	2150.4	0.0	0.0	16418.1	175.9	336.0	0.0	0.0	656.7	2733.9	1814.4
CAM98	43211.5	2.72%	0.0	0.0	1010.5	727.5	537.6	0.0	0.0	971.6	44.0	84.0	0.0	0.0	38.9	683.5	453.6
<b>TOTAL</b>	<b>7814925.4</b>	<b>10.26%</b>	<b>625598.3</b>	<b>204506.5</b>	<b>300604.2</b>	<b>53105.1</b>	<b>39244.8</b>	<b>67999.8</b>	<b>54827.5</b>	<b>289042.5</b>	<b>3210.7</b>	<b>6132.0</b>	<b>557598.5</b>	<b>149679.1</b>	<b>11561.7</b>	<b>49894.4</b>	<b>33112.8</b>

Table A.2. Green Infrastructure Parameter Values Used in the Modeling Process

Control type	Surface Layer			Pavement Layer					Soil Layer							Storage Layer				Drainage Mat		
	Berm height (in)	Vegetation volume fraction	Surface roughness (Manning's n)	Pavement thickness (in)	Pavement void ratio	Impervious surface fraction	Permeability (in/hr)	Pavement clogging factor	Soil class	Soil thickness (in)	Soil porosity	Field capacity	Wilting point	Conductivity (in/hr)	Suction head (in)	Storage thickness (in)	Storage void ratio	Seepage rate (in/hr)	Storage clogging factor	Mat thickness (in)	Mat void fraction	Mat roughness (Manning's n)
Bio-retention cell	6	0.1	0.08	N/A	N/A	N/A	N/A	N/A	Sandy	12	0.437	0.062	0.024	4.74	1.93	24	0.2	0.4	0	N/A	N/A	N/A
Green roof	0	0.1	0.025	N/A	N/A	N/A	N/A	N/A	Sandy	4	0.437	0.062	0.024	4.74	1.93	N/A	N/A	N/A	N/A	0.08	0.5	0.1
Tree Box	0	0.1	0.025	N/A	N/A	N/A	N/A	N/A	Sandy	36	0.437	0.062	0.024	4.74	1.93	6	0.32	0.4	0	N/A	N/A	N/A
Leaching CB	0	N/A	N/A	N/A	N/A	N/A	N/A	N/A	N/A	N/A	N/A	N/A	N/A	N/A	N/A	6	0.4	0.4	0	N/A	N/A	N/A
Permeable pavement	0	N/A	0.02	4	0.2	0	10	0	Sandy	20	0.437	0.3	0.15	4.74	1.93	14	0.4	0.4	0	N/A	N/A	N/A
Blue roof*	4.5	N/A	0.02	N/A	N/A	N/A	N/A	N/A	N/A	N/A	N/A	N/A	N/A	N/A	N/A	N/A	N/A	N/A	N/A	N/A	N/A	N/A

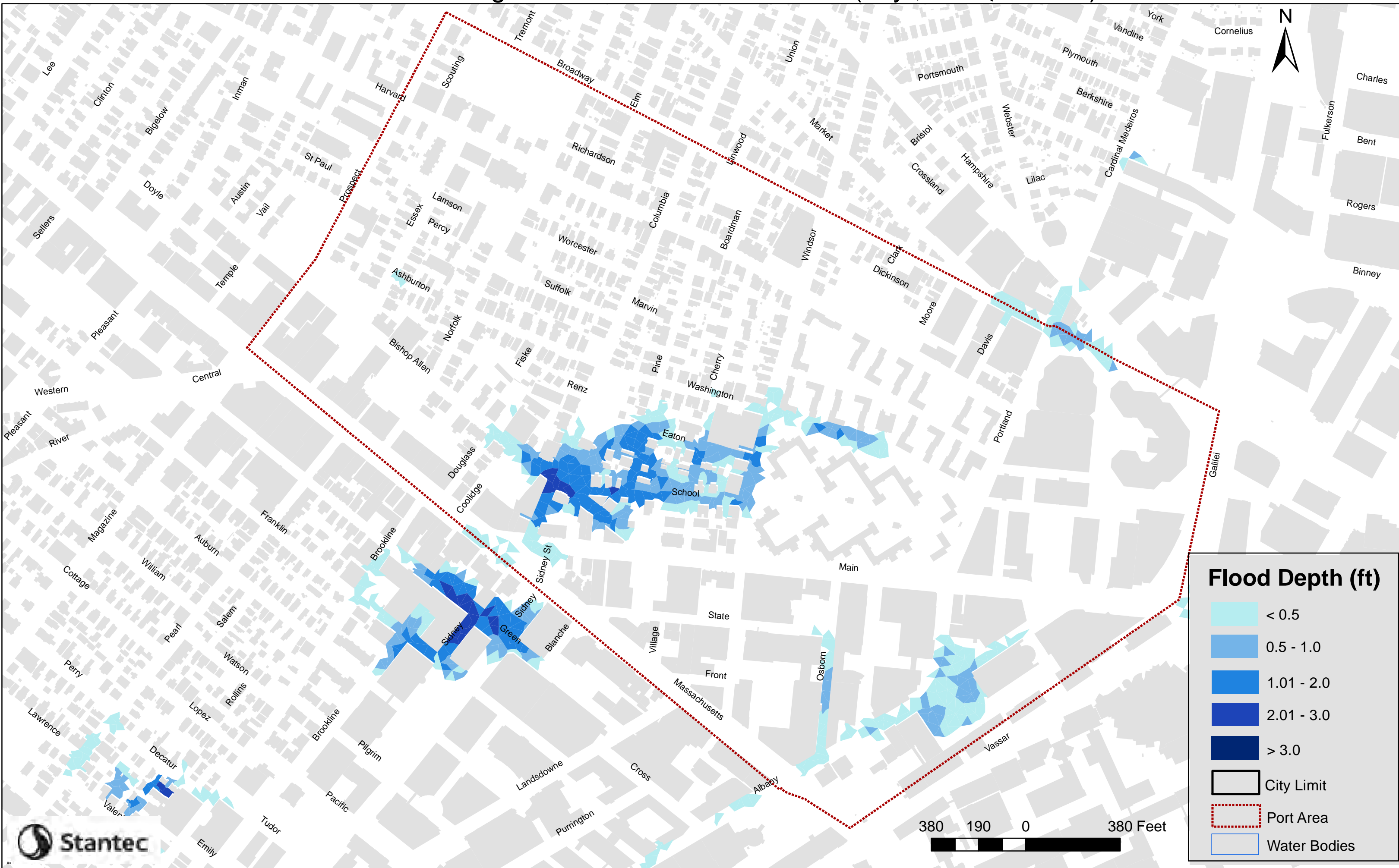
\*Blue roofs refer to building roofs designed to capture rainfall and slowly release it back to the pipe system via a throttled outlet or underdrain

Note: Underdrains have only been assumed blue and green roofs

## **Appendix B**

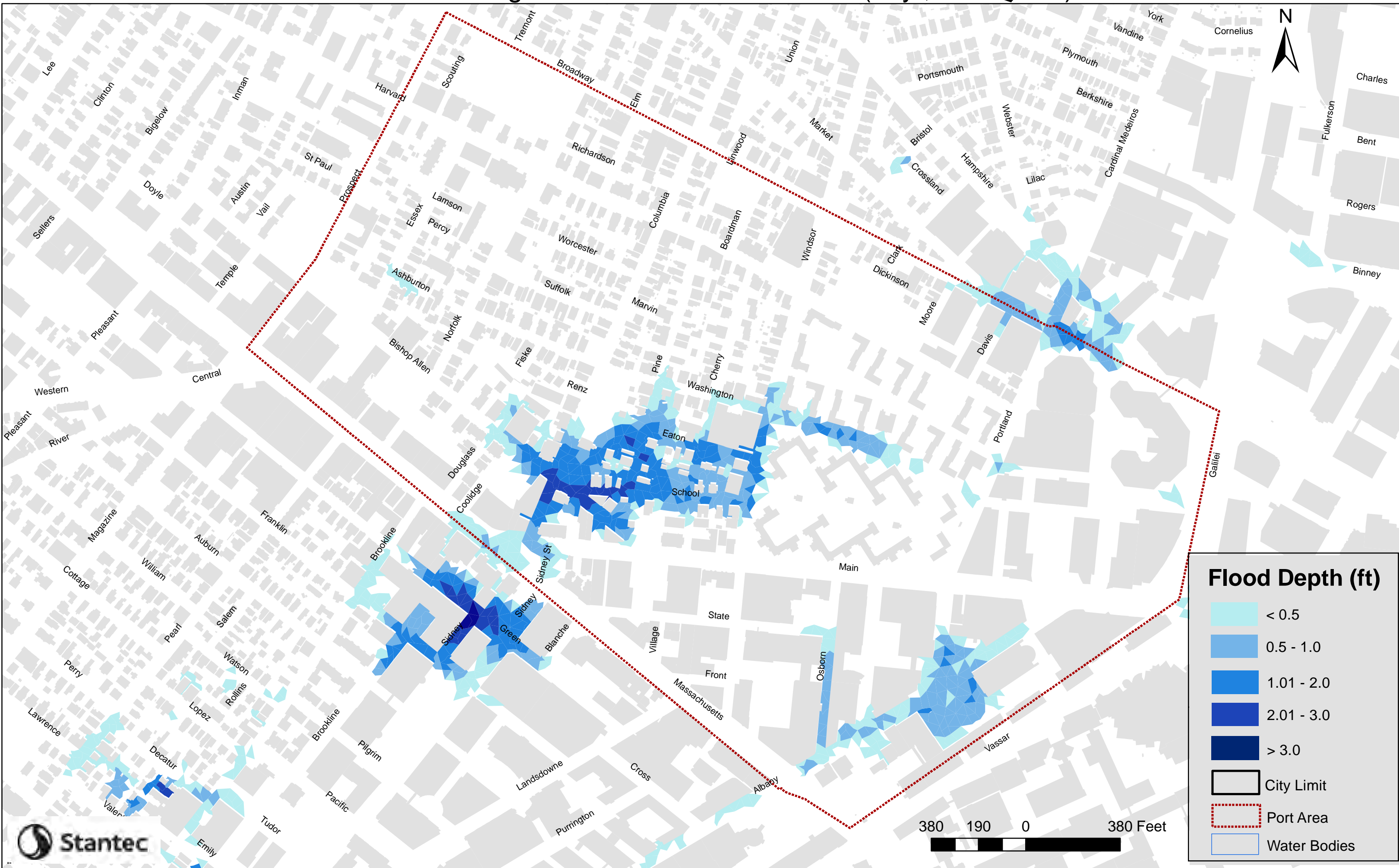
### **10-year, 24-hour Storms Peak Flood Depth Maps**

# InfoWorks ICM Integrated Model 2015 Condition (10yr, 24hr, Present)

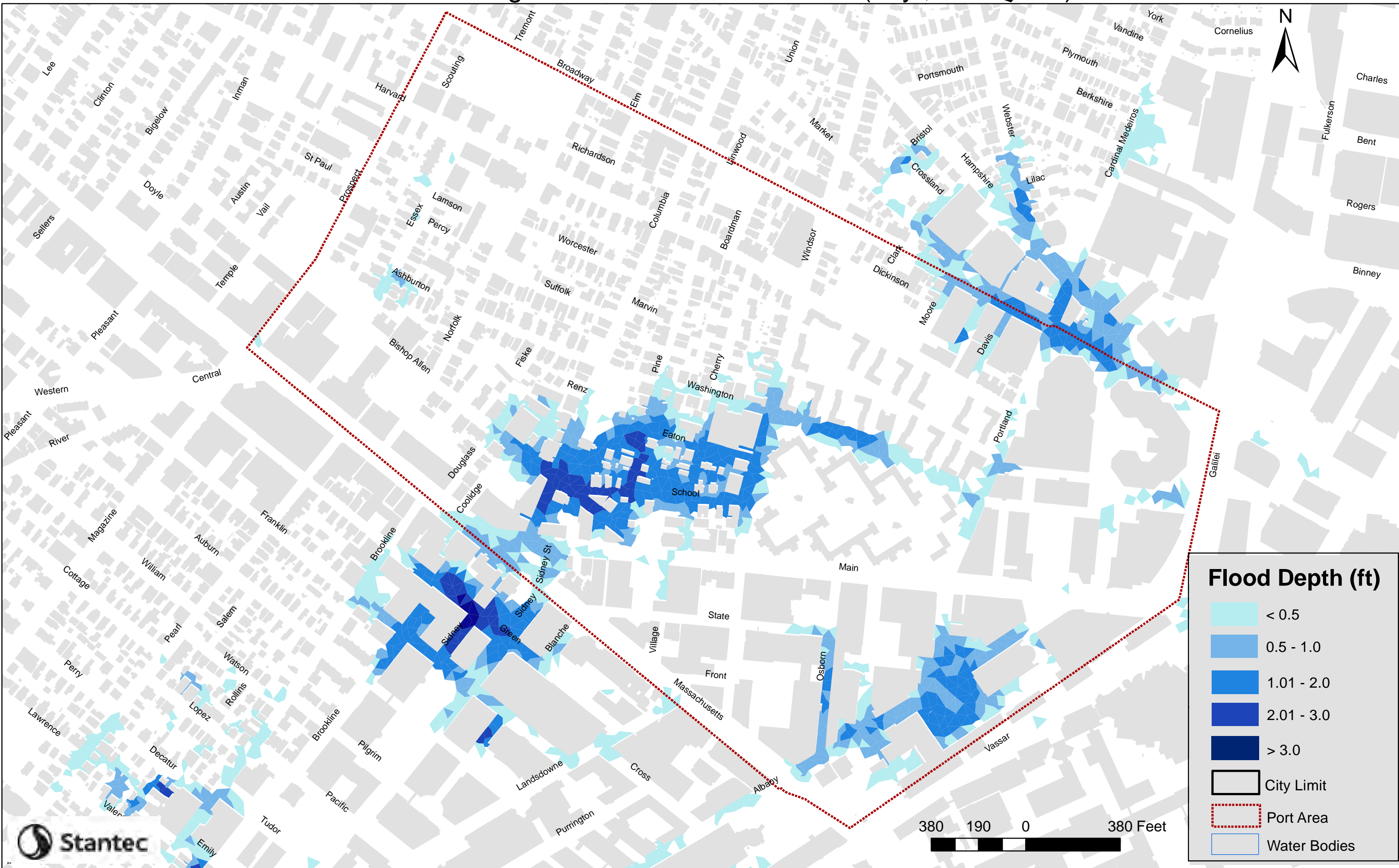




# InfoWorks ICM Integrated Model 2015 Condition(10yr, 24hr-2030)

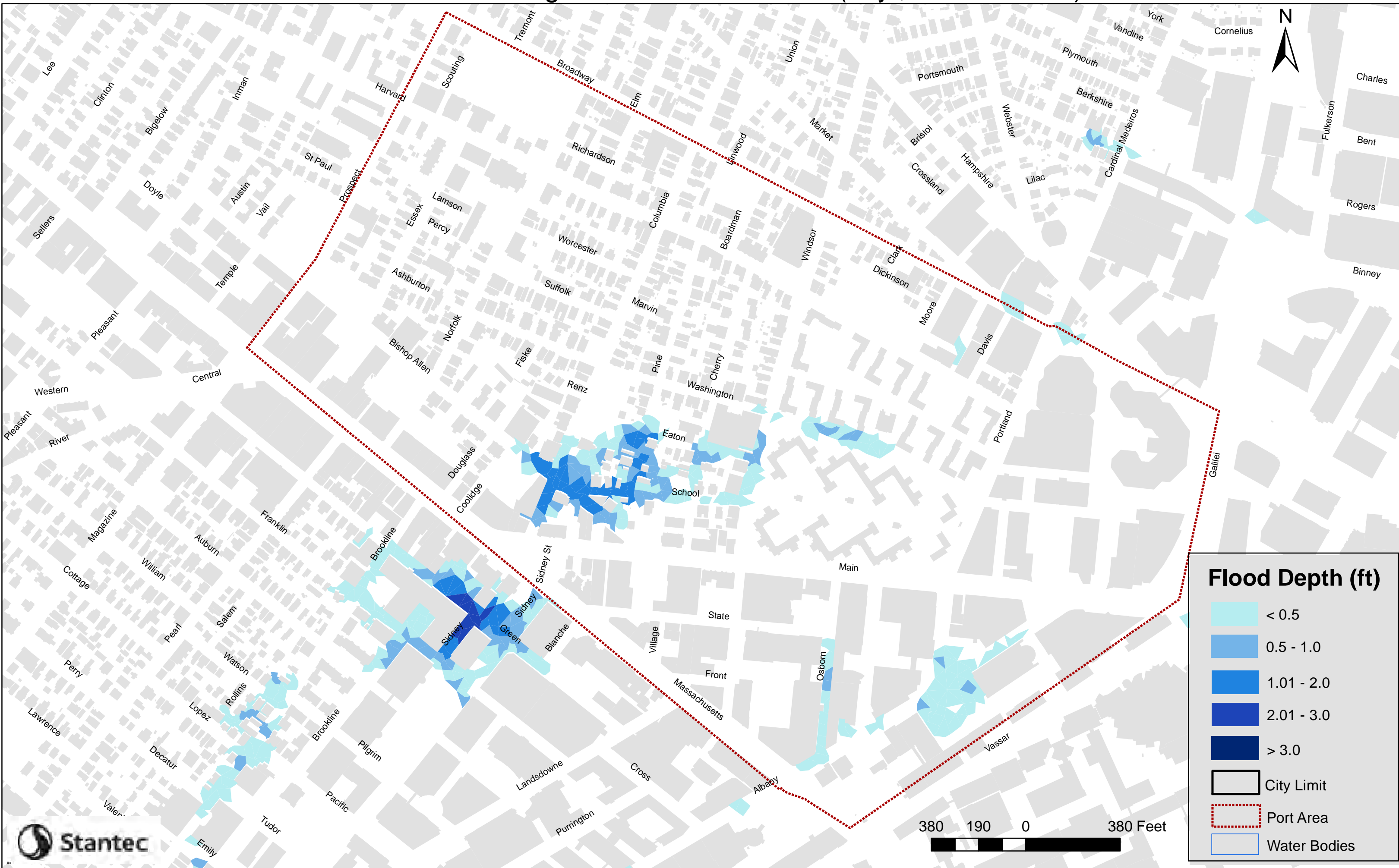


# InfoWorks ICM Integrated Model 2015 Condition(10yr, 24hr-2070)





# InfoWorks ICM Integrated 2020 Conditions (10yr, 24hr-Present)



380 190 0 380 Feet

**Flood Depth (ft)**

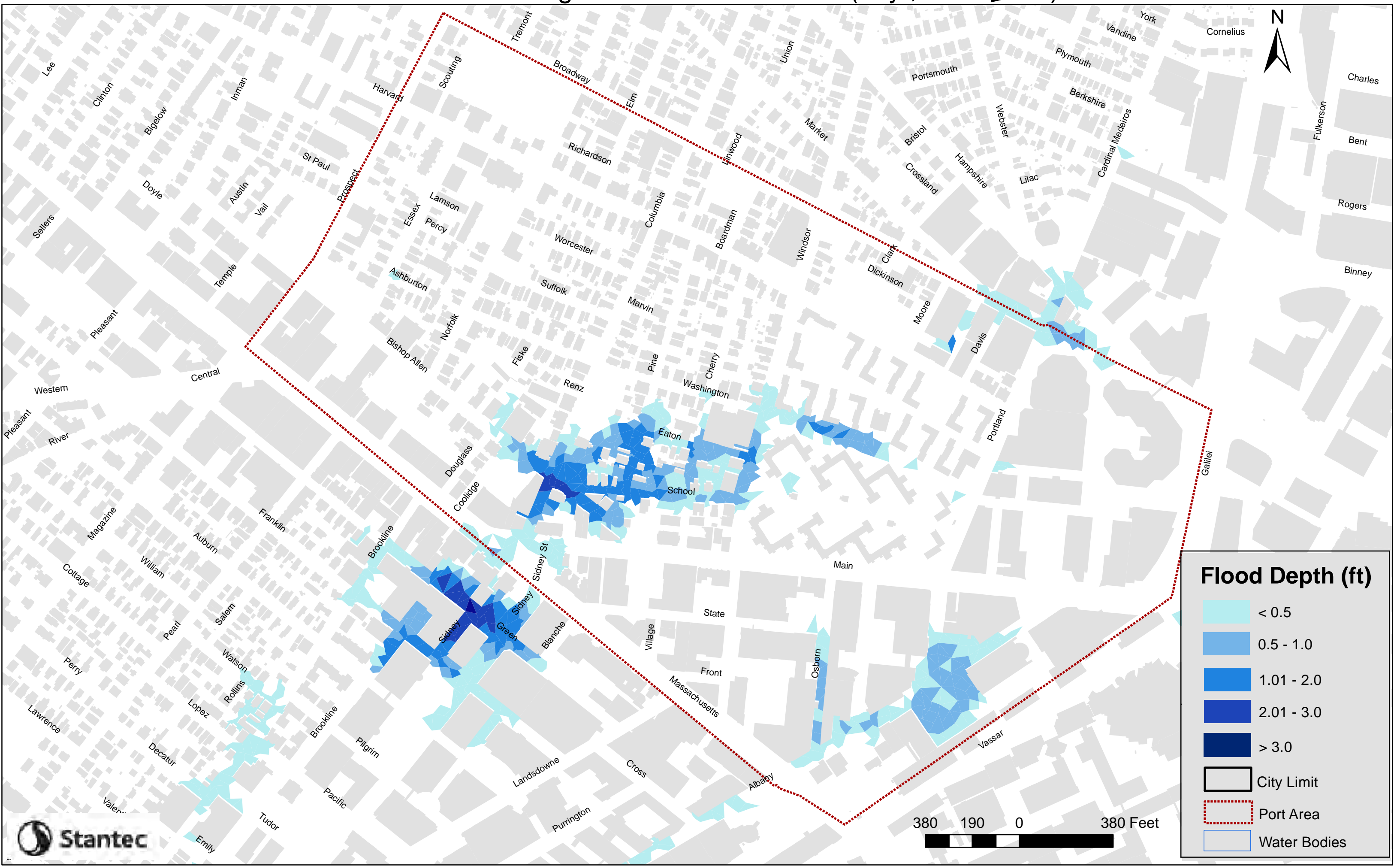
- < 0.5
- 0.5 - 1.0
- 1.01 - 2.0
- 2.01 - 3.0
- > 3.0

City Limit

Port Area

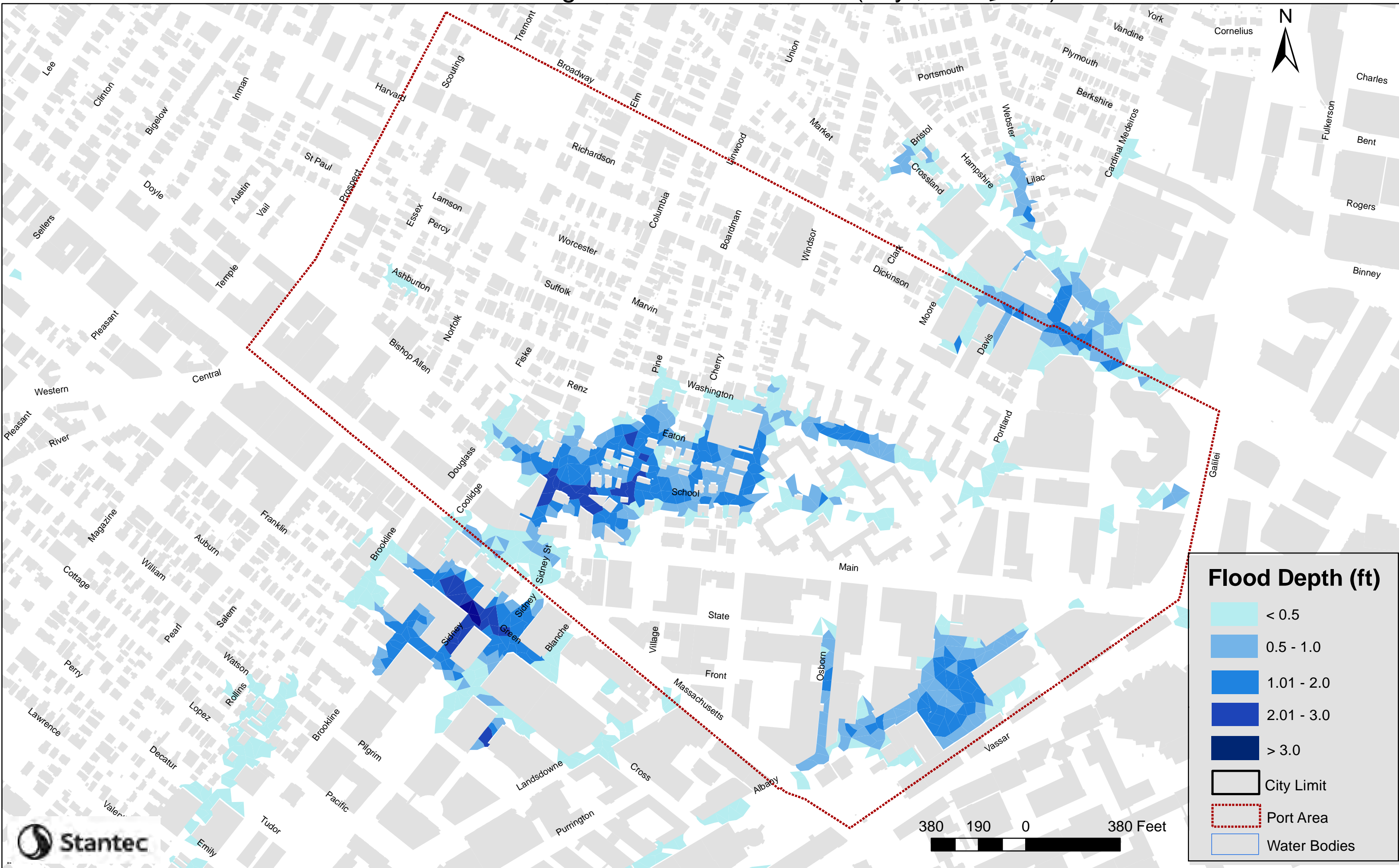
Water Bodies

# InfoWorks ICM Integrated 2020 Conditions (10yr, 24hr-2030)

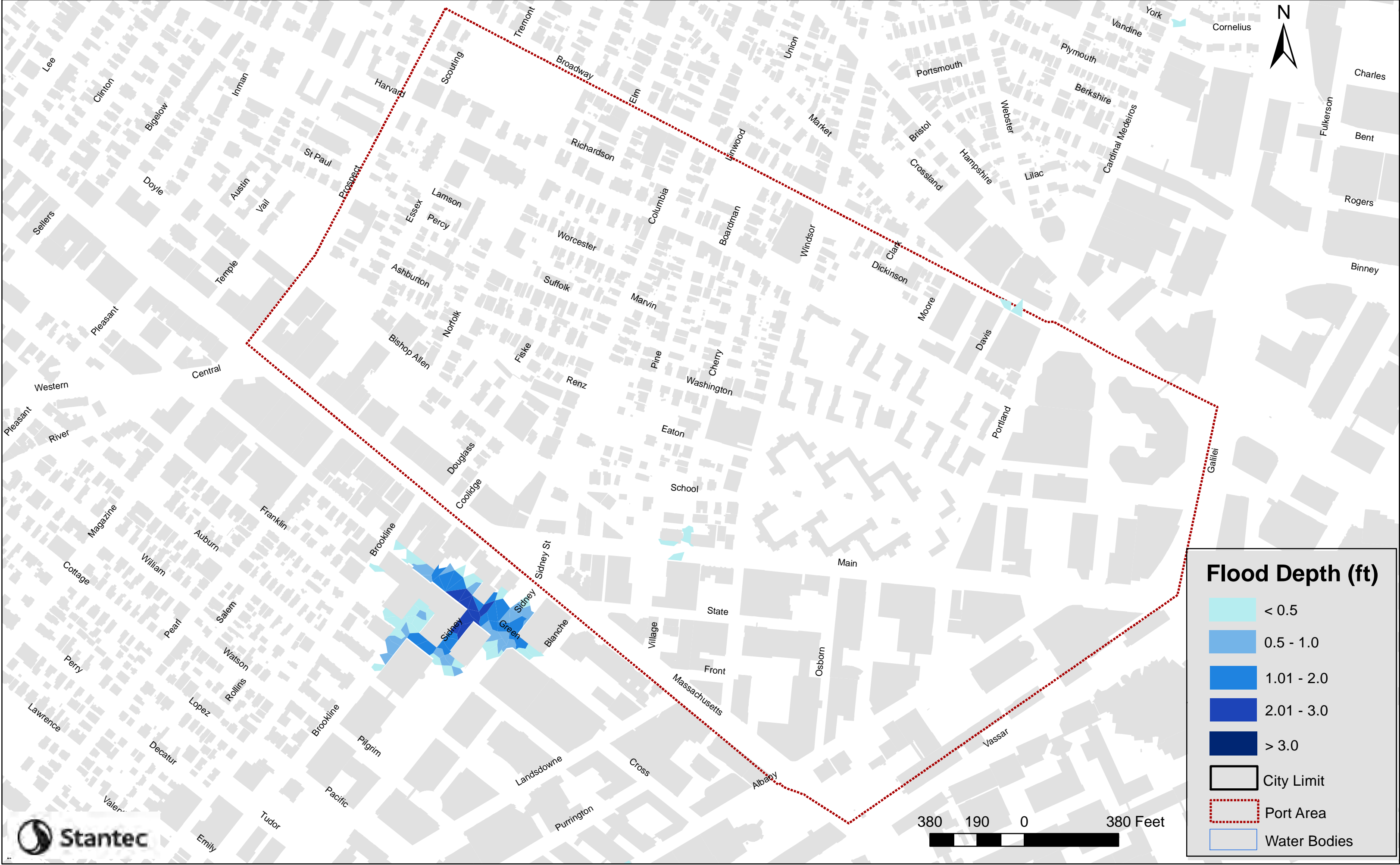




# InfoWorks ICM Integrated 2020 Conditions (10yr,24hr-2070)



# InfoWorks ICM Integrated Model Alternative 6 (10yr, 24hr-Present)



**Flood Depth (ft)**

- < 0.5
- 0.5 - 1.0
- 1.01 - 2.0
- 2.01 - 3.0
- > 3.0
- City Limit
- Port Area
- Water Bodies

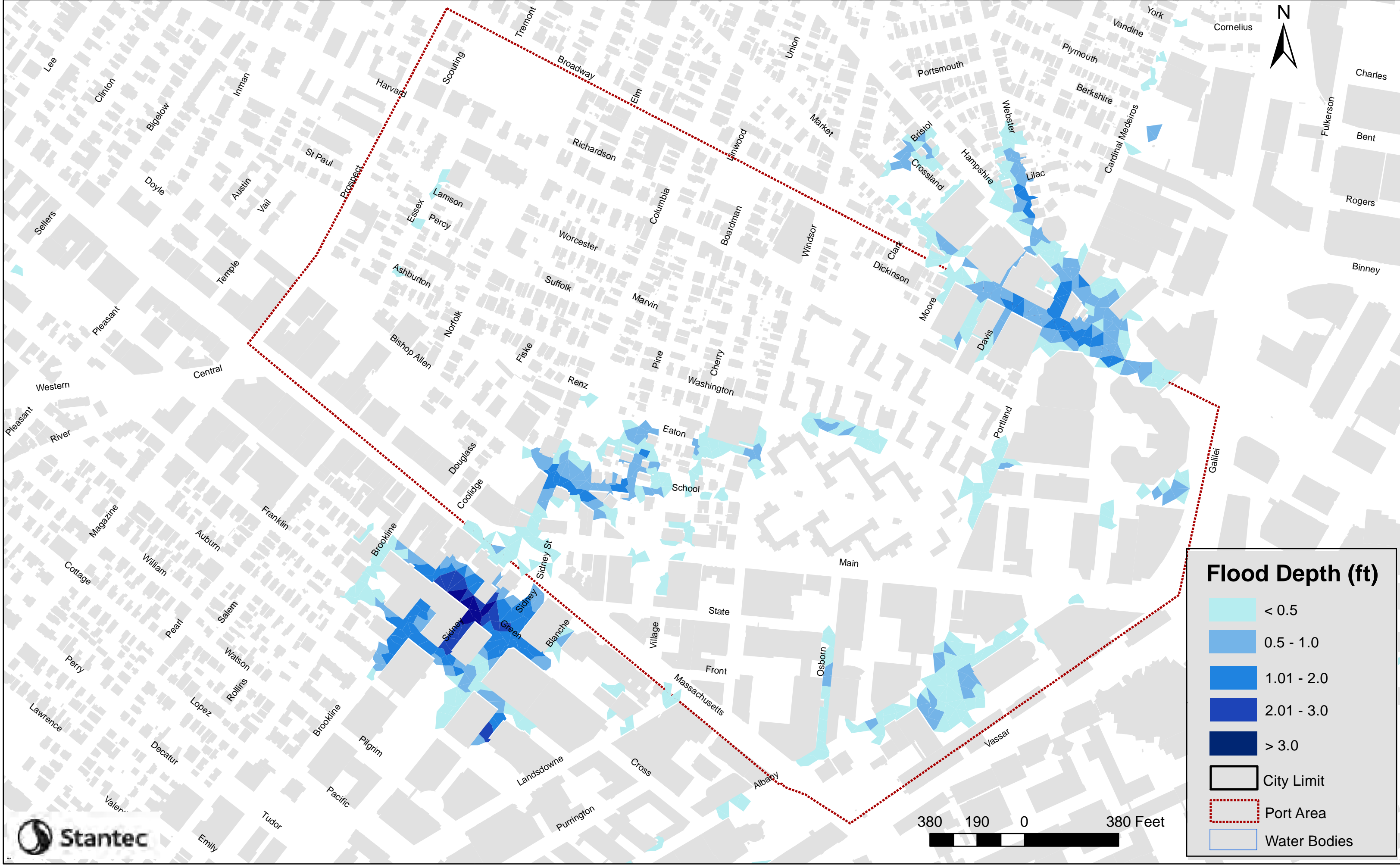
380 190 0 380 Feet







# InfoWorks ICM Integrated Model Alternative 6 (10yr, 24hr-2070)



**Flood Depth (ft)**

- < 0.5
- 0.5 - 1.0
- 1.01 - 2.0
- 2.01 - 3.0
- > 3.0

City Limit

Port Area

Water Bodies



380 190 0 380 Feet

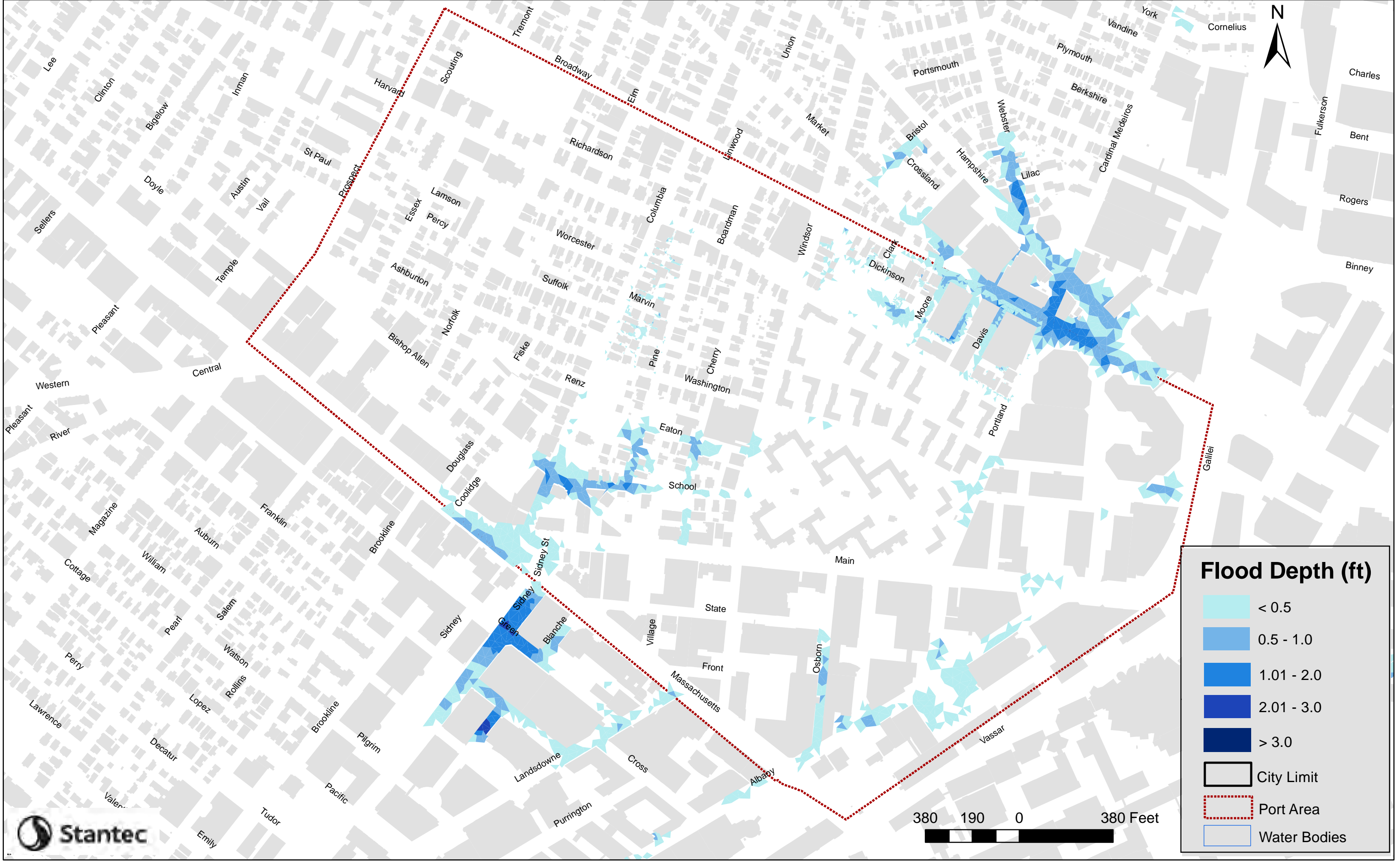








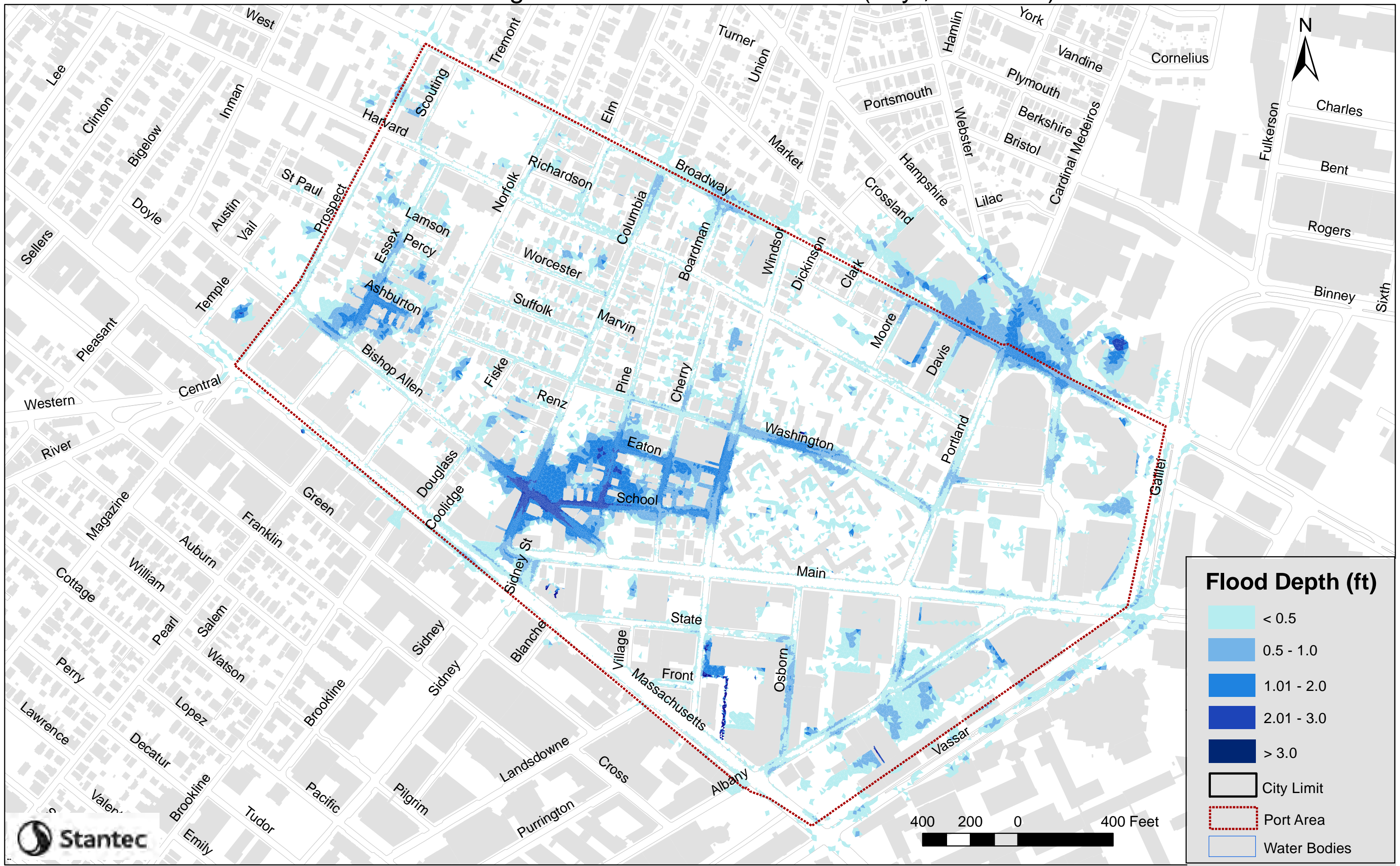
# InfoWorks ICM Integrated Model Alternative 7 (10yr, 24hr-2070)



**Appendix C****10-year, 2-hour Storms Peak Flood Depth Maps**



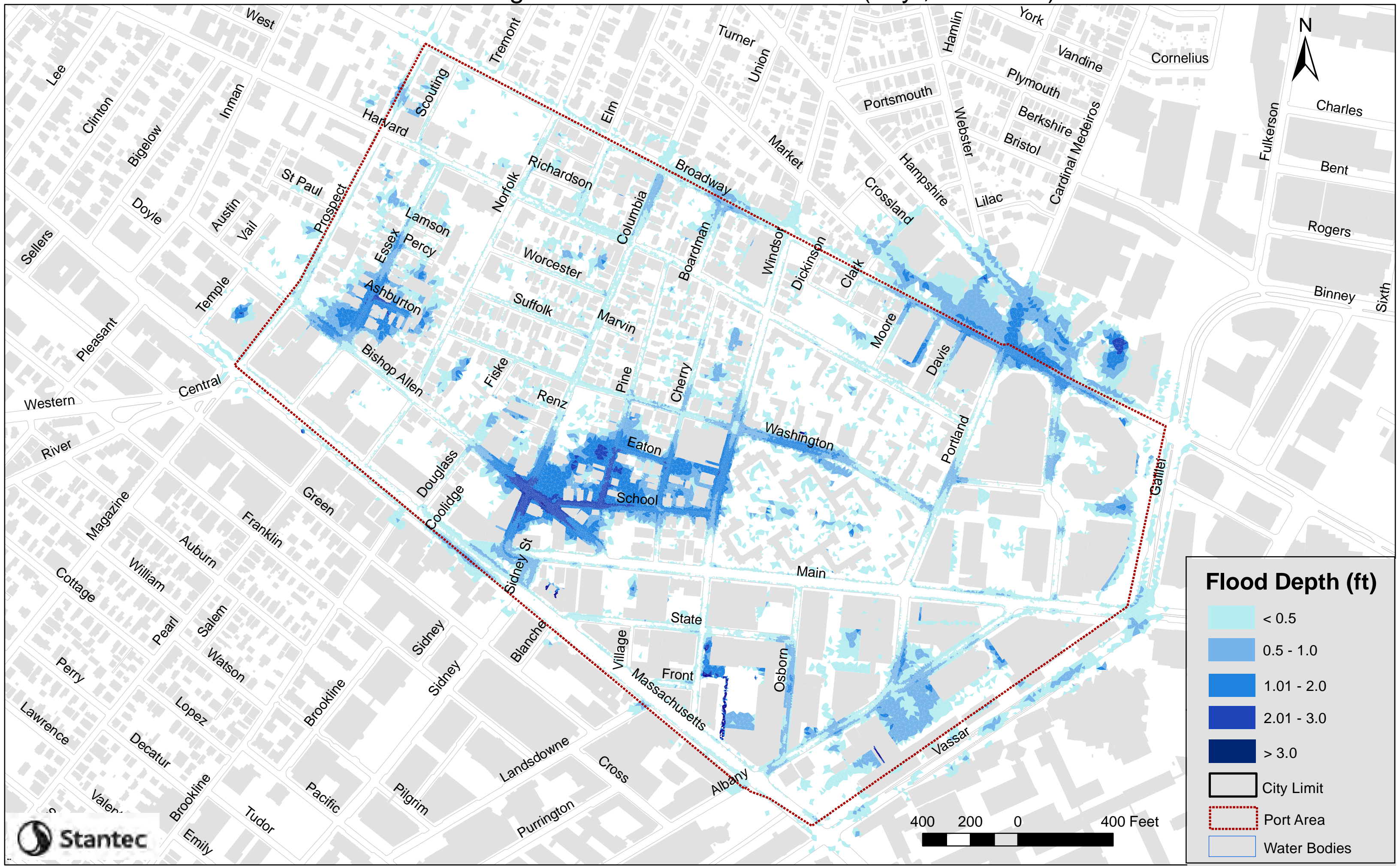
# InfoWorks ICM Integrated Model 2020 Condition(10yr, 2hr-2030)



400 200 0 400 Feet

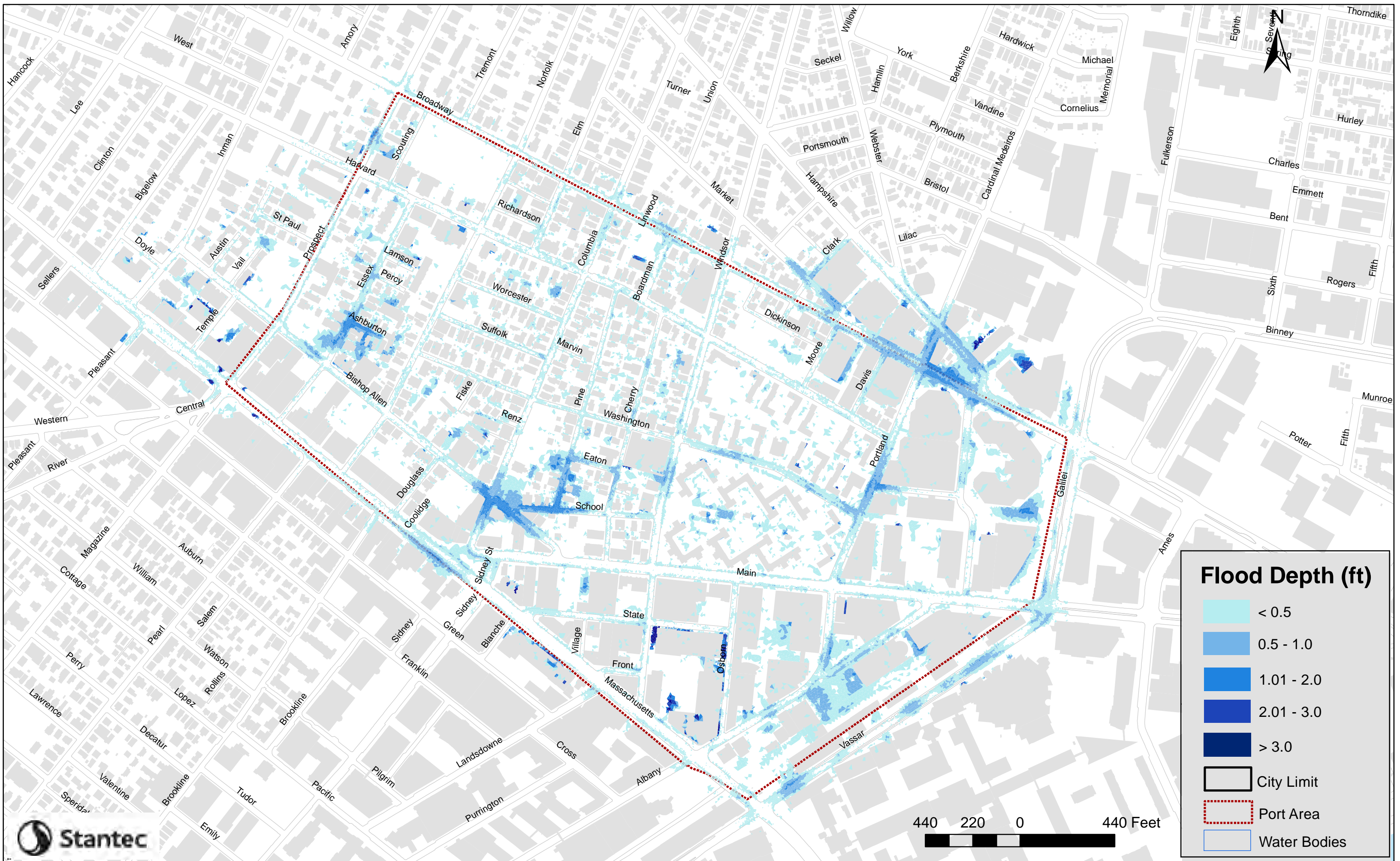


# InfoWorks ICM Integrated Model 2020 Condition(10yr, 2hr-2070)





# InfoWorks ICM Integrated SD-1 under 10y2hr 2030 storm



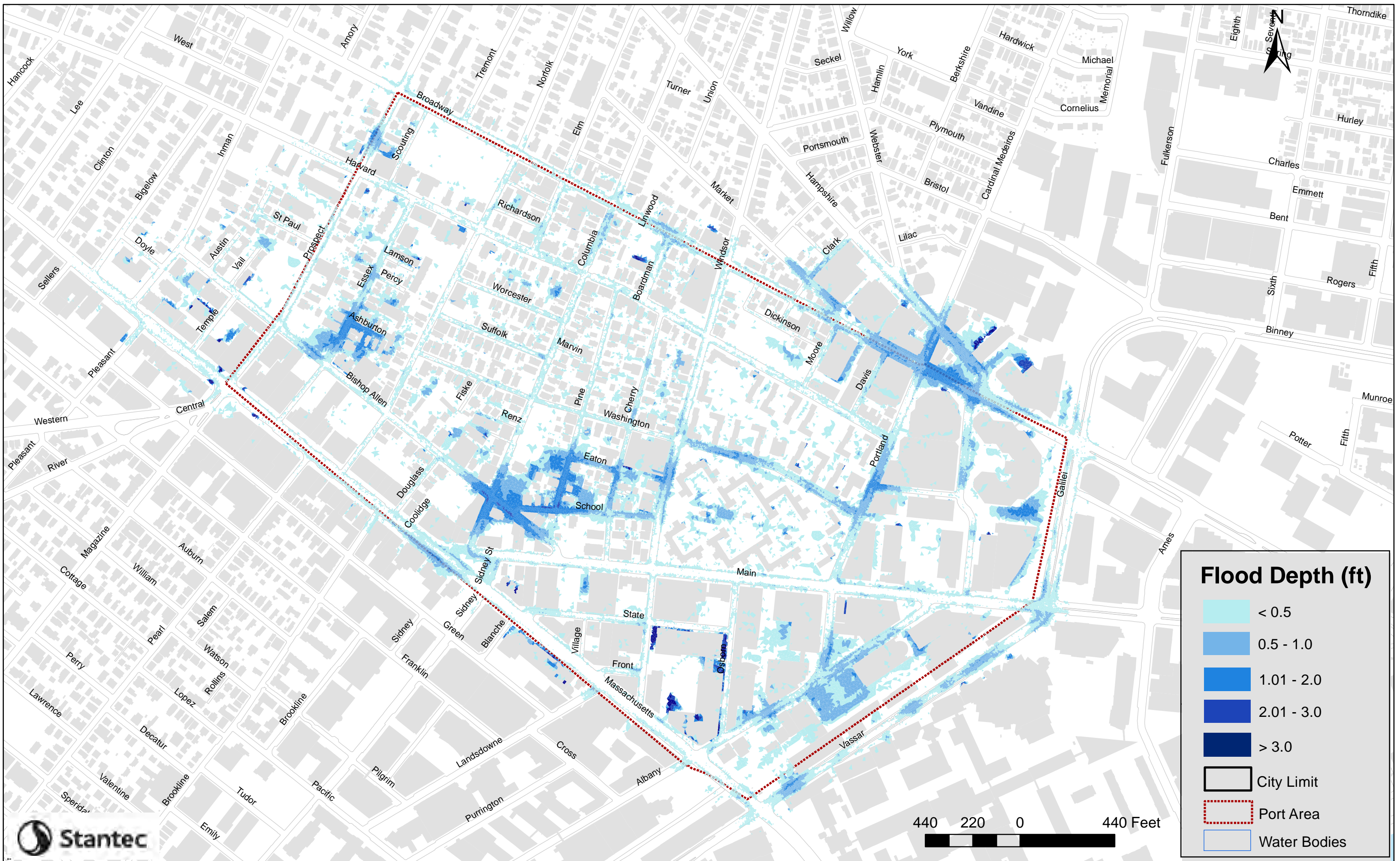
### Flood Depth (ft)

	< 0.5
	0.5 - 1.0
	1.01 - 2.0
	2.01 - 3.0
	> 3.0
	City Limit
	Port Area
	Water Bodies





# InfoWorks ICM Integrated SD-1 under 10y2hr 2070 storm



### Flood Depth (ft)

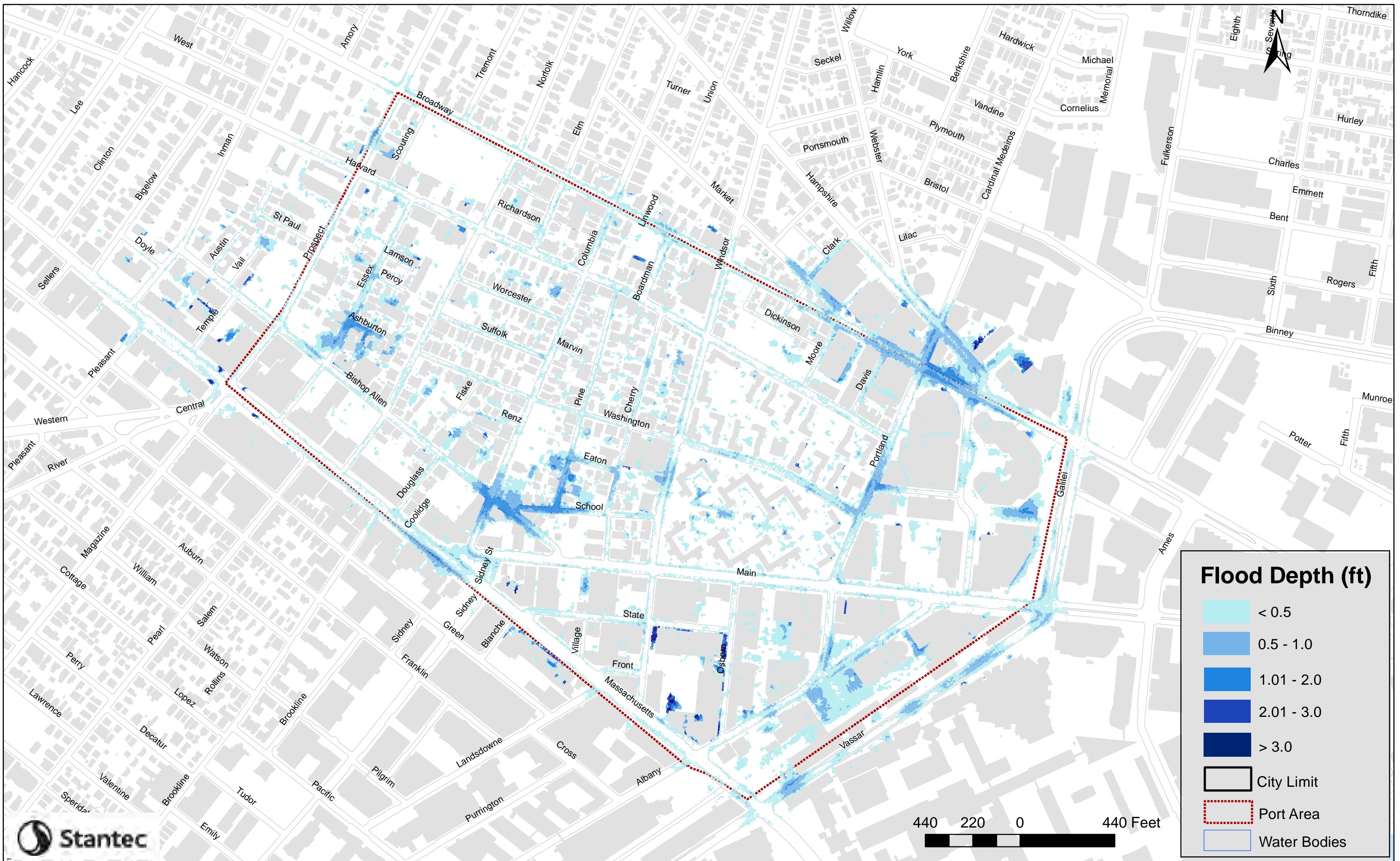
	< 0.5
	0.5 - 1.0
	1.01 - 2.0
	2.01 - 3.0
	> 3.0
	City Limit
	Port Area
	Water Bodies



440 220 0 440 Feet



# InfoWorks ICM Integrated SD-2 under 10y2hr 2030 storm



### Flood Depth (ft)

	< 0.5
	0.5 - 1.0
	1.01 - 2.0
	2.01 - 3.0
	> 3.0
	City Limit
	Port Area
	Water Bodies



440 220 0 440 Feet

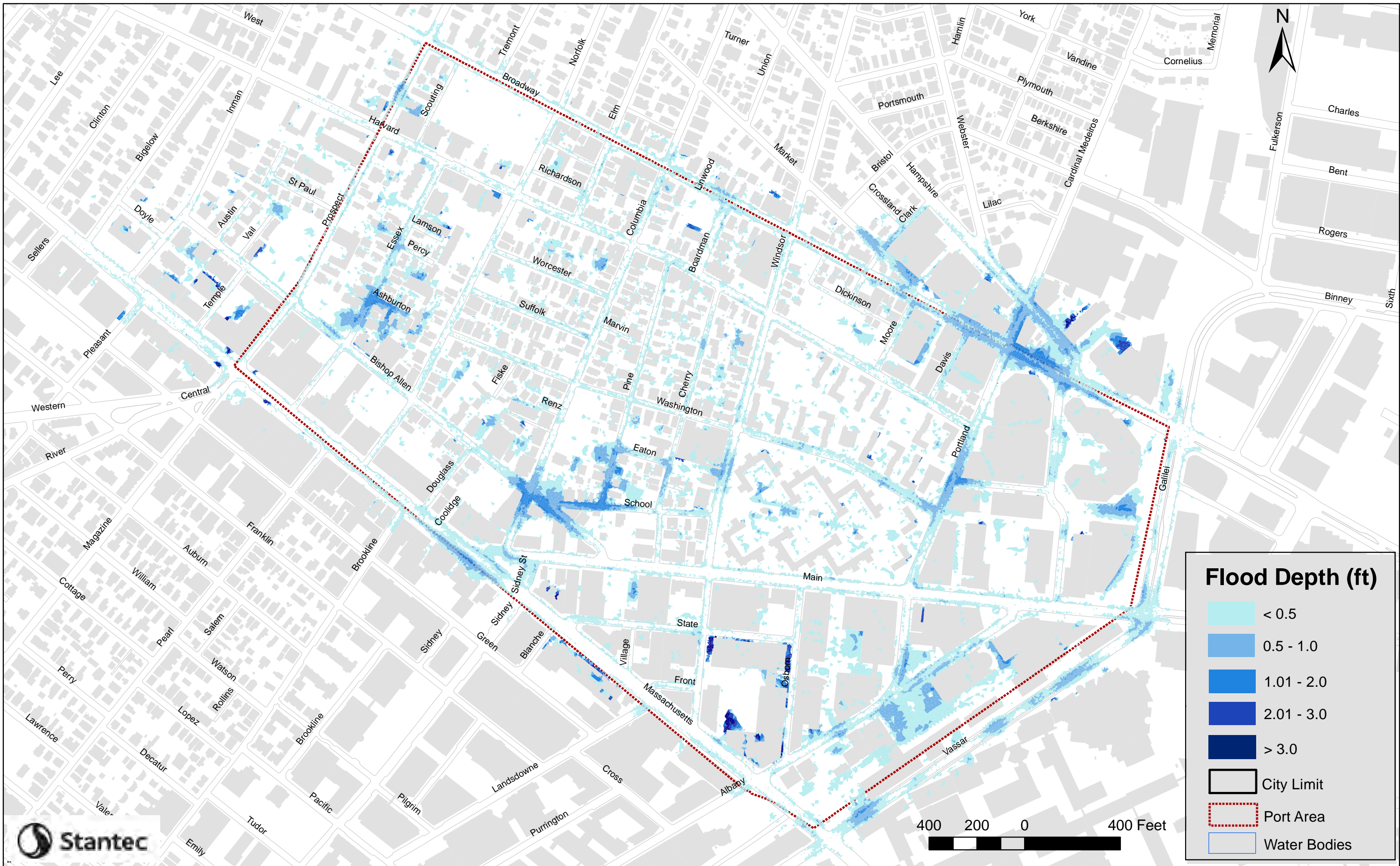


# InfoWorks ICM Integrated SD-2 under 10y2hr 2070 storm





# InfoWorks ICM Integrated SD-3 under 10y2hr 2030 storm





# InfoWorks ICM Integrated SD-3 under 10y2hr 2070 storm

