



CAMBRIDGE HISTORICAL COMMISSION

831 Massachusetts Avenue, 2nd Fl., Cambridge, Massachusetts 02139
Telephone: 617 349 4683 TTY: 617 349 6112
E-mail: histcomm@cambridgema.gov URL: www.cambridgema.gov/Historic

APPLICATION FOR CERTIFICATE

1. The undersigned hereby applies to the Cambridge Historical Commission for a Certificate of (check one box): Appropriateness, Nonapplicability, or Hardship, in accordance with Chapter 40C of the Massachusetts General Laws and/or Chapter 2.78 of the Municipal Code.

2. Address of property: , Cambridge, Massachusetts

3. Describe the proposed alteration(s), construction or demolition in the space provided below:
(An additional page can be attached, if necessary).

The objective of this project is to install a pair of granite piers with black metal lamps, and a black bifold iron gate, at the entrance to the driveway of 27 Craigie Street. The granite piers are intended to be similar in design to similar piers in the neighborhood. The iron gate is designed as a continuation of an existing historic iron fence. Overall, the intent of the project is to beautify the entrance to the property and provide light for both pedestrians and drivers entering the property.

I certify that the information contained herein is true and accurate to the best of my knowledge and belief. The undersigned also attests that he/she has read the statements printed on the reverse.

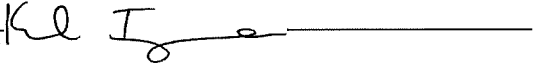
Name of Property Owner of Record: <input type="text" value="27 Craigie Street Nominee Trust (Karl Iagnemma, Trustee)"/>	
Mailing Address: <input type="text" value="27 Craigie Street, Cambridge MA, 02478"/>	
Telephone/Fax: <input type="text" value="617 955 9893"/>	E-mail: <input type="text" value="karliagnemma@gmail.com"/>
Signature of Property Owner of Record:  (Required field; application will not be considered complete without)	
Name of proponent, if not record owner: <input type="text"/>	
Mailing Address: <input type="text"/>	
Telephone/Fax: <input type="text"/>	E-mail: <input type="text"/>
(for office use only):	
Date Application Received: _____	Case Number: <u>5183</u> Hearing Date: <u>9/12/24</u>
Type of Certificate Issued: _____	Date Issued: _____

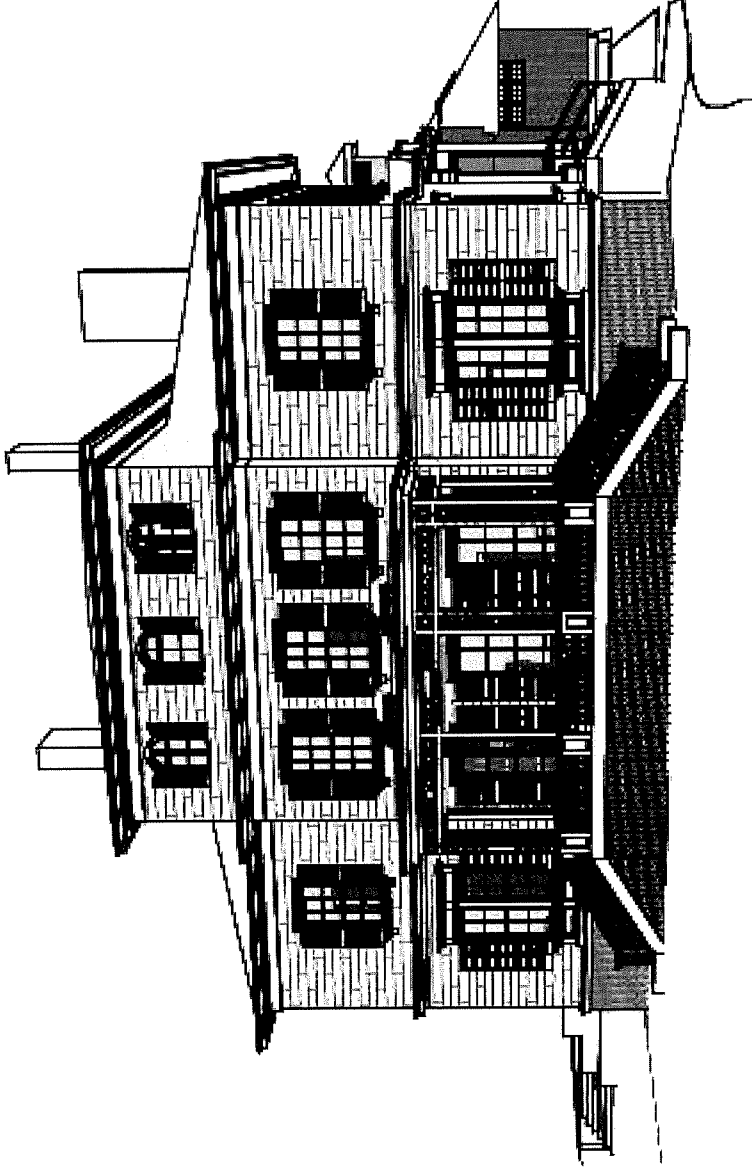

27 Craigie Street

Proposal to add granite piers, lamps, and a bifold iron gate
at the driveway entrance

September 5, 2024

Plan of Existing Site

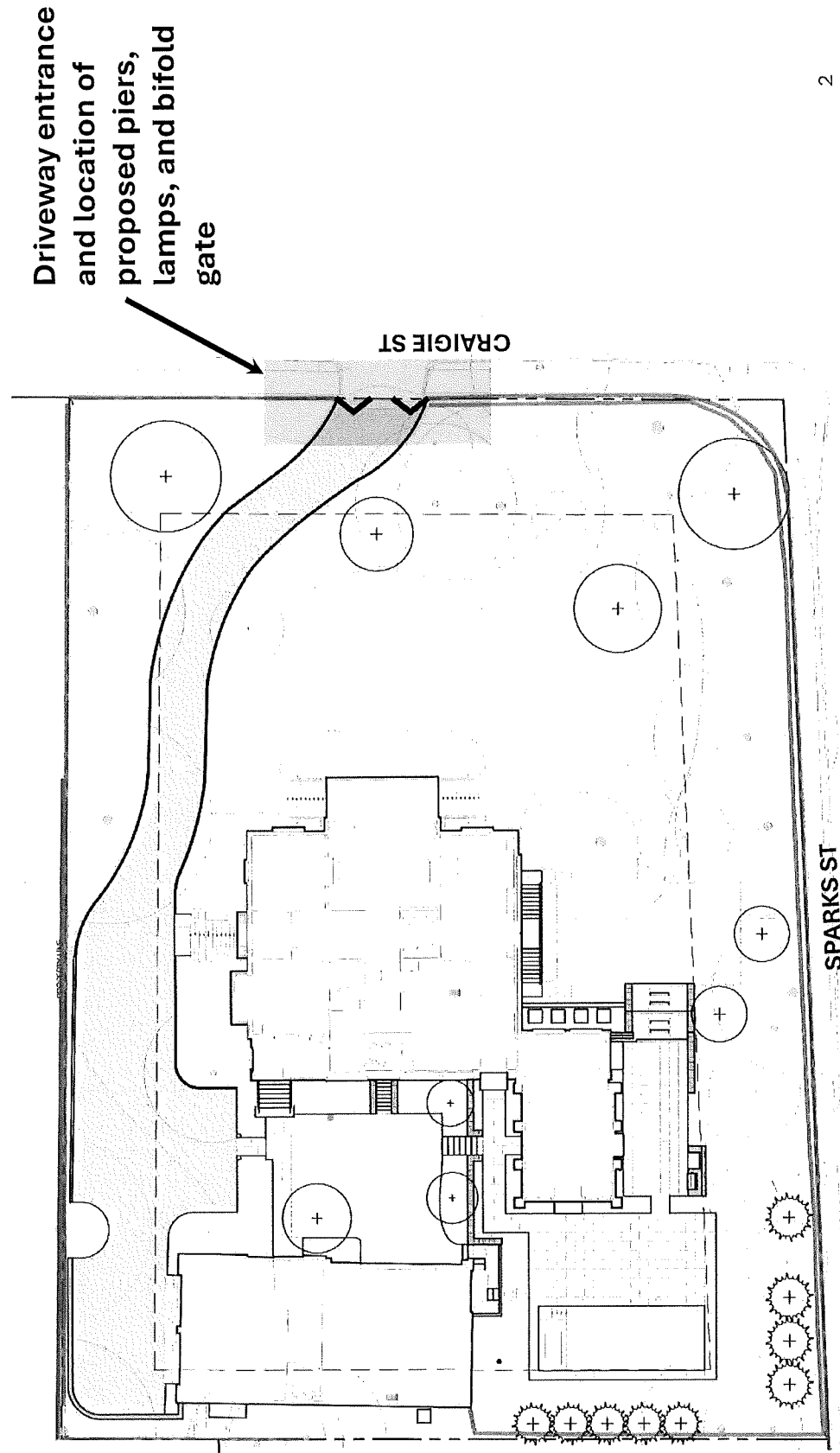

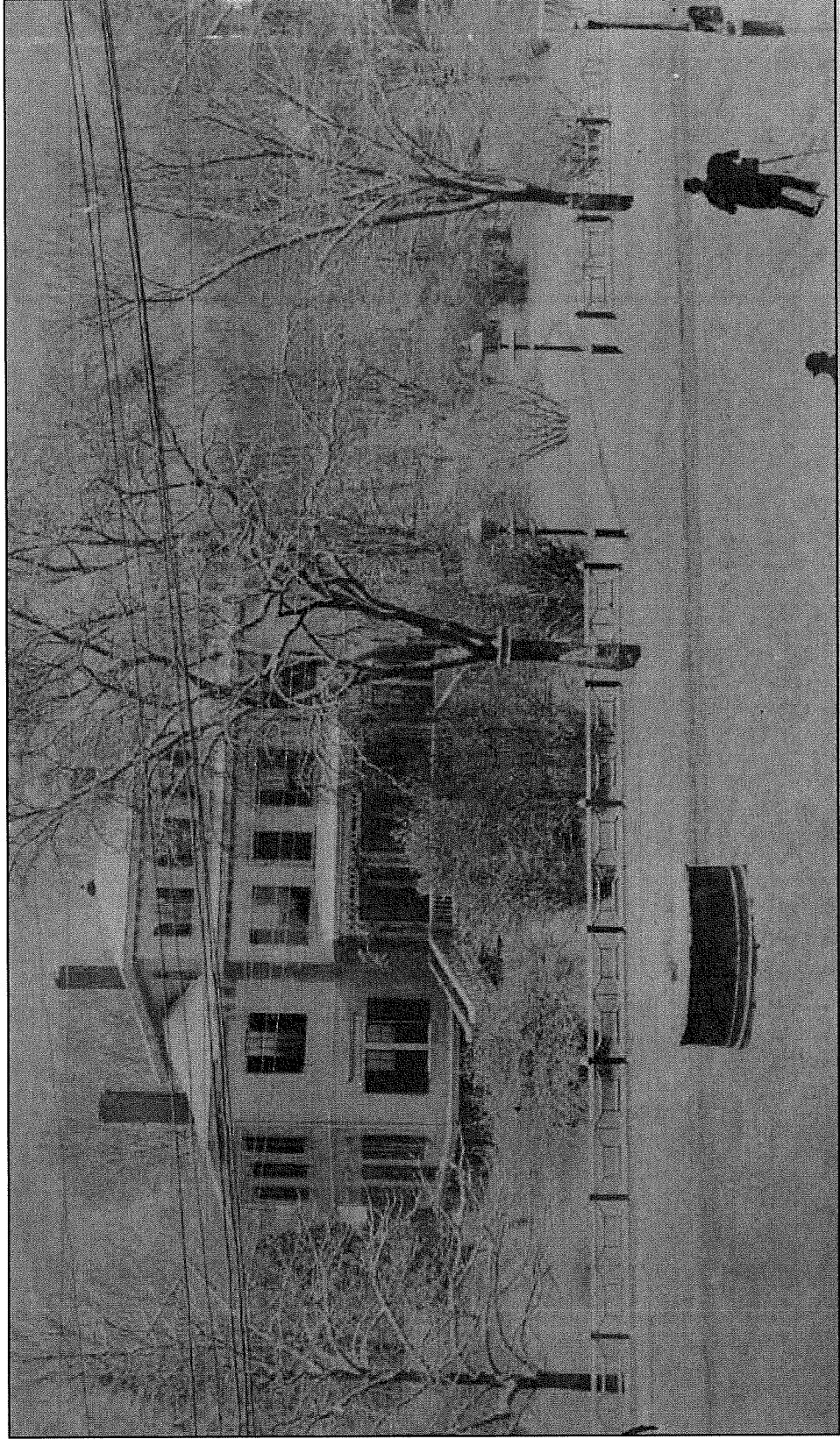

View of 27 Craigie Street circa 1884

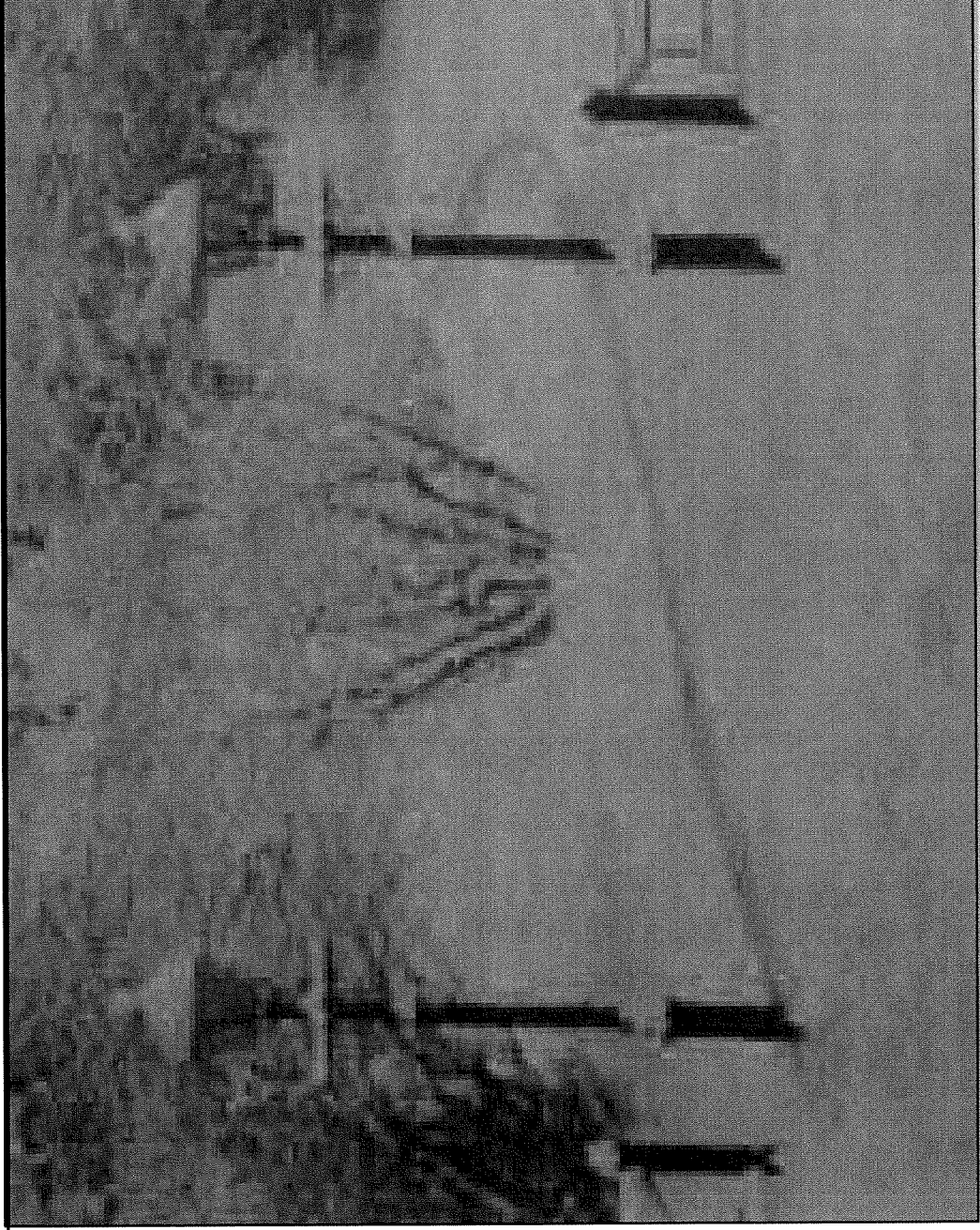

View of Entrance of 27 Craigie Street

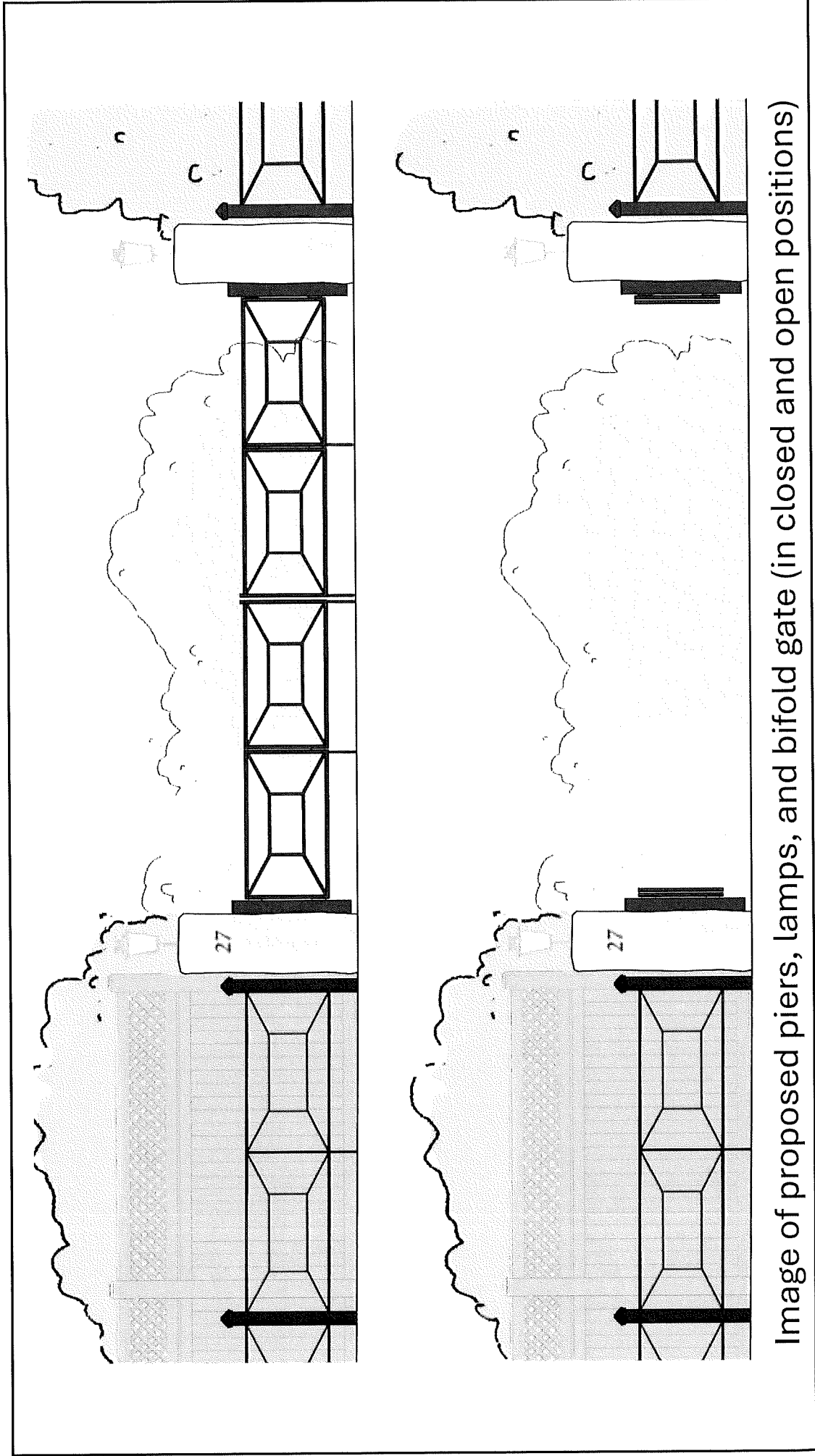
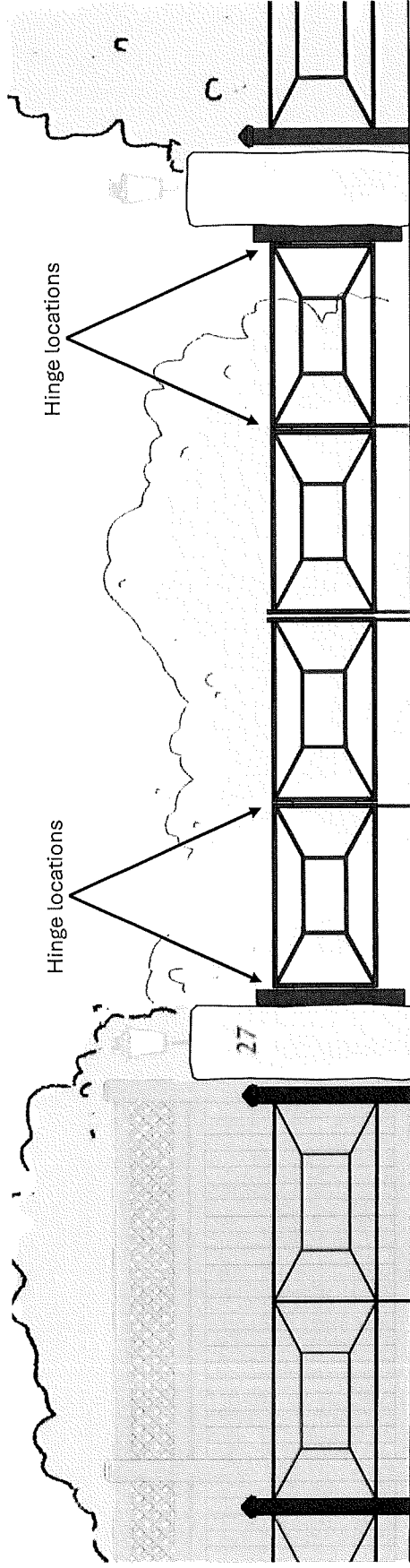
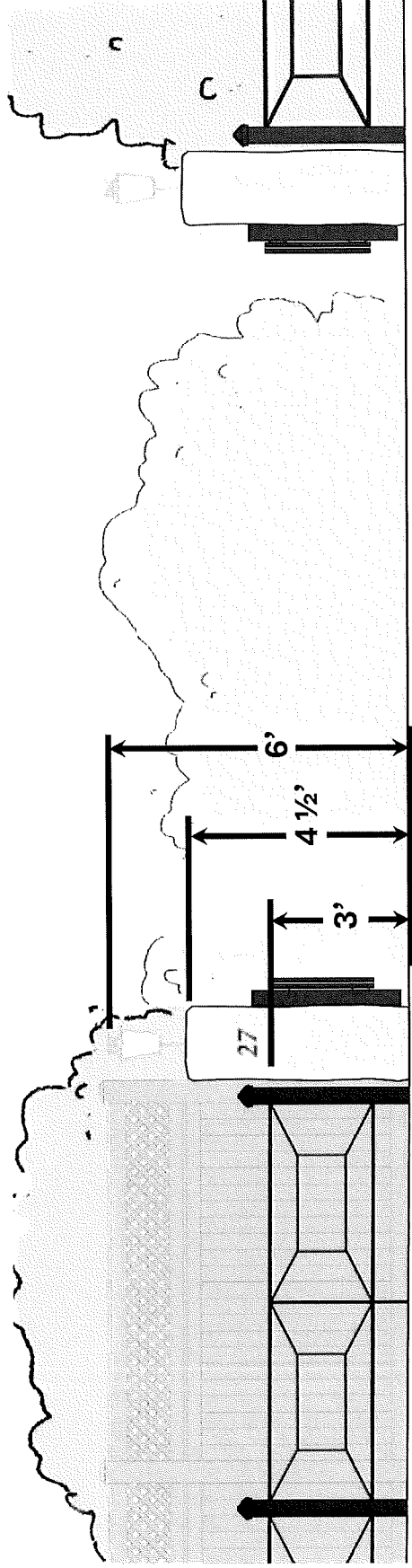

Image of proposed piers, lamps, and bifold gate (in closed and open positions)



Hinge locations of bifold gate



Approximate dimensions (subject to change based on field conditions)

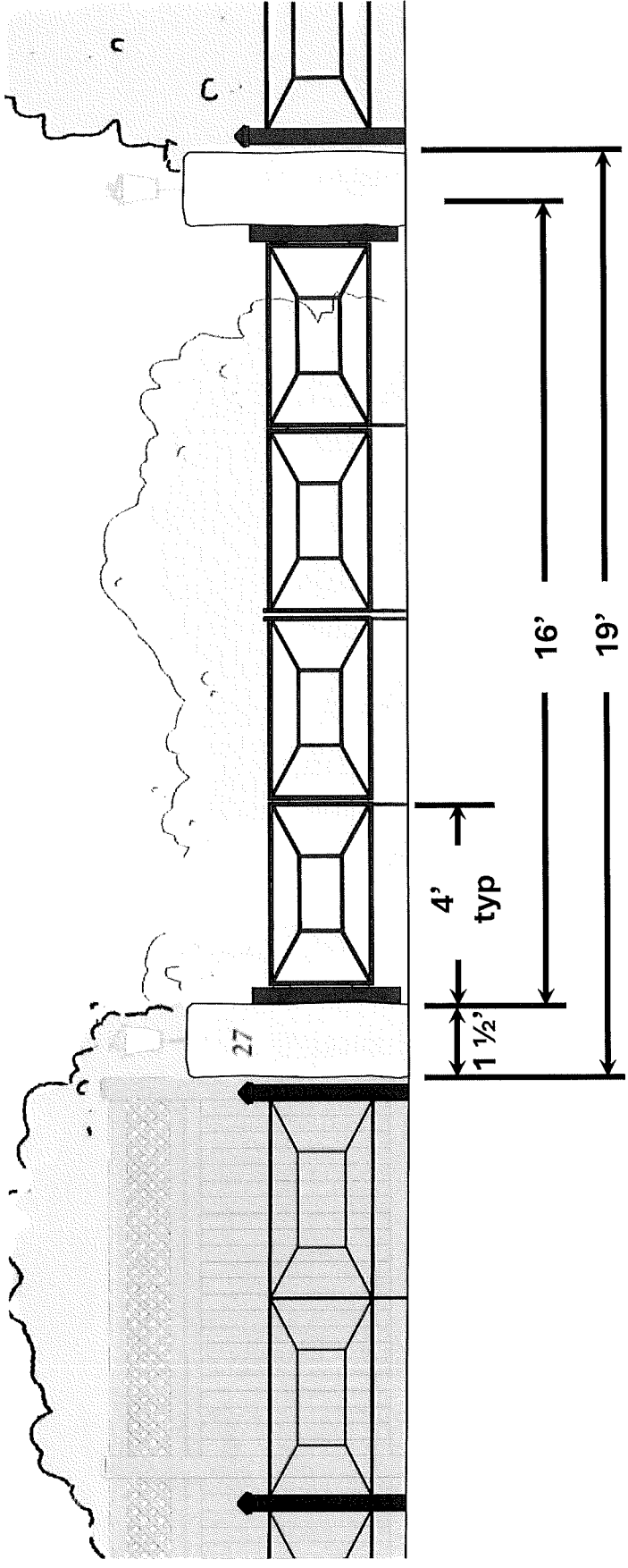

Approximate dimensions (subject to change based on field conditions)

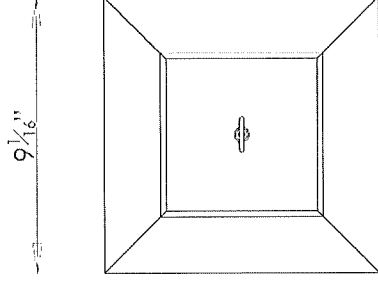
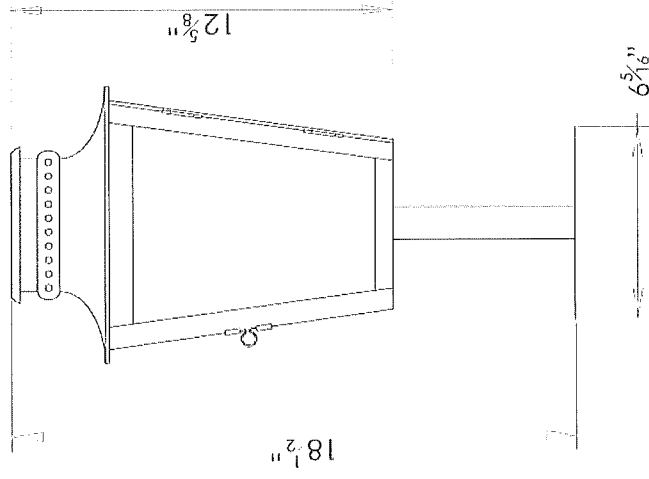
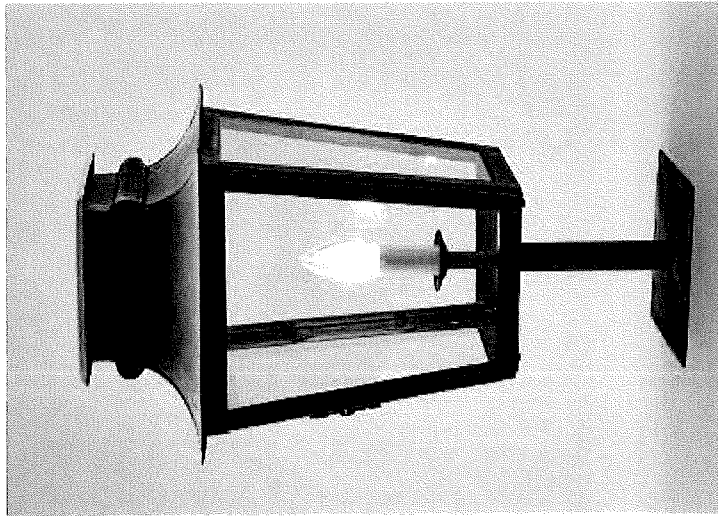

Approximate lamp dimensions

Proposed lamps (subject to change based on availability and final dimensions of piers)

Metal (bronze or black painted metal) house number affixed (not carved) to pier nearest Sparks Street.

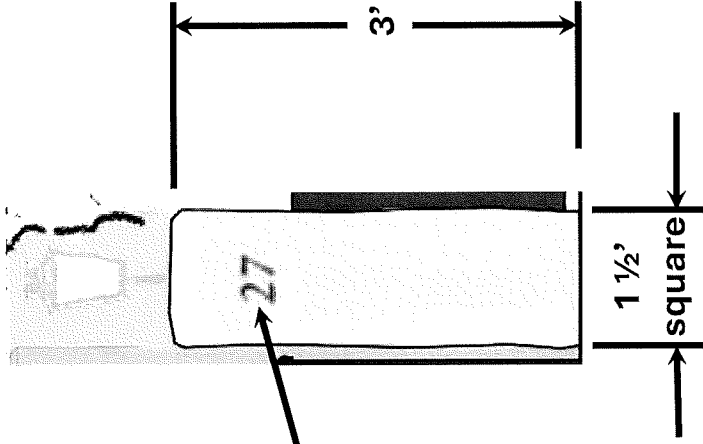

Pier approximate dimensions

Material: Locally-sourced granite

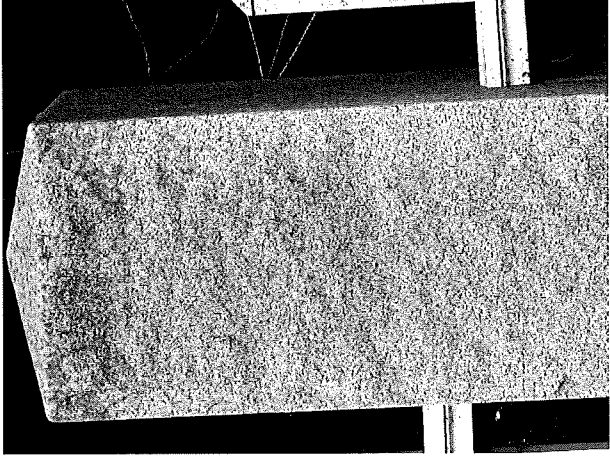

Reference image of approximate surface roughness of proposed piers. Color of final piers subject to change based on availability.

Proposed piers